

ZA312 maratone

PR41
Hearing Aid Battery
Swiss Made



Technical Data Sheet

Specifications

Chemical system	Zinc / Air
Nominal Voltage	1,4 V
Capacity	175 mAh , discharge over 1,500 kΩ 12 hours per day at 20°C to 0,9 V
Self Discharge	Less than 5% per year at 20°C with label applied
Weight	~0,55 g (0.02oz.)

These batteries need air when they are used
Battery compartment must allow free access of air

Dimensions

(according IEC 60086-2)

Diameter	7,83 mm (0,308")
Height	3,50 mm (0,138")

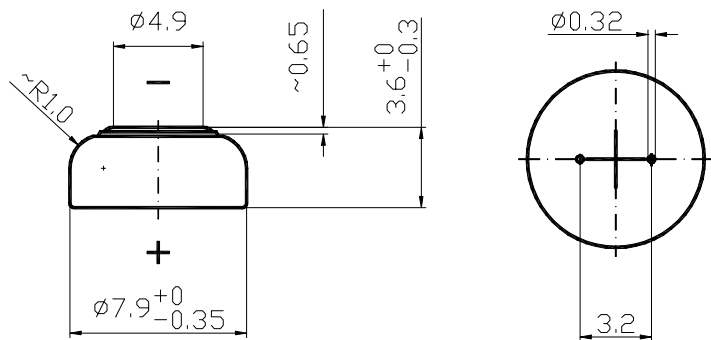

Discharge Curve

Constant Resistance Load
1,500 kΩ

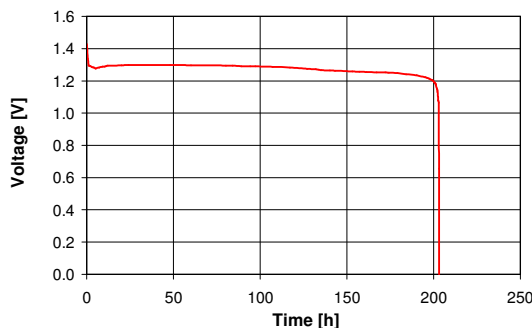

12 hours per day at 20°C, 50% rh
(according IEC 60086-2)

High Power Load
2 mA current, 10 mA pulsed for 100 ms every 2 hours

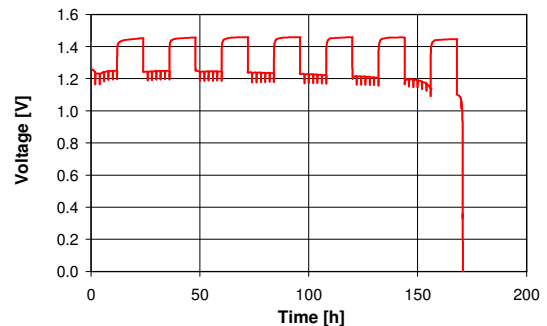

12 hours per day at 20°C, 50% rh
(according IEC 60086-2, 35/1185/CD)

Information and contents in this data sheet are for reference purpose only. They do not constitute any warranty or representation and are subject to change without notice. For most current information and further details, please contact your Renata representative.

Rev. ZA312.14 03/07