

规格书编号

SPEC NO :

# 产 规 书

# SPECIFICATION

CUSTOMER 客 户 : \_\_\_\_\_  
PRODUCT 产 品 : \_\_\_\_\_ SAW FILTER \_\_\_\_\_  
MODEL NO 型 号 : \_\_\_\_\_ HDF476B SMD-4 \_\_\_\_\_  
PREPARED 编 制 : \_\_\_\_\_ CHECKED 审 核 : \_\_\_\_\_  
APPROVED 批 准 : \_\_\_\_\_ D A T E 日 期 : \_\_\_\_\_ 2006-5-11 \_\_\_\_\_

客户确认 CUSTOMER RECEIVED:		
审核 CHECKED	批准 APPROVED	日期 DATE

无锡市好达电子股份有限公司  
Shoulder Electronics Limited



## 更改历史记录

### History Record

更改日期 Date	规格书编号 Spec. No.	产品型号 Part No.	客户产品型号 Customer No.	更改内容描述 Modify Content	备注 Remark

**1. SCOPE**

This specification shall cover the characteristics of SAW filter With F476B used for the page system.

**2. ELECTRICAL SPECIFICATION**

DC Voltage VDC	10V
AC Voltage Vpp	10V50Hz/60Hz
Operation temperature	-20°C to +60°C
Storage temperature	-45°C to +85°C
RF Power Dissipation	0dBm

Electronic Characteristics

2-1. Typical frequency response

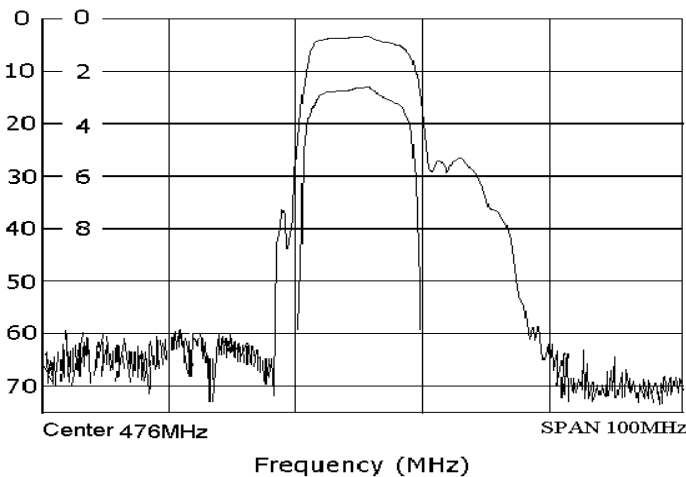

2-2. Electrical characteristics

Part number	F476B	Unit
Nominal center frequency (Fo)	476	MHz
Insertion Loss		
1.fo-25~fo-18 MHz	50min.	dB
2.fo±3.0 MHz	4.0max.	
3.fo +39.8~ fo +45.8MHz	45min.	
Ripple (with Fo ±3.0MHz)	2.0max	dB
Input/Output Impedance(Nominal)	150//0	Ω/pF

**3. TEST CIRCUIT**

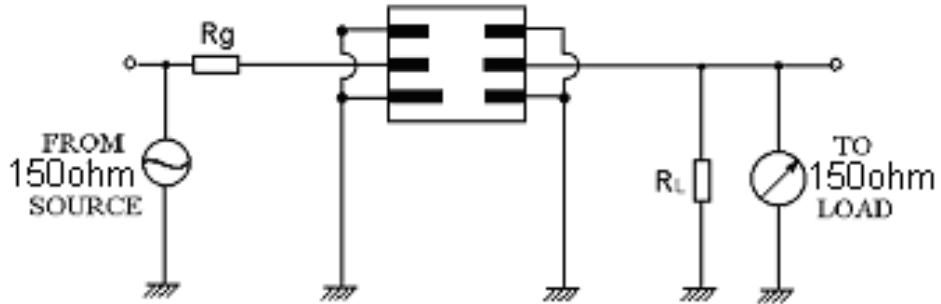

**4. DIMENSION**

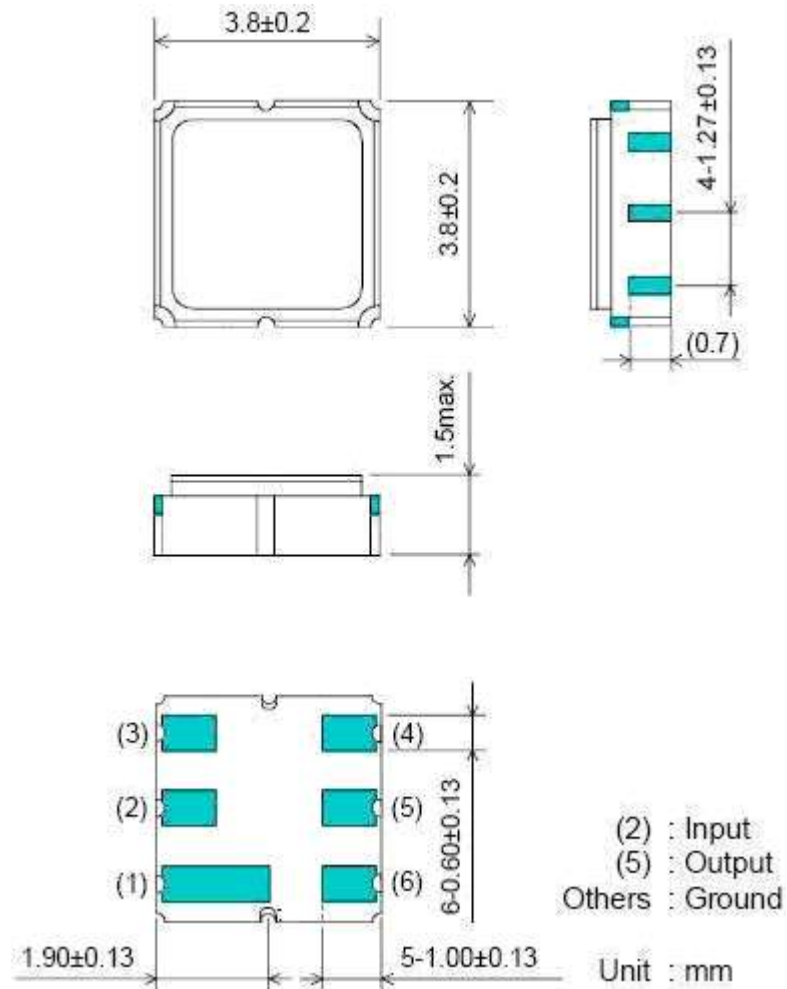

**5. ENVIRONMENTAL CHARACTERISTICS**

5-1 High temperature exposure

Subject the device to +85°C for 16 hours. Then release the filter into the room conditions for 24 hours prior to the measurement. It shall fulfill the specifications in table 1.

#### 5-2 Low temperature exposure

Subject the device to -20°C for 16 hours. Then release the device into the room conditions for 24 hours prior to the measurement. It shall fulfill the specifications in table 1.

#### 5-3 Temperature cycling

Subject the device to a low temperature of -40°C for 30 minutes. Following by a high temperature of +80°C for 30 Minutes. Then release the device into the room conditions for 24 hours prior to the measurement. It shall meet the specifications in table 1.

#### 5-4 Resistance to solder heat

Dip the device terminals no closer than 1.5mm into the solder bath at 260°C ±10°C for 10±1 sec. Then release the device into the room conditions for 4 hours. The device shall meet the specifications in table 1.

#### 5-5 Solderability

Subject the device terminals into the solder bath at 245°C ±5°C for 5s, More than 95% area of the terminals must be covered with new solder. It shall meet the specifications in table 1.

#### 5-6 Mechanical shock

Drop the device randomly onto the concrete floor from the height of 1m 3 times. the device shall fulfill the specifications in table 1.

#### 5-7 Vibration

Subject the device to the vibration for 1 hour each in x,y and z axes with the amplitude of 1.5 mm at 10 to 55 Hz. The device shall fulfill the specifications in table 1.

#### 5-8 Lead fatigue

##### 5-8-1 Pulling test

Weight along with the direction of lead without an shock 1kg. The device shall satisfy all the initial Characteristics.

##### 5-8-2 Bending test

Lead shall be subject to withstand against 90°C bending with 450g weight in the direction of thickness. This operation shall be done toward both direction. The device shall show no evidence of damage and shall satisfy all the initial electrical characteristics.

## 6. REMARK

### 6.1 Static voltage

Static voltage between signal load & ground may cause deterioration & destruction of

the component. Please avoid static voltage.

#### 6.2 Ultrasonic cleaning

Ultrasonic vibration may cause deterioration & destruction of the component. Please avoid ultrasonic cleaning

#### 6.3 Soldering

Only leads of component may be soldered. Please avoid soldering another part of component.

## 7. Packing

### 7.1 Dimensions

- (1) Carrier Tape: Figure 1
- (2) Reel: Figure 2
- (3) The product shall be packed properly not to be damaged during transportation and storage.

### 7.2 Reeling Quantity

- 1000 pcs/reel 7”  
3000 pcs/reel 13”

### 7.3 Taping Structure

- (1) The tape shall be wound around the reel in the direction shown below.

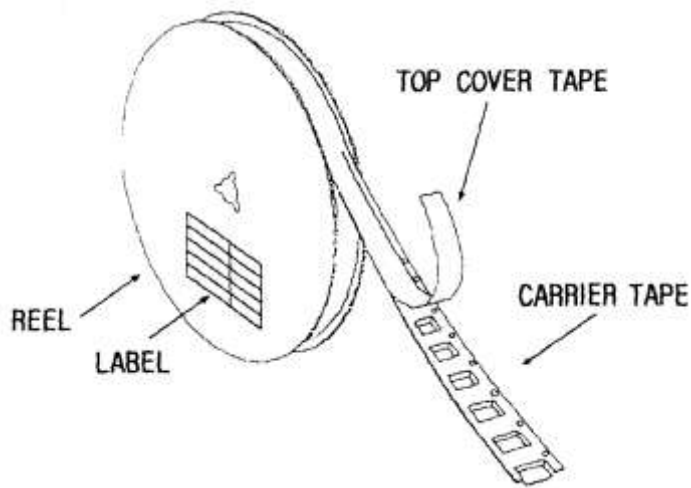

- (2) Label

Device Name	
User Product Name	
Quantity	
Lot No.	

- (3) Leader part and vacant position specifications.



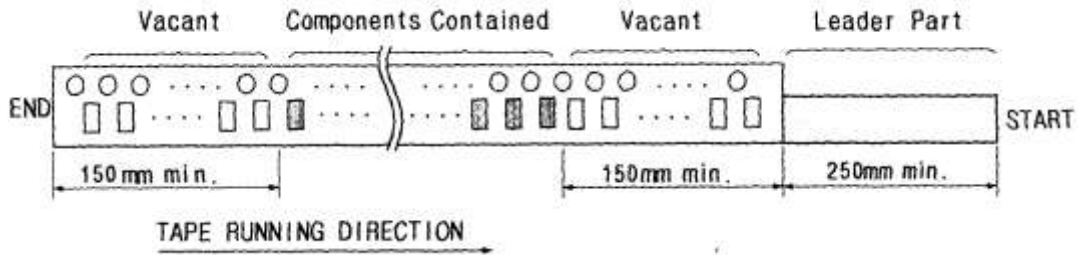

**8. TAPE SPECIFICATIONS**

8.1 Tensile Strength of Carrier Tape: 4.4N/mm width

8.2 Top Cover Tape Adhesion (See the below figure)

- (1) pull off angle: 0~15°
- (2) speed: 300mm/min.
- (3) force: 20~70g

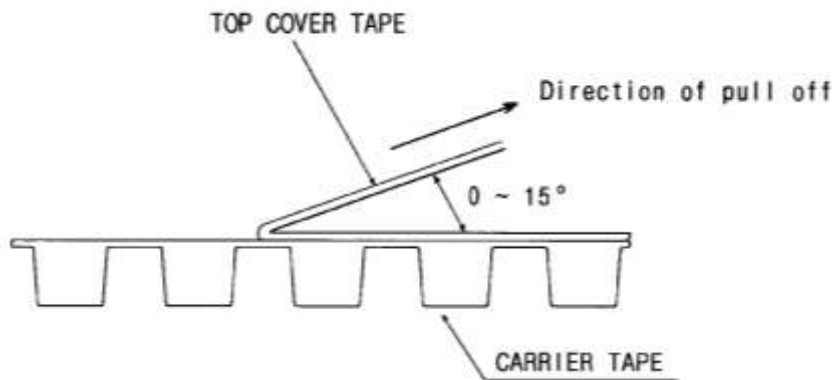

[Figure 1] Carrier Tape Dimensions

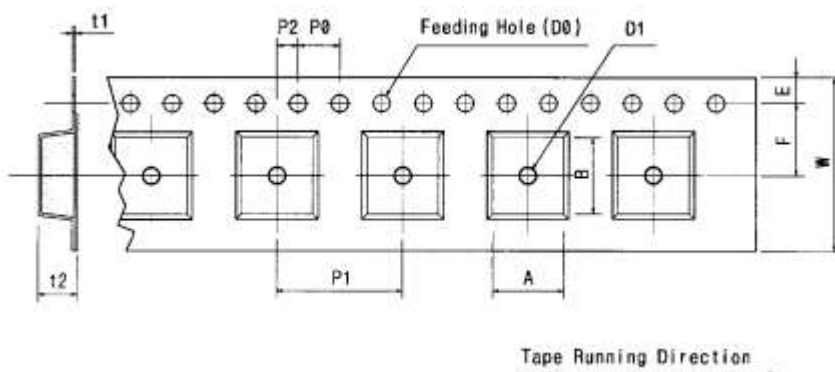

[Unit:mm]

W	F	E	P0	P1	P2	D0	D1	t1	t2	A	B
12.00	5.50	1.75	4.00	8.00	2.00	Ø1.50	Ø1.0	0.25	1.65	4.04	4.10
±0.30	±0.10	±0.10	±0.10	±0.10	±0.10		±0.25	±0.05	±0.10	±0.10	±0.10

[Figure 2]

[Unit:mm]

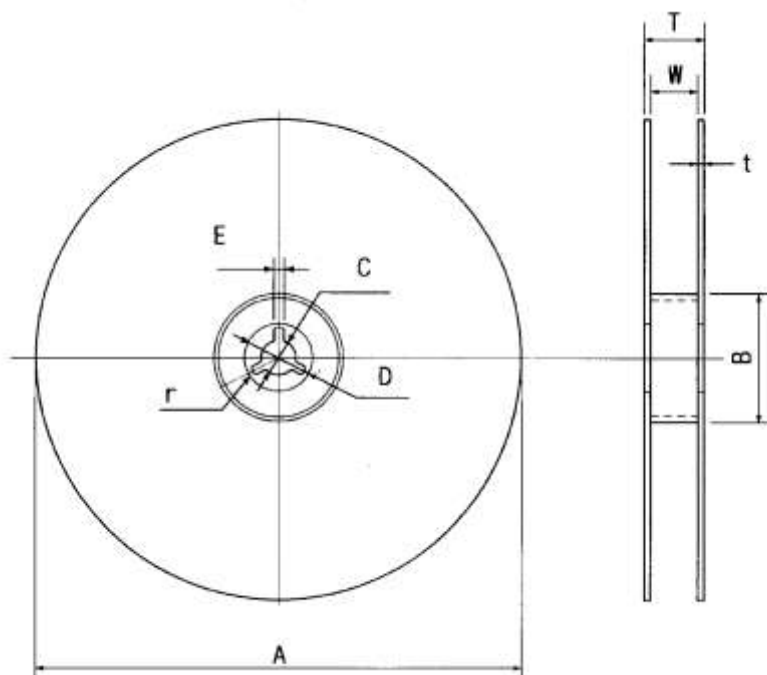

A	B	C	D	E	W	t	r
Ø330	Ø100	Ø13	Ø21	2	13	3	1.0
±1.0	±0.5	±0.5	±0.8	±0.5	±0.3	max.	max.