

规格书编号

**SPEC NO :**

# 产品规格书

# SPECIFICATION

CUSTOMER 客户: \_\_\_\_\_  
PRODUCT 产品: \_\_\_\_\_ CRYSTAL FILTER \_\_\_\_\_  
MODEL NO 型号: \_\_\_\_\_ UM-5-21M20A \_\_\_\_\_  
PREPARED 编制: \_\_\_\_\_ LEO \_\_\_\_\_ CHECKED 审核: \_\_\_\_\_ YORK \_\_\_\_\_  
APPROVED 批准: \_\_\_\_\_ LIUMING \_\_\_\_\_ DATE 日期: \_\_\_\_\_ 2014-02-18 \_\_\_\_\_

客户确认 CUSTOMER RECEIVED:		
审核 CHECKED	批准 APPROVED	日期 DATE

无锡市好达电子有限公司  
Shoulder Electronics Limited

---

更改历史记录

History Record

更改日期 Date	规格书编号 Spec No	产品型号 Part No	客户产品型号 Customer No	更改内容描述 Modify Content	备注 Remark

## SPECIFICATION SHEET

APPLICATION

This Standard Will Apply to The Quartz Crystals.

ELECTRICAL DATA

NO	Speciality	Parameter
01	Holder type	MCF UM-5
02	Mode of Oscillations	Fundamental
03	Center Frequency	21.4MHz
04	Pass bandwidth	±10KHz min (at 3dB)
05	Pass band ripple	0.5dB max
06	Insertion loss	1.5dB max
07	Stop Band width	±25KHz max (at 10dB)
08	Terminating impedance	1800 Ω //1.5pf
09	Operating Tem. Range	-20~+70℃
10	Insulated Resistance	500M Ω (max)(DC100V)
11	Aging per Year	±3ppm

□ MECHANICAL DATA

<p>1. Marking:</p>	<div style="border: 1px solid black; padding: 10px; width: fit-content; margin: auto;"> <p style="text-align: center;">SDE 21M20A</p> </div>
<p>2.Shock Test:</p>	<p>Dropping from 50 cm height,3 times on 30mm-thick- hard wood, After testing, the electrical data follows the requirement.</p>
<p>3.Vibration Test:</p>	<p>30 minutes in each direction 10 to 55 Hz, amplitude 0.75mm, After testing, the electrical data follows the requirement.</p>
<p>4.Terminal strength:</p>	<p>Tensile: Fix main body of crystal. Load 0.9kg pulling force along, terminal axial for 30±5 seconds. The terminal can not he pulled out or broken. Bending: Hang 450g object on lead terminal. Bend 90 degree for 2 to 3 seconds. Return to the former place with the same speed and then do it again oppositely. The down-lead does not become broken and loosed.</p>
<p>5.Sealing:</p>	<p>The crystal unit shall be immersed in alcohol for 5 minutes with 5kg pressure per cm<sup>2</sup> . Taking out, Testing the resistance between down- lead and fundamental. The resistance shall be at least 500M Ω (max) (DC100V).</p>
<p>6.Temperature cycle:</p>	<p>2~3 min -20℃ to +70℃ 30min 30min After cycling three times, there is no distinct damage on the surface. Capacity testing requirement as vibration.</p>

□ MECHANICAL DATA

<p>7.Solderability:</p>	<p>The lead(2to2.5mm from terminal to bottom) is immersed in a <math>230 \pm 5^{\circ}\text{C}</math> Solder bath within <math>2 \pm 0.5</math> seconds. The dipping surface of the lead shall be at least 95% covered with a Continuous new solder coating. Capacity testing requirement as vibration.</p>
<p>8. Resistance to soldering heat:</p>	<p>The(2 to 2.5mm from terminal to bottom) is immersed in a <math>350 \pm 10^{\circ}\text{C}</math> solder bath within <math>3.5 \pm 0.5</math> seconds. After testing, without distinct damage on the surface. Capacity testing requirement as vibration.</p>
<p>9. Resistance to heat:</p>	<p>Resistance to the lowest temperature: Stored at <math>-25 \pm 3^{\circ}\text{C}</math> for 2 hours and then at normal temperature for 2 hours before testing. Capacity testing requirement as vibration. Resistance to the highest temperature: Stored at <math>70 \pm 2^{\circ}\text{C}</math> for 2 hours and then at normal temperature for 2 hours before testing. Capacity testing requirement as vibration.</p>
<p>10. Invariable humidity:</p>	<p>Stored at <math>40 \pm 3^{\circ}\text{C}</math> and <math>\text{RH}93\% \pm 2\%</math> for 48 hours and then at normal condition for 2 hours before testing. Without distinct damage to the surface. Capacity testing requirement as vibration.</p>

Test Circuit

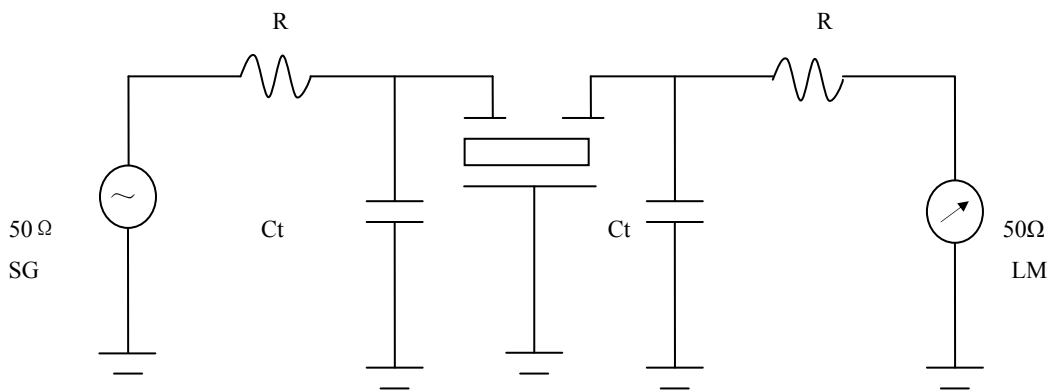

R:  $1750\Omega (\pm 10\%)$ , Ct:  $1.5\text{pf} (\pm 10\%)$ 。

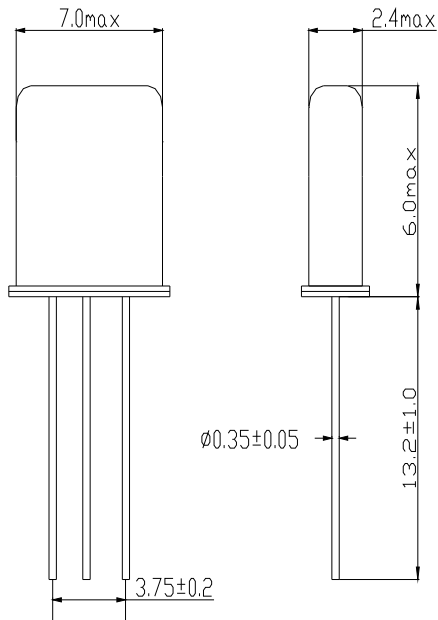
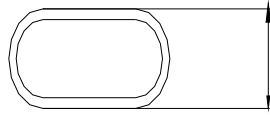

**UM-5**