

规格书编号

SPEC NO :

# 产品规格书

# SPECIFICATION

CUSTOMER 客户: \_\_\_\_\_  
PRODUCT 产品: \_\_\_\_\_ SAW FILTER \_\_\_\_\_  
MODEL NO 型号: \_\_\_\_\_ HDF315A SMD-4 \_\_\_\_\_  
MARKING 印字: \_\_\_\_\_ HDF4304 \_\_\_\_\_  
PREPARED 编制: \_\_\_\_\_ CHECKED 审核: \_\_\_\_\_  
APPROVED 批准: \_\_\_\_\_ D A T E 日期: \_\_\_\_\_ 2006-5-11 \_\_\_\_\_

客户确认 CUSTOMER RECEIVED:		
审核 CHECKED	批准 APPROVED	日期 DATE

无锡市好达电子有限公司  
Shoulder Electronics Limited



## 1. SCOPE

This specification shall cover the characteristics of SAW filter With HDF315A used for the page system.

## 2. ELECTRICAL SPECIFICATION

DC Voltage VDC	10V
AC Voltage Vpp	10V50Hz/60Hz
Operation temperature	-40°C to +85°C
Storage temperature	-45°C to +85°C
RF Power Dissipation	0dBm

### Electronic Characteristics

#### 2-1. Typical frequency response

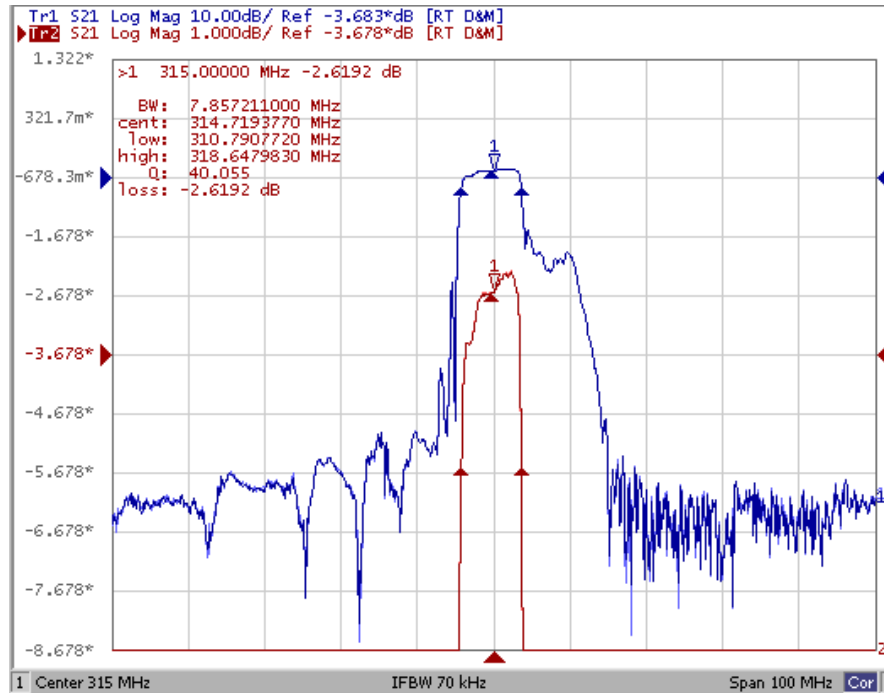

#### 2-2. Electrical characteristics

PART NUMBER	HDF315A	UNIT
NOMINAL CENTERFREQUENCY( $F_0$ )	315.0	MHz
INSERTION LOSS:		
1. $F_0-100\text{MHz TO } -39.5\text{MHz}$	50.0 MIN	dB
2. $F_0\pm 2.0\text{ MHz}$	4.0 MIN	
3. $F_0+39.5\text{ TO } +100\text{MHz}$	50.0 MIN	
RIPPLE (WITH PASSBAND)	2.0 MAX	dB
INPUT AND OUTPUT IMPEDANCE	50/0	$\Omega$ /pF

**3. TEST CIRCUIT**

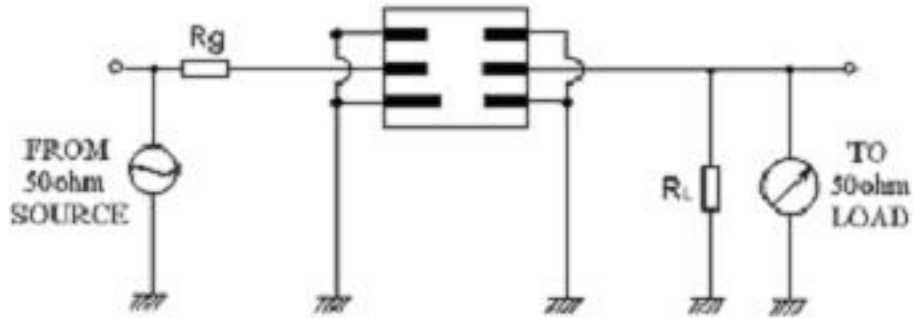

**4. DIMENSION**

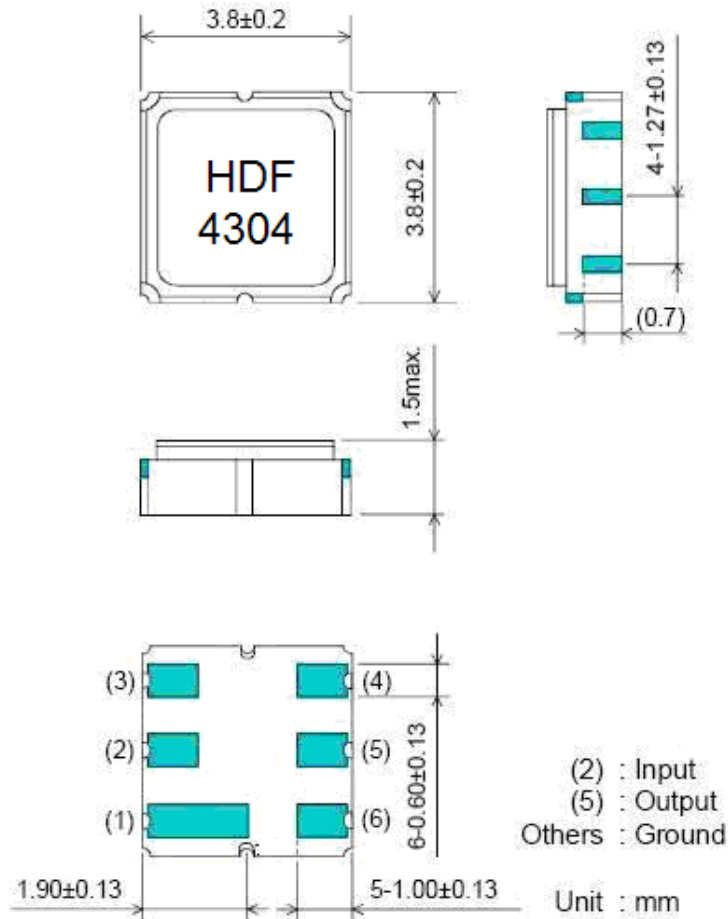

**Marking: HDF4304**

HD: Brand  
 F : Filter  
 4 : SMD-4

304 : No.

## 5. ENVIRONMENTAL CHARACTERISTICS

### 5-1 High temperature exposure

Subject the device to +85°C for 16 hours. Then release the filter into the room conditions for 24 hours prior to the measurement. It shall fulfill the specifications in 2-2.

### 5-2 Low temperature exposure

Subject the device to -40°C for 16 hours. Then release the device into the room conditions for 24 hours prior to the measurement. It shall fulfill the specifications in 2-2.

### 5-3 Temperature cycling

Subject the device to a low temperature of -40°C for 30 minutes. Following by a high temperature of +85°C for 30 Minutes. Then release the device into the room conditions for 24 hours prior to the measurement. It shall meet the specifications in 2-2.

### 5-4 Resistance to solder heat

Dip the device terminals no closer than 1.5mm into the solder bath at 260°C  $\pm$ 10°C for 10 $\pm$ 1 sec. Then release the device into the room conditions for 4 hours. The device shall meet the specifications in 2-2.

### 5-5 Solderability

Subject the device terminals into the solder bath at 245°C  $\pm$ 5°C for 5s, More than 95% area of the terminals must be covered with new solder. It shall meet the specifications in 2-2.

### 5-6 Mechanical shock

Drop the device randomly onto the concrete floor from the height of 1m 3 times. the device shall fulfill the specifications in 2-2.

### 5-7 Vibration

Subject the device to the vibration for 1 hour each in x,y and z axes with the amplitude of 1.5 mm at 10 to 55 Hz. The device shall fulfill the specifications in 2-2.

## 6. REMARK

### 6.1 Static voltage

Static voltage between signal load & ground may cause deterioration & destruction of the component. Please avoid static voltage.

### 6.2 Ultrasonic cleaning

Ultrasonic vibration may cause deterioration & destruction of the component. Please avoid ultrasonic cleaning

### 6.3 Soldering

Only leads of component may be soldered. Please avoid soldering another part of component.

## 7. Packing

### 7.1 Dimensions

- (1) Carrier Tape: Figure 1
- (2) Reel: Figure 2
- (3) The product shall be packed properly not to be damaged during transportation and storage.

### 7.2 Reeling Quantity

- 1000 pcs/reel 7''  
3000 pcs/reel 13''

### 7.3 Taping Structure

- (1) The tape shall be wound around the reel in the direction shown below.

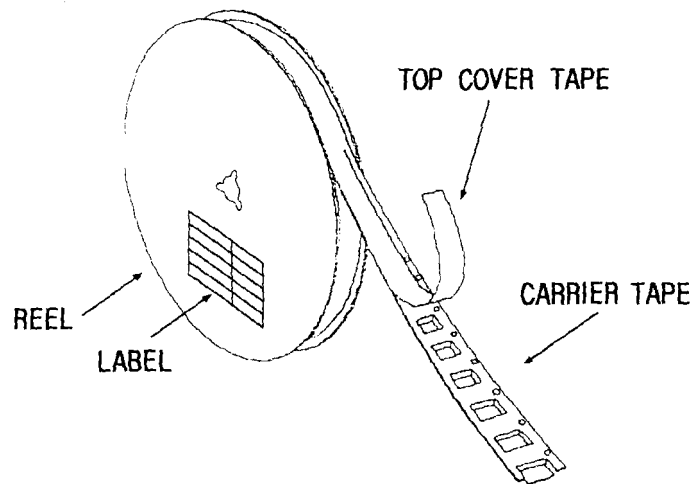

- (2) Label

Device Name	
User Product Name	
Quantity	
Lot No.	

- (3) Leader part and vacant position specifications.

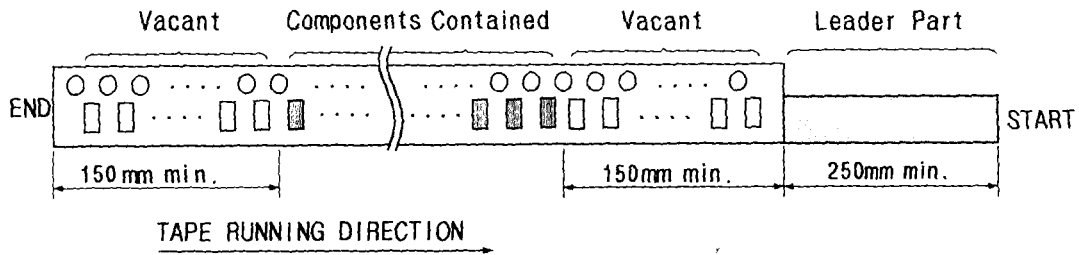

**8. TAPE SPECIFICATIONS**

8.1 Tensile Strength of Carrier Tape: 4.4N/mm width

8.2 Top Cover Tape Adhesion (See the below figure)

- (1) pull off angle: 0~15°
- (2) speed: 300mm/min.
- (3) force: 20~70g

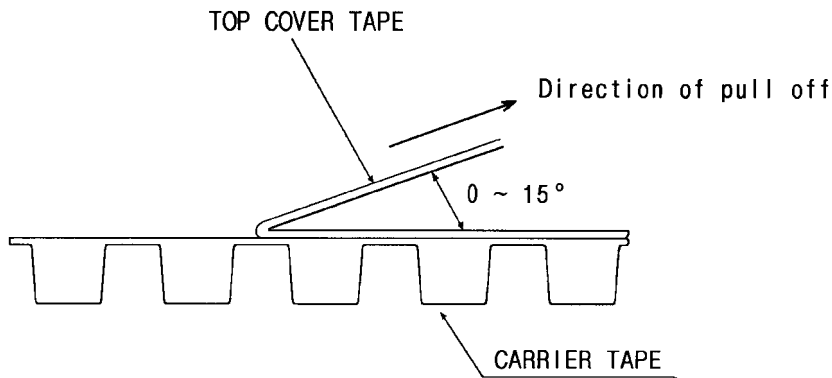

[Figure 1] Carrier Tape Dimensions

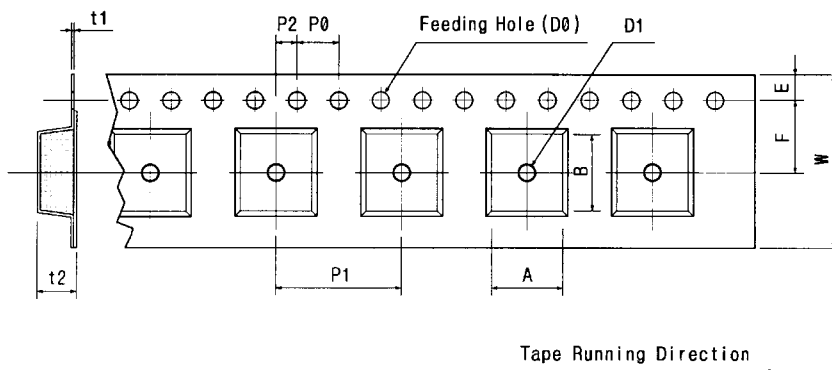

[Unit:mm]

W	F	E	P0	P1	P2	D0	D1	t1	t2	A	B
12.00	5.50	1.75	4.00	8.00	2.00	Ø1.50	Ø1.0	0.25	1.65	4.04	4.10
±0.30	±0.10	±0.10	±0.10	±0.10	±0.10		±0.25	±0.05	±0.10	±0.10	±0.10

[Figure 2]

[Unit:mm]

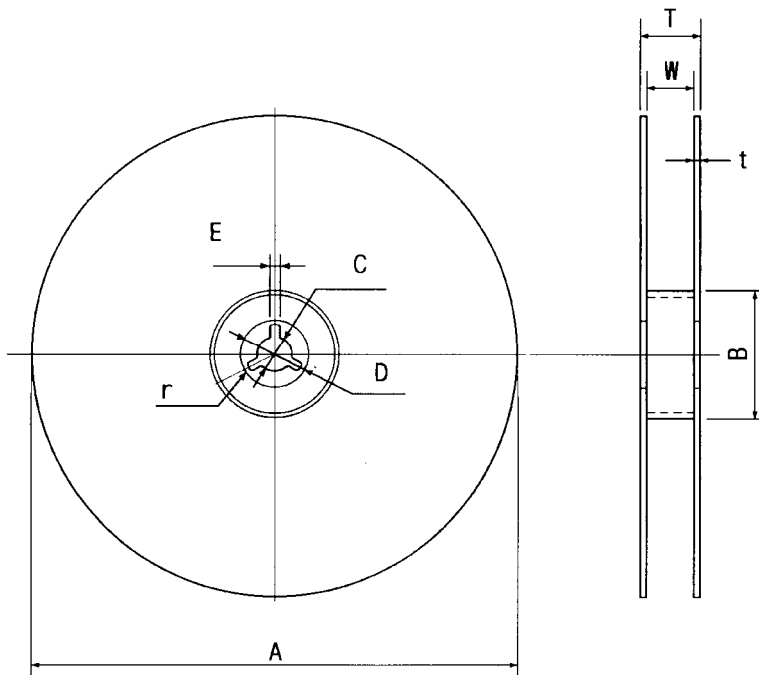

A	B	C	D	E	W	t	r
Ø330	Ø100	Ø13	Ø21	2	13	3	1.0
±1.0	±0.5	±0.5	±0.8	±0.5	±0.3	max.	max.