

规格书编号

SPEC NO :

产品规格书

SPECIFICATION

CUSTOMER 客户: _____

PRODUCT 产品: _____ SAW FILTER _____

MODEL NO 型号: _____ HDF440C SMD-3 _____

MARKING 印字: _____ HDF454 _____

PREPARED 编制: _____ CHECKED 审核: _____

APPROVED 批准: _____ D A T E 日期: _____ 2006-5-11 _____

客户确认 CUSTOMER RECEIVED:		
审核 CHECKED	批准 APPROVED	日期 DATE

无锡市好达电子有限公司
Shoulder Electronics Limited

1. SCOPE

This specification shall cover the characteristics of SAW filter With F440C used for the page system.

2. ELECTRICAL SPECIFICATION

DC Voltage VDC	10V
AC Voltage Vpp	10V50Hz/60Hz
Operation temperature	-40°C to +85°C
Storage temperature	-45°C to +85°C
RF Power Dissipation	0dBm

Electronic Characteristics

2-1. Typical frequency response

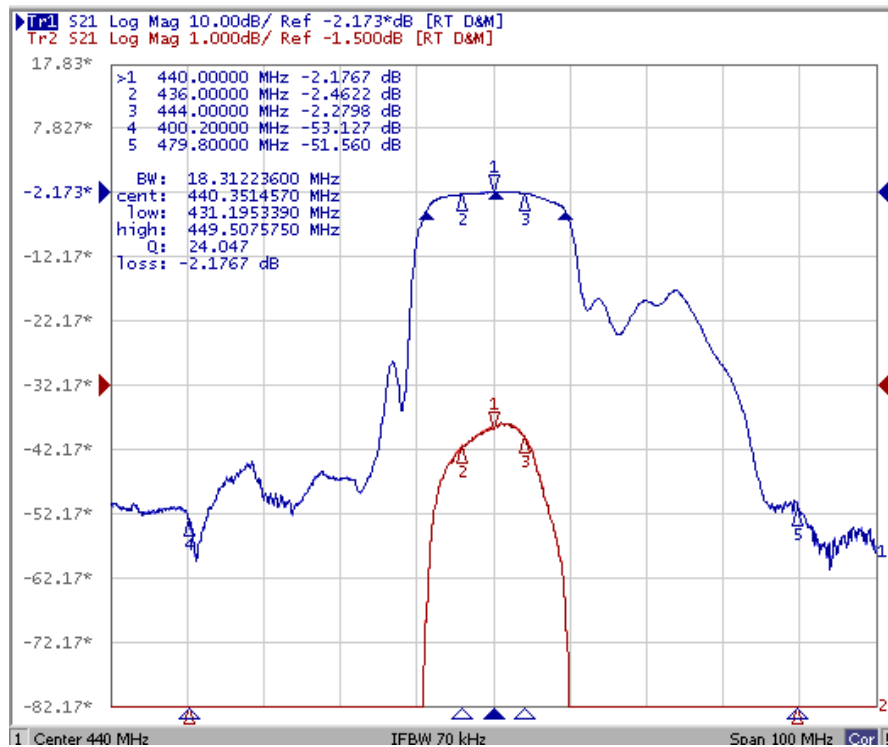

2-2. Electrical characteristics

Part number	HDF440C	
Nominal center frequency (Fo)	439.5	MHz
Insertion Loss		
1. fo-45.8~fo-39.8 MHz	50min.	dB
2. fo ± 4.0 MHz	5.0max.	
3. fo +39.8~ fo +45.8MHz	45min.	
Passband width(-3dB)	18(type)	MHz
Ripple (with Fo ± 3.0MHz)	2.0max	dB
Input/Output Impedance(Nominal)	50//0	Ω/pF

3. TEST CIRCUIT

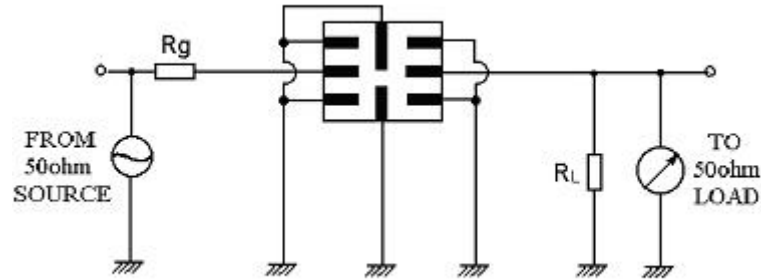

4. DIMENSION

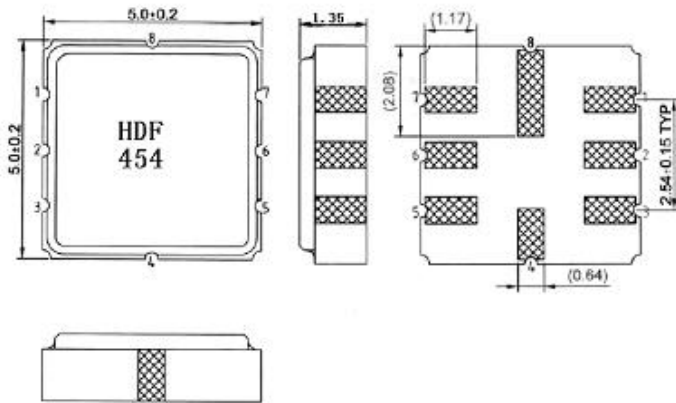

Pin configuration

- 1 Input
- 2 Input Ground
- 5 Output
- 6 Output Ground
- 4, 8 Case – Ground

Marking: HDF454

HD: Brand

F : Filter

454 : No.

5. ENVIRONMENTAL CHARACTERISTICS

5-1 High temperature exposure

Subject the device to +85°C for 16 hours. Then release the filter into the room conditions for 24 hours prior to the measurement. It shall fulfill the specifications in 2-2.

5-2 Low temperature exposure

Subject the device to -40°C for 16 hours. Then release the device into the room conditions for 24 hours prior to the measurement. It shall fulfill the specifications in 2-2.

5-3 Temperature cycling

Subject the device to a low temperature of -40°C for 30 minutes. Following by a high temperature of +85°C for 30 Minutes. Then release the device into the room conditions

for 24 hours prior to the measurement. It shall meet the specifications in 2-2.

5-4 Resistance to solder heat

Dip the device terminals no closer than 1.5mm into the solder bath at $260^{\circ}\text{C} \pm 10^{\circ}\text{C}$ for 10 ± 1 sec. Then release the device into the room conditions for 4 hours. The device shall meet the specifications in 2-2.

5-5 Solderability

Subject the device terminals into the solder bath at $245^{\circ}\text{C} \pm 5^{\circ}\text{C}$ for 5s, More than 95% area of the terminals must be covered with new solder. It shall meet the specifications in 2-2.

5-6 Mechanical shock

Drop the device randomly onto the concrete floor from the height of 1m 3 times. the device shall fulfill the specifications in 2-2.

5-7 Vibration

Subject the device to the vibration for 1 hour each in x,y and z axes with the amplitude of 1.5 mm at 10 to 55 Hz. The device shall fulfill the specifications in 2-2.

6. REMARK

6.1 Static voltage

Static voltage between signal load & ground may cause deterioration & destruction of the component. Please avoid static voltage.

6.2 Ultrasonic cleaning

Ultrasonic vibration may cause deterioration & destruction of the component. Please avoid ultrasonic cleaning

6.3 Soldering

Only leads of component may be soldered. Please avoid soldering another part of component.

7. Packing

7.1 Dimensions

- (1) Carrier Tape: Figure 1
- (2) Reel: Figure 2
- (3) The product shall be packed properly not to be damaged during transportation and storage.

7.2 Reeling Quantity

1000 pcs/reel 7''
3000 pcs/reel 13''

7.3 Taping Structure

- (1) The tape shall be wound around the reel in the direction shown below.

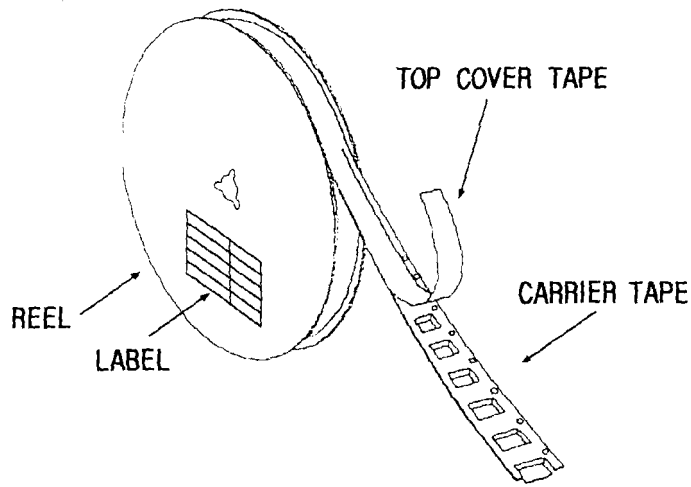

(2) Label

Device Name	
User Product Name	
Quantity	
Lot No.	

(3) Leader part and vacant position specifications.

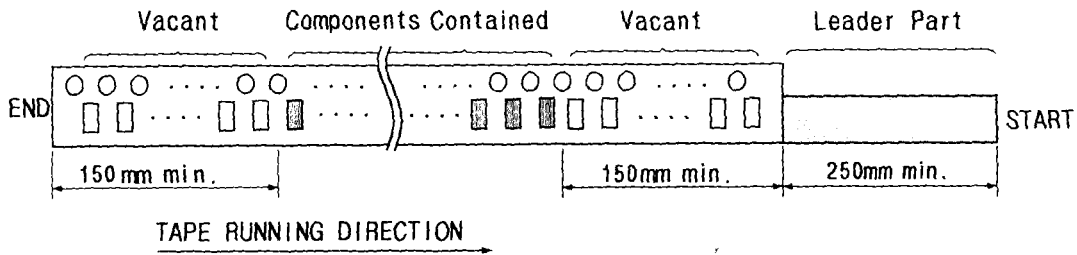

8. TAPE SPECIFICATIONS

8.1 Tensile Strength of Carrier Tape: 4.4N/mm width

8.2 Top Cover Tape Adhesion (See the below figure)

- (1) pull off angle: 0~15°
- (2) speed: 300mm/min.

(3) force: 20~70g

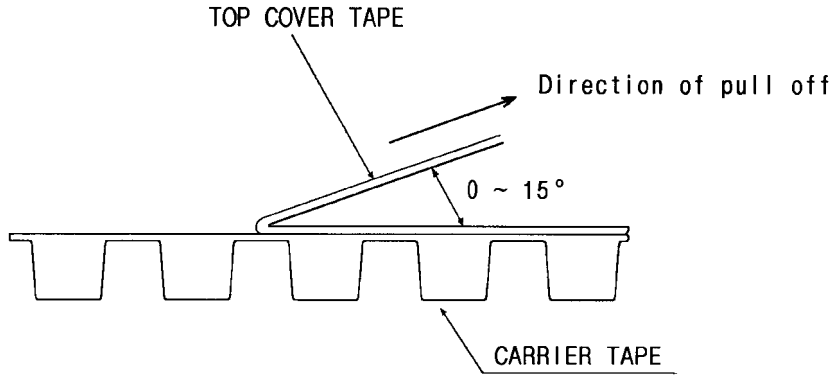

[Figure 1] Carrier Tape Dimensions

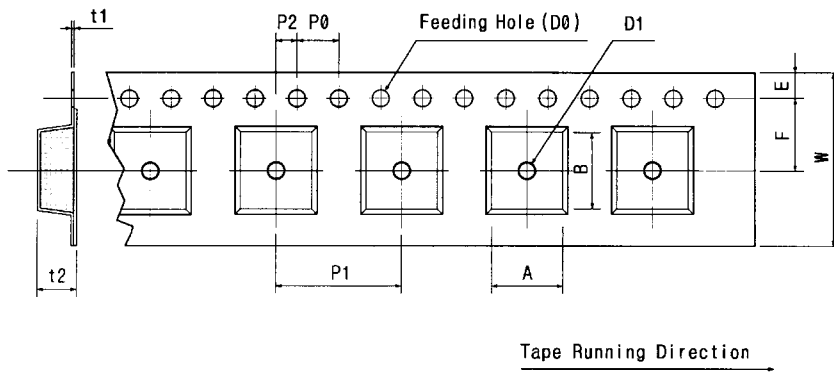

[Unit:mm]

W	F	E	P0	P1	P2	D0	D1	t1	t2	A	B
12.0	5.5	1.75	4.0	8.0	2.0	Ø1.5	Ø1.0	0.3	2.10	6.40	5.20
±0.3	±0.05	±0.1	±0.1	±0.1	±0.05	±0.1	±0.25	±0.05	±0.1	±0.1	±0.1

[Figure 2]

[Unit:mm]

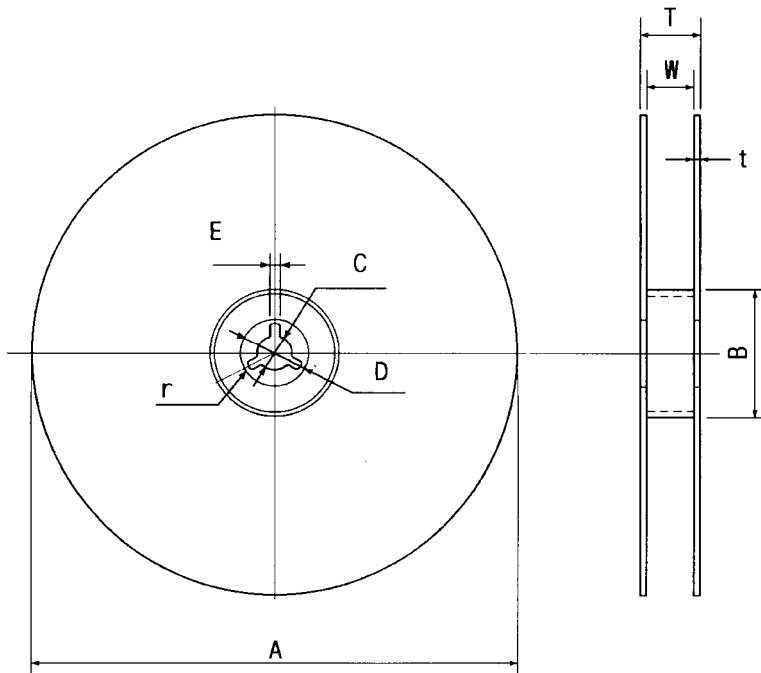

A	B	C	D	E	W	t	r
Ø330	Ø100	Ø13	Ø21	2	13	3	1.0
±1.0	±0.5	±0.5	±0.8	±0.5	±0.3	max.	max.