



SHOULDER

SHOULDER ELECTRONICS LIMITED

SPECIFICATION FOR APPROVAL

NO 编号: 200700191

CUSTOMER 客 户: _____
PRODUCT 产 品: SAW FILTER
MODEL NO 型 号: HDIF389B3M
PREPARED 编 制: Fengyu CHECKED 审 核: York
APPROVED 批 准: Lijiating D A T E 日 期: 2007-02-13

CUSTOMER 客户确认意见:

CHECKED 审 核:

APPROVED 批 准:

D A T E 日 期:

公司地址: 广东深圳市福田区车公庙泰然工业区 303 栋 5 楼西座
West 5/F, 303 Bldg., Che Gong Miao, Industry Park, Futian
Dist., Shenzhen, Guangdong, China.

Tel: 86-755-82916880 Fax: 86-755-82916881

工厂地址: 江苏无锡市滨湖经济技术开发区高运路 115 号

No. 115, Gaoyun road, Binhu Economic&Technology Development
Area, Wuxi, Jiangsu, China

Tel: 86-510-5629111 Fax: 86-510-5627222

[Website: www.shoulder.cn](http://www.shoulder.cn)

1. SCOPE

The SAW filter series have broad line up products meeting all broadcast standard including NTSC, PAL and SECAM systems. These filters are composed of two interdigital transducers on a single-crystal, piezoelectrical chip. They are used in electronic equipments such as TV and so on.

2. Construction

2.1 Dimension and materials

Type: IF389B3M

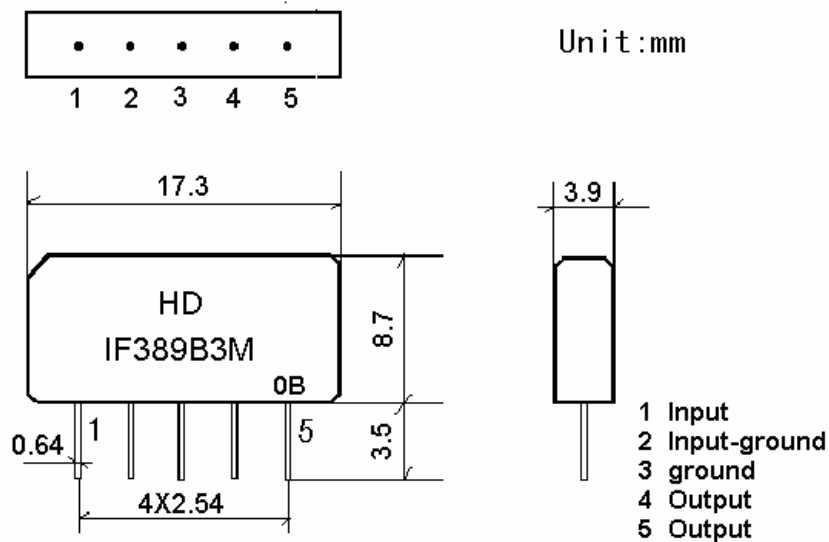

0: year(0,1,2,3,4,5,6,7,8,9)

B:product in this quarter(A:1~3,B:4~6,C:7~9,D:10~12)

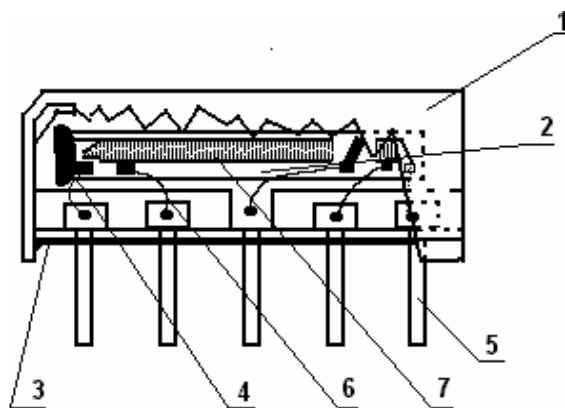

Components	Materials
1.Outer casing	PPS
2.Substrate	Lithium niobate
3.Base	Epoxy resin
4.Absorber	Epoxy resin
5.Lead	Cu alloy+Au plate
6.Bonding wire	AlSi alloy
7.Electrode	Al

2.2. Circuit construction, measurement circuit

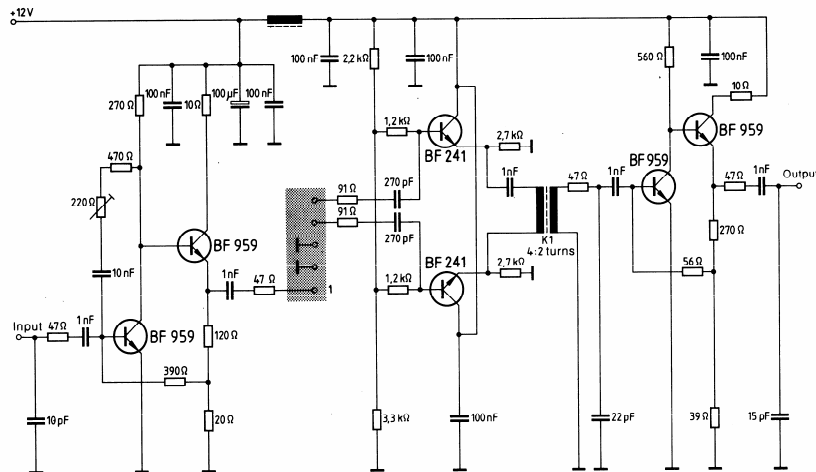

Test circuit for SIP-5 filter
Input impedance of the symmetrical post-amplifier: $2\text{ k}\Omega$ in parallel with 3 pF

3.Characteristics

Standard atmospheric conditions

Unless otherwise specified, the standard range of atmospheric conditions for making measurements and tests is as follows;

- Ambient temperature : 15°C to 35°C
- Relative humidity : 25% to 85%
- Air pressure : 86kPa to 106kPa

Operating temperature rang

Operating temperature rang is the rang of ambient temperatures in which the filter can be operated continuously. $-10^{\circ}\text{C} \sim +60^{\circ}\text{C}$

Storage temperature rang

Storage temperature rang is the rang of ambient temperatures at which the filter can be stored without damage.

Conditions are as specified elsewhere in these specifications. $-40^{\circ}\text{C} \sim +70^{\circ}\text{C}$

Reference temperature $+25^{\circ}\text{C}$

3.1 Maximum Rating

DC voltage	VDC	12	V	Between any terminals
AC voltage	Vpp	10	V	Between any terminals

3.2 Electrical Characteristics

Source impedance

$$Z_S=50\ \Omega$$

Load impedance

$$Z_L=2k\ \Omega // 3pF$$

$$T_A=25^\circ C$$

Items	Freq	Min	typ	max	
Insertion attenuation Reference level	37.40MHz	15.2	17.2	19.2	dB
Relative attenuation	38.90MHz	4.1	5.6	7.1	dB
	34.47MHz	1.6	3.1	4.6	dB
	32.40MHz	18.4	20.4	22.4	dB
	33.40MHz	17.3	19.3	-	dB
	30.90MHz	43.0	57.0		dB
	31.90MHz	38.0	48.0		dB
	40.40MHz	42.0	55.0		dB
Sidelobe	25.00~30.90MHz	38.0	47.0		dB
	40.40~45.00MHz	35.0	43.0		dB
Reflected wave signal suppression 1.2 μ s...6.0 μ s after main pulse (test pulse 250ns, carrier frequency 37.4MHz)		40.0	50.0		dB
Feedthrough signal suppression 1.2 μ s...1.1 μ s before main pulse (test pulse 250ns, carrier frequency 37.4MHz)		42.0	52.0	-	dB
Group delay predistortion (reference frequency 38.90 MHz)					
36.90 MHz		-	-55	-	ns
34.47 MHz		-	45	-	ns
Impedance at 37.40 MHz: Input: $Z_{in} = R_{in} // C_{in}$ Output $Z_{out}=R_{out} // C_{out}$		-	2.2//11.9 3.8 //2.8	-	k Ω //pF k Ω //pF
Temperature coefficient			-72		Ppm/k

3.3 Environmental Performance Characteristics

Item Test condition	Allowable change of absolute Level at center frequency (dB)
High temperature test 70°C 1000H	< 1.0
Low temperature test -40°C 1000H	< 1.0
Humidity test 40°C 90-95% 1000H	< 1.0
Thermal shock -20°C==25°C==80°C 20 cycle 30M 10M 30M	< 1.0
Solder temperature test Sold temp.260°C for 10 sec.	< 1.0

Soldering Immerse the pins melt solder at 260°C+5/-0°C for 5 sec.	More then 95% of total area of the pins should be covered with solder
---	---

3.4 Mechanical Test

Item Test condition	Allowable change of absolute Level at center frequency(dB)
Vibration test 600-3300rpm amplitude 1.5mm 3 directions 2 H each	<1.0
Drop test On maple plate from 1 m high 3 times	<1.0
Lead pull test Pull with 1 kg force for 30 seconds	<1.0
Lead bend test 90° bending with 500g weigh 2 times	<1.0

3.5 Voltage Discharge Test

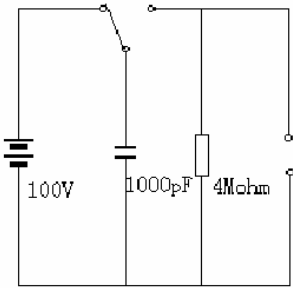
Item Test condition	Allowable change of absolute Level at center frequency (dB)
Surge test Between any two electrode 	<1.0