

规格书编号

SPEC NO :

产品规格书

SPECIFICATION

CUSTOMER 客户: _____
PRODUCT 产品: _____ SAW RESONATOR
MODEL NO 型号: _____ HDR310D-TO39
PREPARED 编制: _____ CHECKED 审核: _____
APPROVED 批准: _____ DATE 日期: _____ 2016-07-18

客户确认 CUSTOMER RECEIVED:		
审核 CHECKED	批准 APPROVED	日期 DATE

无锡市好达电子有限公司
Shoulder Electronics Limited

1. SCOPE

This specification is applied to a SAW resonator designed for the stabilization of transmitters such as garage door openers and security transmitters.

2. ELECTRICAL SPECIFICATION

DC Voltage VDC	10V
AC Voltage Vpp	10V50Hz/60Hz
Operation temperature	-40°C to +85°C
Storage temperature	-45°C to +85°C
RF Power Dissipation	0dBm

Electronic Characteristics

Item	Unites	Min	Typ	Max
Center Frequency	MHz	309.900	310.000	310.100
Insertion Loss	dB		6.0	8.0
Quality Factor	Unload Q	8000	12000	
	50Ω Loaded Q	5000	6300	
Temperature Stability	Turnover Temperature	°C	10	25
	Freq.temp.Coefficient	ppm/°C		0.032
Frequency Aging	ppm/yr		<±10	
DC. Insulation Resistance	MΩ	1.0		

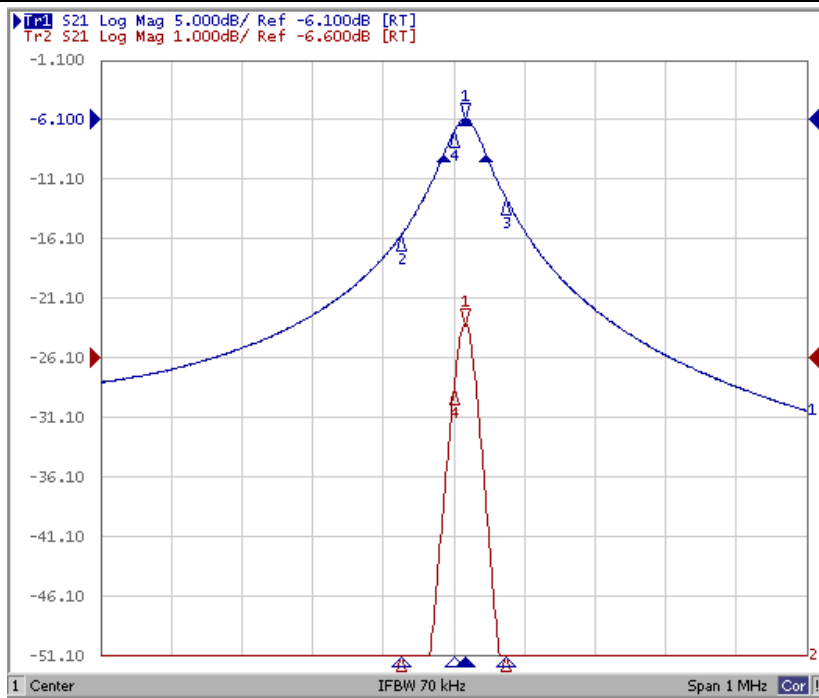

3. TEST CIRCUIT

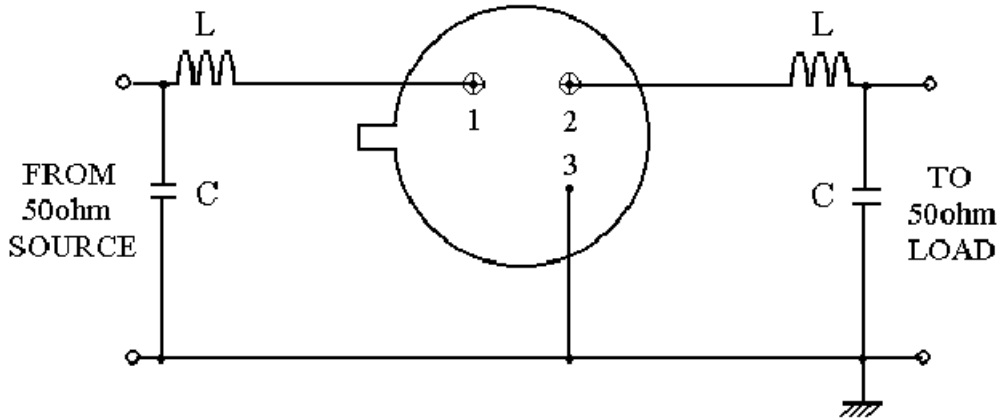

4. DIMENSION

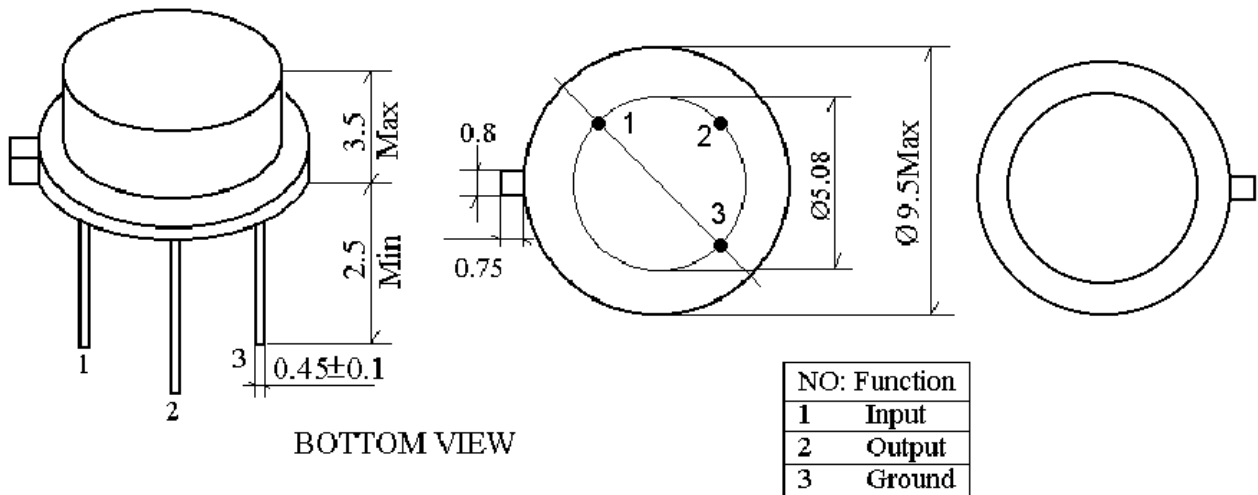

5. ENVIRONMENTAL CHARACTERISTICS

5-1 High temperature exposure

Subject the device to +85°C for 16 hours. Then release the filter into the room conditions for 24 hours prior to the measurement. It shall fulfill the specifications in table 1.

5-2 Low temperature exposure

Subject the device to -20°C for 16 hours. Then release the device into the room conditions for 24 hours prior to the measurement. It shall fulfill the specifications in table 1.

5-3 Temperature cycling

Subject the device to a low temperature of -40°C for 30 minutes. Following by a high temperature of +80°C for 30 Minutes. Then release the device into the room conditions for 24 hours prior to the measurement. It shall meet the specifications in table 1.

5-4 Resistance to solder heat

Dip the device terminals no closer than 1.5mm into the solder bath at 260°C ±10°C for 10 ± 1 sec. Then release the device into the room conditions for 4 hours. The device shall

meet the specifications in table 1.

5-5 Solderability

Subject the device terminals into the solder bath at $245^{\circ}\text{C} \pm 5^{\circ}\text{C}$ for 5s, More than 95% area of the terminals must be covered with new solder. It shall meet the specifications in table 1.

5-6 Mechanical shock

Drop the device randomly onto the concrete floor from the height of 1m 3 times. the device shall fulfill the specifications in table 1.

5-7 Vibration

Subject the device to the vibration for 1 hour each in x,y and z axes with the amplitude of 1.5 mm at 10 to 55 Hz. The device shall fulfill the specifications in table 1.

5-8 Lead fatigue

5-8-1 Pulling test

Weight along with the direction of lead without an shock 1kg. The device shall satisfy all the initial Characteristics.

5-8-2 Bending test

Lead shall be subject to withstand against 90°C bending with 450g weight in the direction of thickness. This operation shall be done toward both direction. The device shall show no evidence of damage and shall satisfy all the initial electrical characteristics.

6. REMARK

6.1 Static voltage

Static voltage between signal load & ground may cause deterioration & destruction of the component. Please avoid static voltage.

6.2 Ultrasonic cleaning

Ultrasonic vibration may cause deterioration & destruction of the component. Please avoid ultrasonic cleaning

6.3 Soldering

Only leads of component may be soldered. Please avoid soldering another part of component.