

Specification for Transducer	Page	2/12
Model No. : KPT-G1420A-3542	Revision No.	1.0
	Drawing No.	OEM3542R

CONTENTS

1. Scope
范围
2. General
概要
3. Maximum Rating
额定极限条件
4. Electrical Characteristics
电性能
5. Measuring Method
测试方法
6. Physical Characteristics
机械性能
7. Environmental Characteristics
环境性能
8. Dimensions
尺寸
9. Packaging Standard
包装标准
10. Cautions
警告
11. Cautions for Use
注意事项
12. Revision
履历表

Specification for Transducer	Page	3/12
	Revision No.	1.0
	Drawing No.	OEM3542R
Model No. : KPT-G1420A-3542		

1. 范围 Scope

This product specification is applied to the piezoelectric sounder in alarm systems. Please contact us when using this product for any other applications than described in the above.

本规格书适用于压电式蜂鸣器，通常它用在系统中做报警或提示的蜂鸣器用，如果将该产品用于其它领域，请与我们联系。

2. 概要 General

2.1 Out-Diameter : Ø14.2mm

外径: Ø14.2mm

2.2 Height : 11mm

高度: 11mm

2.3 Weight : 2gr.

重量: 2克

2.4 Case Material/Color : PC/Black

壳体材质/颜色: PC/黑

3. 额定极限条件 Maximum Rating

	项目 Item	规格 Specification
3.1	最高输入电压 Maximum input Voltage	30Vp-p Square Wave
3.2	工作温度范围 Operating Temperature Range	-10 ~ +70°C
3.3	储存温度范围 Storage Temperature Range	-20 ~ +80°C

Specification for Transducer Model No. : KPT-G1420A-3542	Page	4/12
	Revision No.	1.0
	Drawing No.	OEM3542R

4. 电性能 Electrical Characteristics

	项目 Item	规格 Specification
4.1	声压 Sound Pressure Level	70dB at 5Vp-p/2.0KHz/10cm
4.2	容量 Capacitance at 100Hz	15000pF± 30%

测试条件参见下项

Refer to next item for measuring method.

5. 测试方法 Measuring Method

5.1 声压测试线路 S.P.L. Measuring Circuit

输入信号:5Vp-p,2.0KHz,方波

Input Signal:5Vp-p,2.0KHZ,Square wave

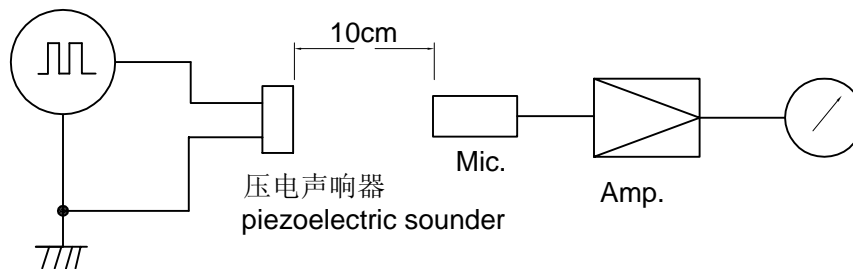

MIC : ND10 普通声级计或等同品

MIC : ND10 Sound Meter or equivalent

S.G. : DF1010 振荡器或等同品

S.G. : DF1010 Oscillater or equivalent

5.2 测试环境 Measuring Condition

温度 $+25\pm 3^{\circ}\text{C}$, 湿度 $60\pm 10\%\text{R.H.}$ 标准测试状态,在没有疑问的场合,可以在温度 $+5\sim +35^{\circ}\text{C}$,湿度 $45\sim 85\%\text{R.H.}$ 的范围内测试.

Part shall be measured under a condition (Temperature : $+5$ to $+35^{\circ}\text{C}$,Humidity :45 to $85\%\text{R.H.}$)unless the standard condition (Temperature : $+25\pm 3^{\circ}\text{C}$,Humidity : $60\pm 10\%\text{R.H.}$) is regulated measure.

Specification for Transducer Model No. : KPT-G1420A-3542	Page	5/12
	Revision No.	1.0
	Drawing No.	OEM3542R

6. 机械性能 Physical Characteristics

	实验项目 Item	实验条件 Test Condition	实验后规格 Specification
6.1	耐冲击性 Shock	100G沿坐标轴之XYZ每方向各2小时试验,然后在常温中放置4小时后,测试声响器. 100G along XYZ each directions of the coordinate for 2 hours testing,finally being placed in natural condition for 4hours,then test the sound.	符合表1的要求 The measured value shall meet Table 1.
6.2	耐振动性 Vibration Resistant	10~55~10Hz,总振幅1.52mm,1分钟/周期,XYZ 方向各2小时试验,然后在常温中放置4小时后,测试声响器. 10~55~10Hz,total vibration of amplitude of 1.5mm, 1min/cycle,test to XYZ each direction for 2hours,finally being placed in natural condition for 4hours,then test the sound.	
6.3	耐焊接性 Soldering Heat Resistance	先将声响器的插针浸入松香液5秒钟,然后插入(插至距声响器壳体1.5mm处为止) +350±5℃的焊锡槽3±0.5秒,然后在常温中放置4小时后,测试声响器. Lead terminals are immersed in rosin for 5 seconds and Lead terminal are immersed up to 1.5mm from sounder's body in solder bath of +350±5℃ for 3±0.5 seconds, and then sounder shall be measured after being placed in natural condition for 4 hours.	
6.4	可焊性 Solderability	先将声响器的插针浸入松香液5秒钟,然后浸入+245±5℃熔融的锡槽中5±0.5秒. Lead terminals are immersed in rosin for 5 seconds and then immersed in solder bath of +245±5℃ for 5±0.5 seconds.	
6.5	跌落试验 Dropping test	从75cm高度自由跌落2回 free fall from 75cm with 2 times.	

Specification for Transducer Model No. : KPT-G1420A-3542	Page	6/12
	Revision No.	1.0
	Drawing No.	OEM3542R

7. 环境性能 Environmental Characteristics

实验项目 Item	实验条件 Test Condition	实验后规格 Specification
7.1 高温放置 Dry Heat Test (Storage)	放置于温度 $+85 \pm 2^\circ\text{C}$ 的烘箱内240小时, 然后取出, 在常温下放置4小时后, 测试声响应器。 After being placed in a chamber with $+85 \pm 2^\circ\text{C}$ for 240 hours and then being placed in natural condition for 4 hours, sounder shall be measured.	符合表1的要求 The measured value shall meet Table 1.
7.2 低温放置 Cold Test (Storage)	放置于温度 $-40 \pm 2^\circ\text{C}$ 的制冷箱内240小时, 然后取出, 在常温下放置4小时后, 测试声响应器。 After being placed in a chamber with $-40 \pm 2^\circ\text{C}$ for 240 hours and then being placed in natural condition for 4 hours, sounder shall be measured.	
7.3 耐湿性 Humidity Test	放置于 90%~95% R.H., 温度 $+60 \pm 2^\circ\text{C}$ 的环境试验箱内240小时, 然后取出, 在常温下放置4小时后, 测试声响应器。 After being placed in a chamber with 90 to 95%R.H. at $+60 \pm 2^\circ\text{C}$ for 240 hours and then being placed in natural condition for 4 hours, sounder shall be measured.	
7.4 热冲击试验 Thermal Shock Test	先放置于温度 $-20 \pm 2^\circ\text{C}$ 的制冷箱内1小时, 然后放置于 $+85 \pm 2^\circ\text{C}$ 的烘箱内1小时, 经过以上循环10次, 在常温下放置4小时后, 测试声响应器。 After being placed in a chamber at $-20 \pm 2^\circ\text{C}$ for 1Hour, sounder shall be placed in a chamber at $+85 \pm 2^\circ\text{C}$. After 1 Hour at this temperature. After 10 above cycles, sounder shall be measured after being placed in natural condition for 4 hours.	
7.5 连续工作试验 Run Continuously Test	20Vp-p, 2.0KHz, 方波条件下, 连续工作240小时, 再在常温下放置4小时后, 测试声响应器。 20Vp-p Square wave, 2.0KHz/240hours, and then sounder shall be measured after being placed in natural condition for 4 hours.	

表 1 Table 1

项 目 Item	试验后变化量 Specification after test
声压级 Sound Pressure Level	初始值 $\pm 10\text{dB}$ Initial Value $\pm 10\text{dB}$

Specification for Transducer Model No. :KPT-G1420A-3542	Page	7/12
	Revision No.	1.0
	Drawing No.	OEM3542R

8. Dimensions

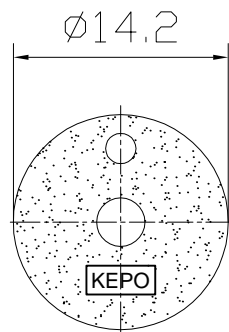
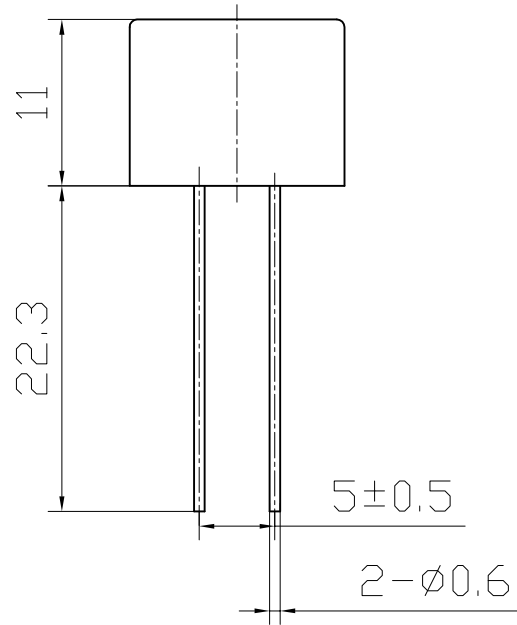

内部构造图
Inner structure

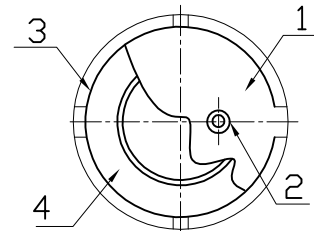

FIRST ANGLE PROJECTION



UNIT : mm
Tolerance : ±0.5

4	Piezp-Element 蜂鸣片	1	Alloy	
			Piezo Ceramic	
3	Case 壳体	1	PC	
2	Pin 插针	2	H62	
1	PCB 印制板	1	FR-4	
No.	Part Name 型号	Q'TY 数量	Material 材质	Remarks 备注

Specification for Transducer Model No. : KPT-G1420A-3542	Page	8/12
	Revision No.	1.0
	Drawing No.	OEM3542R

9. 包装标准 Packaging Standard

产品的外包装是纸箱,它应该清楚的标明型号,数量,出厂检验批号.
在运输及储存的过程中,产品必须不会受到机械损伤.

Each minimum package unit of products shall be in a carton box and it shall be clearly marked with Part Number, quantity and outgoing inspection number.

There shall be no mechanical damage on products during transportation and/or in storage.

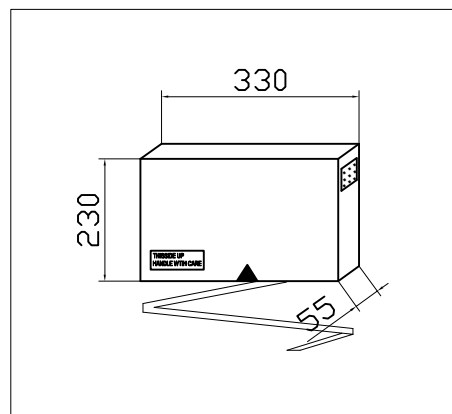
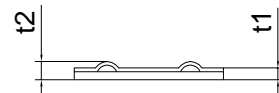
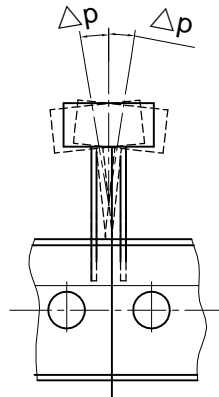
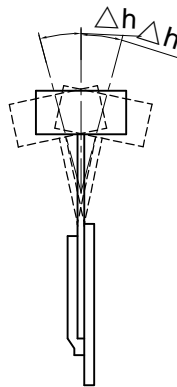
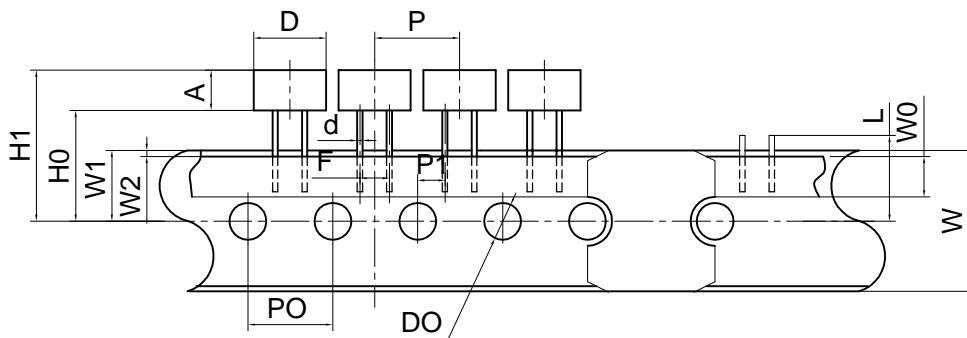

QTY: 350Pcs
SIZE:330x55x230mm

Eligibility Certificate		42
Company Name: NingBo KEPO Electronics co.,LTD		
P/N:	QTY: 350PCS	
Production Date:	Inspector:	
Shipment Date:		
Lot Number:		
ROHS Compliance		
76		

合格证标贴(根据实际要求填写)

收货单位	杭州松下厨房电器有限公司	85
部品编号	TG1420A3542	
订单番号	210430929	
工厂型号	KPT-G1420A-3542	
QTY	350PCS	
生产日期	2010/08/31	
生产厂家	宁波凯普电子有限公司	
65		

客户物料标贴(根据实际要求填写)

Specification for Transducer Model No. : KPT-G1420A-3542	Page	9/12
	Revision No.	1.0
	Drawing No.	OEM3542R

表 2 Table 2

名称 Name	代号 Symbol	尺寸 Dimension	公差 Tolerance	参考 preference
产品直径 Product Diameter	D	Ø14.2	±0.5	
插针直径 Pin Diameter	d	Ø0.60	±0.5	
产品间距 Product Distance	P	15.0	±1.0	
纸带孔间距 Paper Tape Hole Distance	P0	15.0	±0.3	
定位间距 Orientation Distance	P1	5.0	±0.7	
插针间距 Pin Distance	F	5.0	±0.5	
产品前后偏移量 The offset in the fore-and-aft direction	△h	2.0	Max.	
产品左右偏移量 The offset in the right-and-left direction	△p	1.3	Max.	
纸带宽度 Paper Tape Width	W	18.0	±0.5	
胶带宽度 Adhesive take width	W0	5.0	Min.	
定位间距 Orientation distance	W1	9.0	±0.5	
胶带下限位置 Adhesive tape lower limit position	W2	3.0	Max.	
产品下限位置 Product low limit position	H0	18.0	+0.2 -0	
产品上限位置 Product upper limit position	H1	46.5	Max.	
孔直径 Hole Diameter	DO	Ø4.0	±0.2	
胶带厚度 Adhesivetape thickness	t1	0.6	±0.3	
	t2	1.5	Max.	

Specification for Transducer Model No. : KPT-G1420A-3542	Page	10/12
	Revision No.	1.0
	Drawing No.	OEM3542R



Picture 1 350PCS



Picture 2 350PCS



Picture 3 3500PCS



Picture 4 3500PCS

Q'TY:3500PCS(10 Box)
SIZE:470X340X285mm

Specification for Transducer Model No. : KPT-G1420A-3542	Page	11/12
	Revision No.	1.0
	Drawing No.	OEM3542R

10. 警告 Cautions

如果产品使用于下列高可靠性的装置时,请与我们取得联系,以免对人的生命,财产和身体造成损害.

Please contact us before using our products for the undermentioned applications requiring especially high reliability in order to prevent defects which might directly cause damage to other party's life, body or property (listed below).

- (1) Aircraft equipment 飞行设备
- (2) Aerospace equipment 航天设备
- (3) Undersea equipment 潜水设备
- (4) Medical equipment 医疗设备
- (5) Transportation equipment (automobiles, trains, ships) 交通设施
- (6) Traffic signal equipment 交通信号设备
- (7) Disaster prevention/crime prevention equipment 防灾害/防犯罪设备
- (8) Data-processing equipment 数据处理设备
- (9) Applications of similar complexity or reliability requirements comparable to the applications listed in the above 以及与上述相类似或可靠性要求更高的设备

11. 注意事项 Cautions for Use

- 11.1 如果产品所承受的机械应力超过规定的值,元件可能被破坏.

The component may be damaged if mechanical stress over this specification is applied.

- 11.2 请注意保护工作电路不会因失误,跌落和温度变化而产生浪涌电压.

Please pay attention to protect operating circuit from surge voltage provided by something of force such as failing, shock and temperature changing.

- 11.3 请注意永远不要给压电声响器施加直流电压.

Please pay attention never to be applied DC voltage to piezo sounder.

- 11.4 该声响器不适合洗涤,因为它不密封.

Washing of the component is not acceptable. Because it is not sealed.

- 11.5 在使用烙铁的情况下,应注意烙铁头的温度应该保持在+350℃以下,并且焊接时间控制在3秒内.

In case of using solder iron for soldering, the top of soldering iron's temperature should be kept less than +350 °C. Moreover the soldering time should be also kept with in 3seconds.

- 11.6 符合RoHS指令及Panasonic电器集团[化学物质管理等级指针] (详见Panasonic电器网站首页)的规格.

RoHS compliance and Meet Panasonic Electric Group standard [chemical substance management level] (see Panasonic Electric Home)

Specification for Transducer	Page	12/12
	Revision No.	1.0
	Drawing No.	OEM3542R

Model No. : KPT-G1420A-3542

12. Revision

Rev. No.	DATE	PAGE	DESCRIPTION	SIGN
1.0	2009.02.10	/	primary	