



Piezoceramics Components - Filters / Discriminators / Traps

●	Ceramic Filters / 陶瓷滤波器	
○	For Communication - LTM 455/450 Series -----	1
○	For Communication - LTB Series -----	3
○	High-Selectivity for TV/VCR Stage -----	4
○	450 kHz Search-Stop Signal Detection - LZU Series -----	5
○	LTZ for AM Series -----	6
○	LTP for AM Series -----	7
○	Chip Ceramic Filters LTCS10.7M Series / 贴片陶瓷滤波器 -----	8
○	Low Spurious for TV/VCR Stage LTS MCB/ MDB Series -----	9
○	For Communication - LTC 455/450 Series -----	10
○	For Communication - LT465A Series -----	12
○	LT Miniature for AM Series -----	13
○	LT10.7 Series -----	14
○	For Communication LT 455/450 U/W Series -----	16
○	LT MB for TV/VCR Stage Series -----	18
○	SMD Ceramic Filters for AM Chip-LTCA/CV10.7M Series -----	19
●	Ceramic Discriminators / 陶瓷鉴频器	
○	For FM - JT10.7M Serie -----	20
○	For Communication - JTM Series -----	22
○	For Communication - JTC Series -----	23
○	Chip Ceramic Discriminators for FM - JTCV10.7M Series -----	24
●	Ceramic Traps / 陶瓷陷波器	
○	Ceramic Trap Filter for Chrominance Carrier XT MJ/MB Series -----	26
○	Trap Filters Double Type - XT MW Series -----	27
○	Trap Filters for TV/VCR Stage - XT MB Series -----	28
○	Triple Trap Filters - XT MT Series -----	29
○	Radial Taping Dimensions of Resonators and Filters -----	30
○	Piezo dielectric microwave devices-Precaution usage -----	33

Notice: Specification Changed or Version Updated will be posted at irregular intervals.
All Updated and Final Specifications, Please Confirm with TOKEN ELECTRONICS REPRESENTIVES.



<http://www.token.com.tw>



rfq@tokenonline.net

Taiwan: No. 137, Sec. 1, Chung Shin Rd., Wu Ku Hsiang, Taipei Hsien, Taiwan, R.O.C
TEL: 886-2-2981 0109; FAX: 886-2-2988 7487

China: 12F, Zhongxing Industry Bld., Chuangye Rd., Nanshan District, Shenzhen, Guangdong
TEL: 86-755-2605 5363, 2605 5364; FAX: 86-755-2605 5365



Filters

Ceramic Filters for Communication - LTM 455/450 Series

Token LTM 455/450 U/W Series Filter are miniaturized versions of the Murata Ceramic Filters CFU/CFWS lines. These compact, highly selective characteristics are recommended for use in applications ranging from two-way radio to auxiliary filters in high class transceivers. These ultra-miniature versions consume approximately 40% less volume while still offering the same high performance filter characteristics.

► LTM 455/450 U/W for Communication (Murata CFUM/WM 455/450 Compatible) 455 kHz / 450 kHz

Ceramic Filter LTM 455/450 U/W Series Technical Characteristics

Part Number		Center Frequency (kHz)	Insertion Loss (dB) max	Pass Band Ripple (dB) max	6dB Band Width (kHz) min	40dB Band Width (kHz) max	50dB Band Width (kHz) max	Spurious Attenuation fo±100kHz (dB) min		Input / Output Impedance (Ω)
								(LTM 455 U)	(LTM 455 W)	
LTM455AU	LTM455AW	455±2.0	4	2	±17.5	±40	±35	28	40	1000
LTM455BU	LTM455BW	455±2.0	4	2	±15	±30	±30	28	40	1500
LTM455CU	LTM455CW	455±2.0	4	2	±12.5	±24	±24	28	40	1500
LTM455DU	LTM455DW	455±1.5	4	2	±10	±20	±20	28	40	1500
LTM455EU	LTM455EW	455±1.5	6	2	±7.5	±15	±15	28	40	1500
LTM455FU	LTM455FW	455±1.5	6	2	±6	±12.5	±12.5	28	40	2000
LTM455GU	LTM455GW	455±1.5	6	2	±4.5	±10	±10	28	40	2000
LTM455HU	LTM455HW	455±1.0	6	2	±3	±9	±9	28	40	2000
LTM455IU	LTM455IW	455±1.0	6	2	±2	±7.5	±7.5	28	40	2000
LT M455HTU	LT M455HTW	455±1.0	6	2	±3	±9	±9	35	60	2000

• Center frequency 450KHz is also available.

► Ceramic Filter LTM 455/450 U/W Series Dimensions

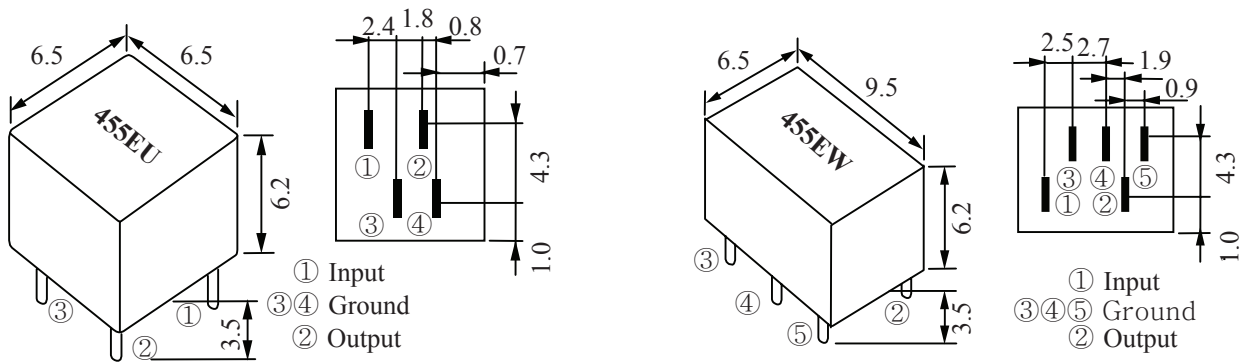



Filters

▶ LTM 455/450 U/W Series Ceramic Filter Test Circuit

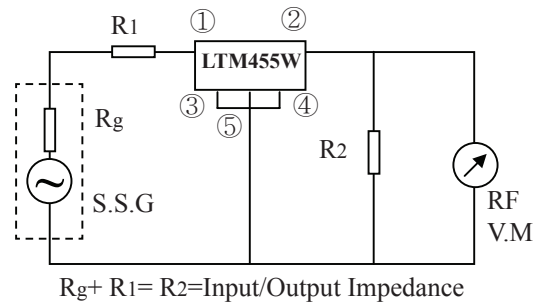
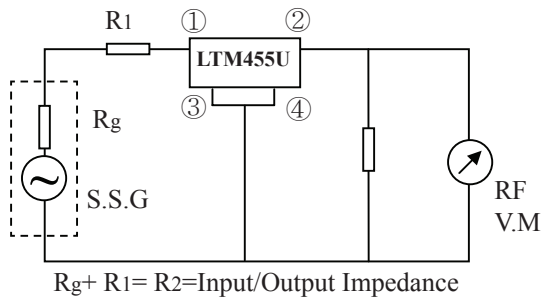

▶ Ceramic Filter LTM 455/450 U/W Series Characteristics

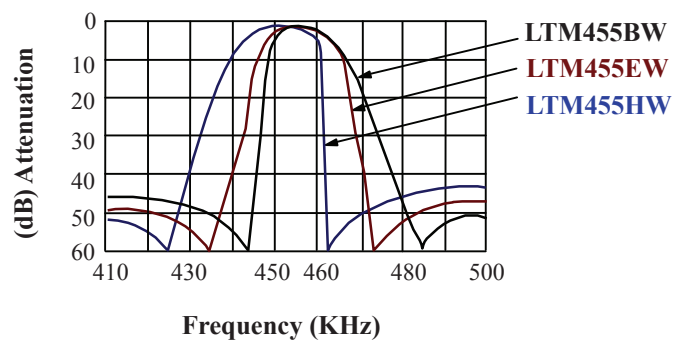
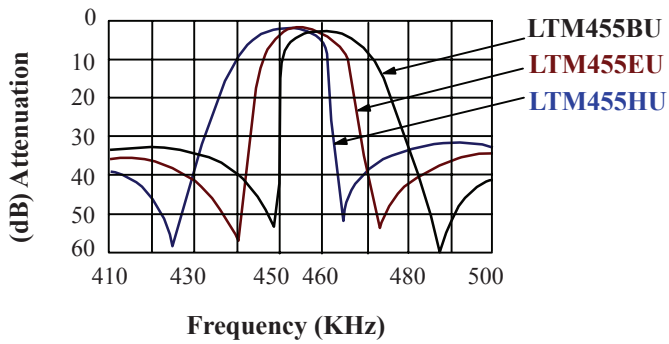

▶ Ceramic Filter How to Order



- ① Part Number
- ② Packaging



Filters

Piezoceramics Filters for Communication - LTB Series

► Piezoceramics Filter LTB Series for Communication

450 ~ 470 kHz

Token LTB series Piezoceramic Filter comprises small, high performance. Their innovative construction is perfect for shrinking mobile communication products such as pocket pagers and cellular phones. Operating temperature range: -20 to +80 (°C); Storage temperature range: -40 to +85 (°C)

► Piezoceramics Filters - LTB Series for Communication Technical Characteristics

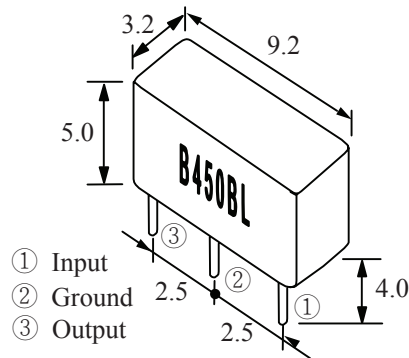

Part Number	Center Frequency (fo) (kHz)	6dB Band Width (kHz) min	Selectivity ± 9kHz off (dB) min	Pass Band Ripple (dB) max	Insertion Loss (dB) max	Input/ Output Impedance (Ω)
LTB450AL2	450±2	4	18	1.0	6.8	1.0/1.5
LTB455AL2	455±2					
LTB465AL2	465±2					
LTB450BL2	450±2	6	16	1.0	5.8	1.5/2.0
LTB455BL2	455±2					
LTB465BL2	465±2					

► Piezoceramics Filter LTB Series Test Circuit

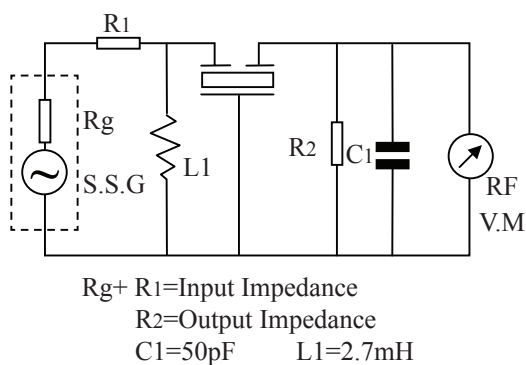

► LTB Series Characteristics

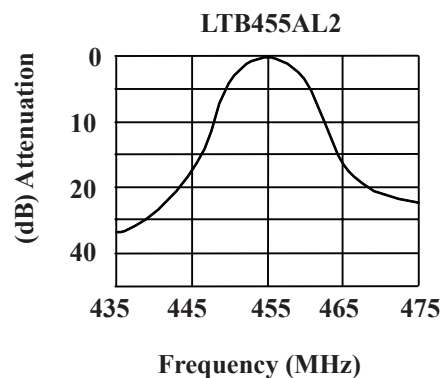

► How to Order



① Part Number

② Packaging



Filters

Ceramic Filters High-Selectivity for TV/VCR Stage

Token High-Selectivity LTT Series Filter is 4 element devices that offer more selectivity than the conventional LT series (Murata SFE). The improved spurious suppression of these filters eliminates the need for cascading multiple filtering devices; therefore, it is possible to design a more compact circuit board configuration.

► LTT High-Selectivity Series for TV/VCR Stage (Murata SFT Series Compatible) 4.5 MHz ~ 6.74 MHz

Ceramic Filter LTT MA Series Technical Characteristics

Part Number	Nominal Center Frequency (fo) (MHz)	3dB Band Width (kHz) min	20dB Band Width (kHz) max	Insert Loss (dB) max	Spurious Attenuation (dB) min	Input/Output Impedance (Ω)
LTT4.5MA	4.500	fo±40	370	10.0	40(4.5 ^{+0.8} _{-1.0} MHz)	1000
LTT4.72MA	4.724	fo±40	370	10.0	40(4.72 ^{+0.8} _{-1.0} MHz)	1000
LTT5.5MA	5.500	fo±50	350	9.0	40(5.5±1MHz)	600
LTT5.74MA	5.742	fo±50	350	9.0	50(5.74±1MHz)	600
LTT6.0MA	6.000	fo±50	400	9.0	50(6.0±1MHz)	470
LTT6.25MA	6.250	fo±50	400	9.0	50(6.25±1MHz)	470
LTT6.5MA	6.500	fo±50	400	9.0	50(6.5±1MHz)	470
LTT6.74MA	6.742	fo±50	400	9.0	50(6.74±1MHz)	470

► Ceramic Filter LTT MA Series Dimensions

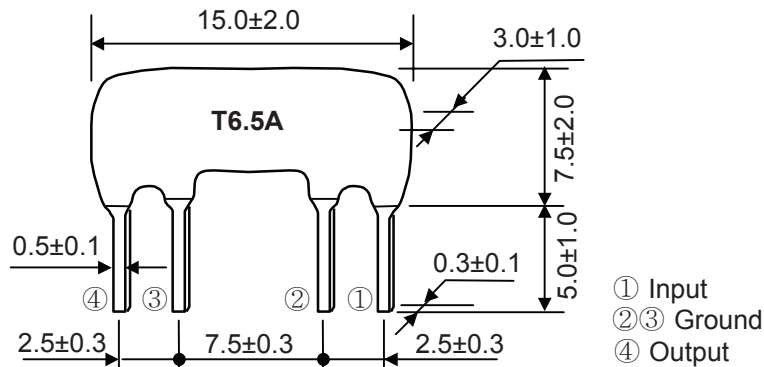

► Ceramic Filters - LTT MA Series Test Circuit

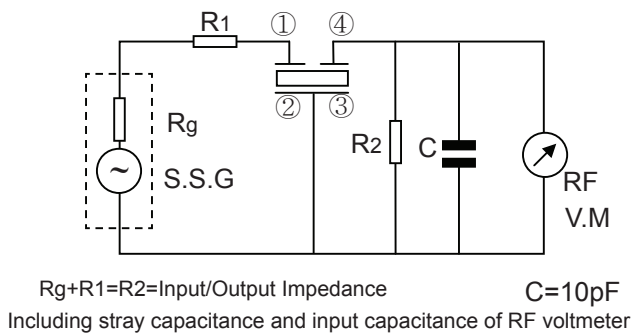

LTT MA Series Characteristics

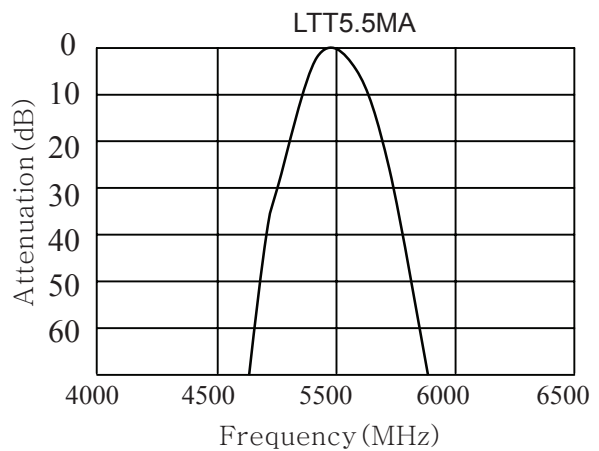

► How to Order



① Part Number ② Packaging



Filters

Ceramic Filters 450 kHz Search-Stop Signal Detection - LZU Series

Token LZU 450 kHz Filter search-stop signal detection are specifically designed for signal detection circuitry used in applications such as that found in the search-stop functions of electronically tuned radios. Center frequency is also available in LTZ series a range of 450 kHz ~ 470 kHz.

▶ LZU for Search-stop Signal Detection (Murata BFU Series Compatible)

450 kHz

Ceramic Filters - LZU Series Technical Characteristics

Part Number	Resonant Frequency (kHz)	Resonant Resistance (Ω) (max)	Band Width(fa-fr) (kHz)	Application
LZU450C	450 \pm 1.0	20	14 \pm 2	IF signal detection
LZU450C4N	450 \pm 0.8	30	9 \pm 2	
LZU450K3	450 \pm 1.0	30	27.5 \pm 4.5	

▶ Ceramic Filter LZU Series Dimensions

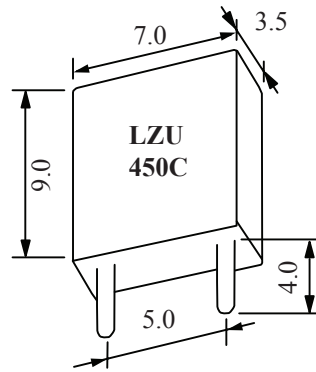

▶ Ceramic Filter LZU Series Test Circuit

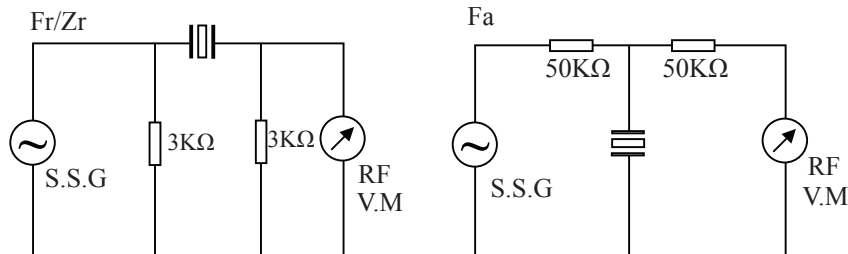

▶ How to Order



- ❶ Part Number
- ❷ Packaging



Ceramic Filters

Ceramic Filters - LTZ for AM Series

Token LTZ Series Filter are designed to address the needs of standard AM filtering requirements and are recommended for use in low cost products where economically, efficient designs are critical.

▶ LTZ Series for AM (Murata SFZ Series Compatible)

450 kHz ~ 470 kHz

Ceramic Filter LTZ Series Technical Characteristics

Part Number	Center Frequency (fo) (kHz)	3dB BandWidth (kHz)	Selectivity ±9kHz off (dB) min	InsertionLoss (dB)	Composition
LTZ455HL	455.5±2.0	4.0±1	23	7	2 elements direct coupling type
LTZ455JL	456.0±2.0	5.5±1	18	7	

• Center Frequency (fo) is available in a range of 450 ~ 470kHz.

The nominal frequency tolerance is ± 2kHz.

▶ Ceramic Filter LTZ Series Dimensions

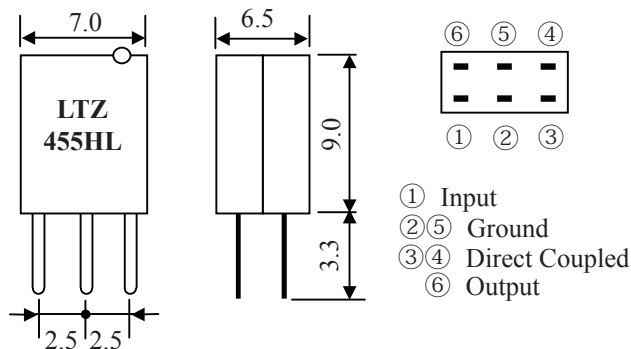

▶ Ceramic Filter Recommended IFT (7mm Square)

Item	LTZ455HL/JL		
Winding Specification	①~②	②~③	④~⑥
Form bottom	68T	84T	14T
unloaded Qu	90		
Tuning Capacity	108PF		

▶ Ceramic Filter LTZ Series Test Circuit

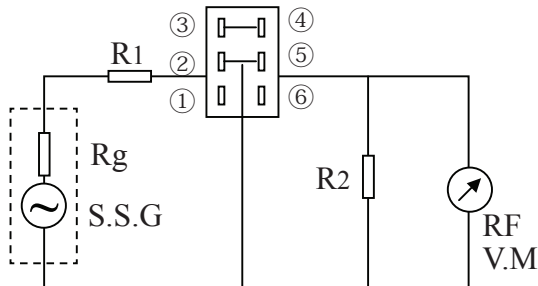

$$R_g + R_1 = R_2 = 3K\Omega$$

LTZ Series Characteristics

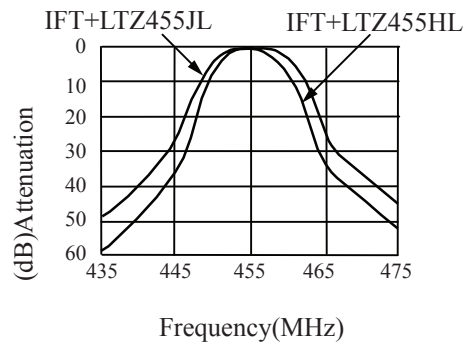

▶ How to Order



① Part Number

② Packaging





Ceramic Filters

Ceramic Filters - LTP for AM Series

Token LTP Series Filter are designed to address the needs of standard AM filtering requirements. These filters are recommended for use in low cost products where economically, efficient designs are critical.

▶ LTP for AM (Murata SFU450/455kHz Compatible)

450kHz ~ 470kHz

Ceramic Filter LTP Series Technical Characteristics

Part Number	3dB Band Width (kHz)	Center Frequency (fo) (kHz)	Selectivity(dB)min		Insert Loss (dB) max	Composition	Lead Length L (mm)	
			-9kHz off	+9kHz off			L1	L2
LTP455A	9.5±3	455±2	5.0	3.0	5.0	one element	3.6	5.0
LTP455B	9.5±3	462±2	5.0	3.0	5.0	one element with IFT		
LTP450BY	7±2	455±2	6.0	5.0	5.0			
LTP450BY1	4.5±1.5	452.5±2	9.0	8.0	5.0			

- Center Frequency (fo) is available in a range of 450~470kHz. The nominal frequency tolerance is ±2kHz.

▶ Ceramic Filters - LTP Series Dimensions

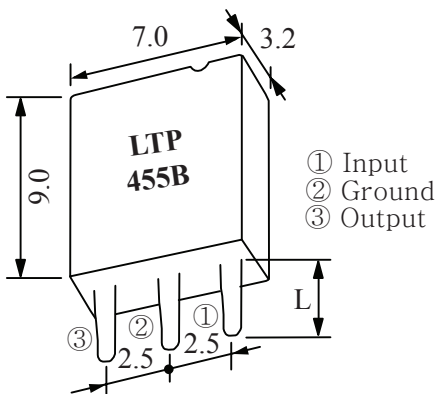

Recommended IFT (7mm Square)

Item	LTP 455B		
Winding Specification	①~②	②~③	④~⑥
 Form bottom	70T	115T	7T
unloaded Qu	105		
Tuning Capacity	108PF		

▶ Ceramic Filters - LTP Series Test Circuit

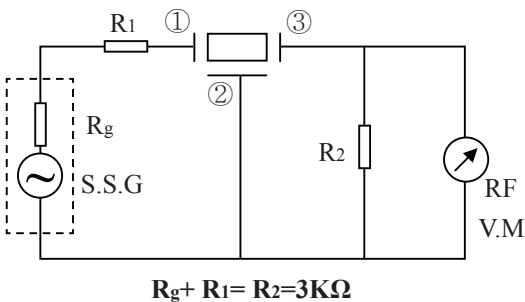

LTP Series Characteristics

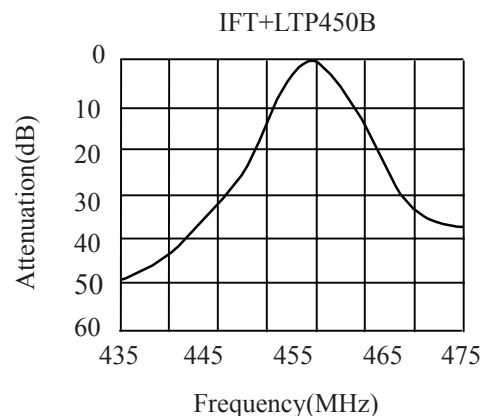

▶ How to Order



- ① Part Number
- ② Packaging



Filters

Chip Ceramic Filters LTCS10.7M Series

▶ LTCS10.7M (Compatible to Murata SF ECS10M7)

10.7MHz

Chip Ceramic Filter LTCS10.7M series (Compatible to Murata SF ECS10M7) for FM-receivers are small, high performance and super thin (1.5mm max.). Piezoelectric element is connected in the sandwich shape by piezo substrate.

▶ Chip Ceramic Filter Features

1. Mountable by automatic placers.
2. Slim at only 1.5mm max. thickness, and have a small mounting area enabling flexible PCB design.
3. Various bandwidths are available. Select a suitable type in accordance with the desired selectivity.
4. Operating temperature range: -20 to +80 (°C)
Storage temperature range: -40 to +85 (°C)

▶ Applications

1. Small, thin radios
2. Headphone stereos

▶ Chip Ceramic Filter SMD Type LTCS10.7M Technical Characteristics

Part Number	3dB Band Width (kHz)	20dB Band Width (kHz)max	Insertion Loss (dB)max	Spurious Attenuation (9-12MHz)(dB)min
LTCS10.7MS2	230±50	510	3.5±2.0	30
LTCS10.7MS3	180±40	470	4.5±2.0	30
LTCS10.7MA5	280±50	590	3.0±2.0	30
LTCS10.7MA20	330±50	700	3.0±2.0	30

● Input/Output Impedance:330Ω

▶ LTCS10.7M Dimensions (Unit: mm)

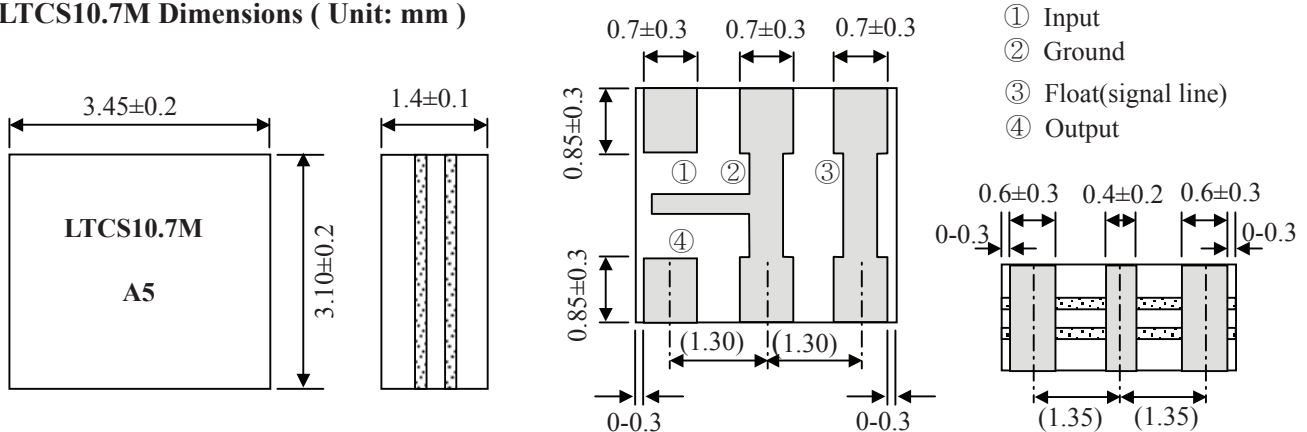

▶ Chip Ceramic Filter LTCS10.7M Test Circuit

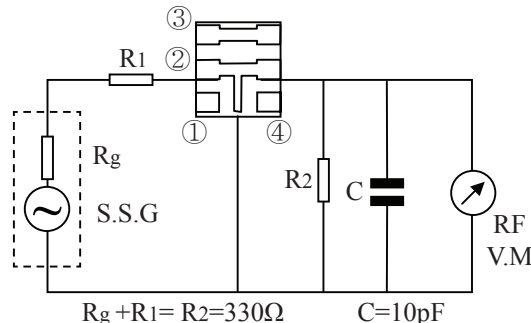

Including stray capacitance and input capacitance of RF voltmeter

▶ How to Order



- ① Part Number ② Packaging:(T : Taping Reel)



Filters

Piezoceramics Filter Low Spurious for TV/VCR Stage LTS MCB/MDB Series

Token LTS MCB/MDB Filter Low Spurious Series use thickness shear vibration mode. Features with excellent spurious characteristics within Video Signal Band, and 3 types bandwidths prepared to respond customer requests. LTS MCB/MDB is suitable for Multiplex Sound TV in America.

▶ LTS MCB/MDB Series for TV/VCR Stage with Low Spurious (Murata SF5H MCB/MDB Compatible)

4.5 MHz ~ 6.5 MHz

Piezoceramics Filter LTS MCB/MDB Series Technical Characteristics

Part Number	Nominal Center Frequency (fo) (MHz)	3dB Band Width (kHz) min	20dB Band Width (kHz) max	Insert Loss (dB) max	Spurious Attenuation (0~fo) (dB) min	Input/Output Impedance (Ω)
LTS4.5MCB	4.500	fo±60	600	6.0	30	1000
LTS4.5MDB	4.500	fo±70	750	6.0	30	1000
LTS5.5MCB	5.500	fo±60	600	6.0	30	600
LTS5.5MDB	5.500	fo±80	750	6.0	30	600
LTS6.0MCB	6.000	fo±60	600	6.0	30	470
LTS6.0MDB	6.000	fo±80	750	6.0	30	470
LTS6.5MCB	6.500	fo±70	650	6.0	30	470
LTS6.5MDB	6.500	fo±80	800	6.0	30	470

▶ Piezoceramics Filter LTS MCB/MDB Series Dimensions

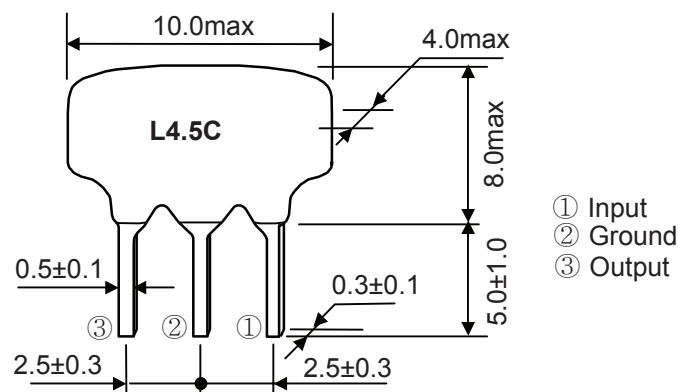

- ① Input
- ② Ground
- ③ Output

▶ Piezoceramics Filter LTS MCB/MDB Series Characteristics

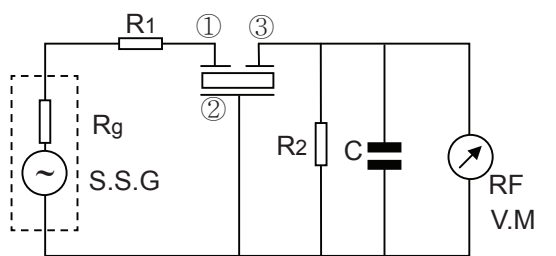

$R_g + R_1 = R_2 = \text{Input/Output Impedance}$
Including stray capacitance and input capacitance of RF voltmeter
 $C = 10\text{pF}$

LTS MCB/MDB Series Characteristics

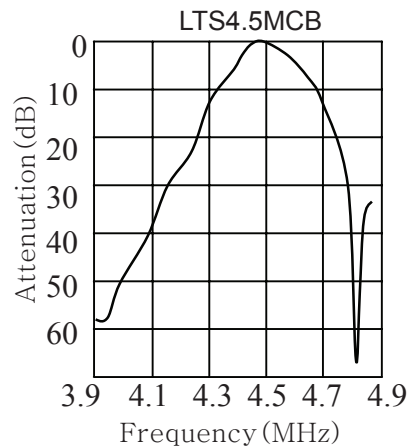

▶ How to Order



- ① Part Number
- ② Packaging



Piezoceramics Filters for Communication - LTC 455/450 Series

Token Piezoceramics components LTC455/450 U/W series Filter for IF (Compatible to Murata CFUCG series) comprises small, high performance, thin (4.0mm) consisting of 4 ceramic elements. Their innovative construction is perfect for shrinking mobile communication products such as pocket pagers and cellular phones.

► Piezoceramics Filters for Communication Features

1. Mountable by automatic placers.
2. Can be reflow soldered and withstand washing.
3. They are slim, at only 4.0mm max. thickness, and have a small mounting area enabling flexible PCB design.
4. The bandwidth ranges from D to G.
5. Operating temperature range: -20 to +80 (°C)
Storage temperature range: -40 to +85 (°C)

► LTC 455/450 U/W Series (Compatible to Murata CFUCG series)

455 kHz / 450 kHz

Piezoceramics Filters LTC 455/450 U/W Series Technical Characteristics

Part Number		Center Frequency (fo)(kHz)	Insertion Loss (dB) max		Pass Band Ripple (dB) max	6dB Band Width (kHz) min	40dB Band Width (kHz) min	50dB Band Width (kHz) min	Spurious Attenuation fo±100kHz (dB) min		Input / Output Impedance (Ω)
			LTC 455U	LTC 455W					LTC 455U	LTC 455W	
LTC 455BU	LTC 455BW	455±1.5	4	4	2	±15.0	±30	±30	27	50	1000
LTC 455CU	LTC 455CW	455±1.5	4	4	2	±12.5	±25	±25	27	50	1000
LTC 455DU	LTC 455DW	455±1.5	4	4	2	±10.0	±20	±20	27	50	1500
LTC 455EU	LTC 455EW	455±1.5	6	4	2	±7.5	±15	±15	27	50	1500
LTC 455FU	LTC 455FW	455±1.5	6	6	2	±6.0	±12	±12	27	47	1500
LTC 455GU	LTC 455GW	455±1.5	6	6	2	±4.5	±10	±10	25	47	1500
LTC 455HU	LTC 455HW	455±1.5	6	6	2	±3.0	±9.0	±9.0	25	47	1500
LTC 455IU	LTC 455IW	455±1.5	6	6	2	±2.0	±7.5	±7.5	25	47	1500

• Center frequency 450KHz is also available.

► Piezoceramics Filters for Communication LTC 455/450 U/W Series Dimensions

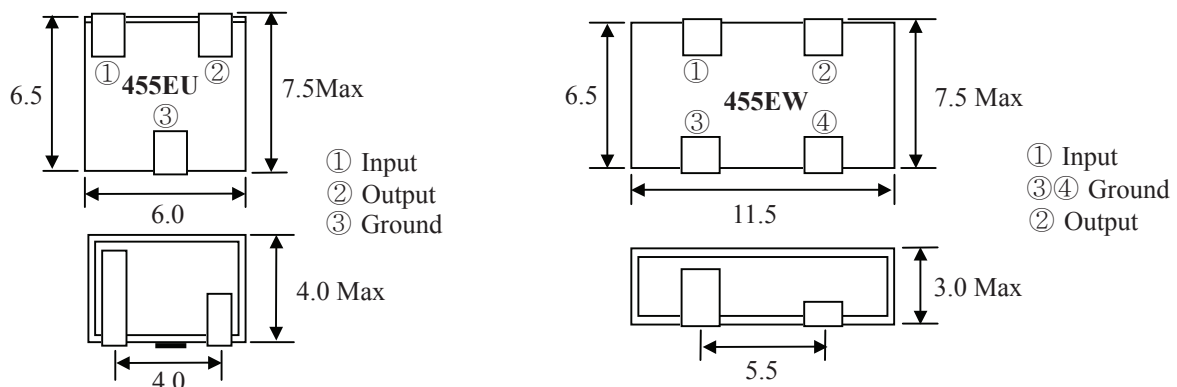



Filters

► Piezoceramics Filters for Communication LTC 455/450 U/W Series Test Circuit

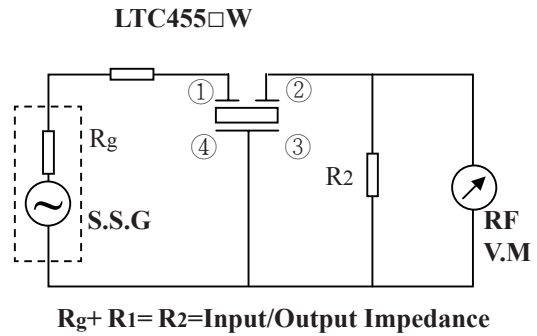
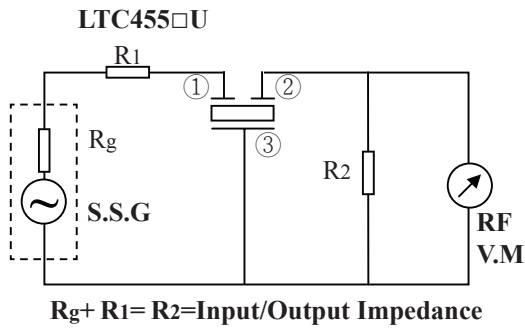

► Piezoceramics Filters for Communication LTC 455/450 U/W Series Characteristics

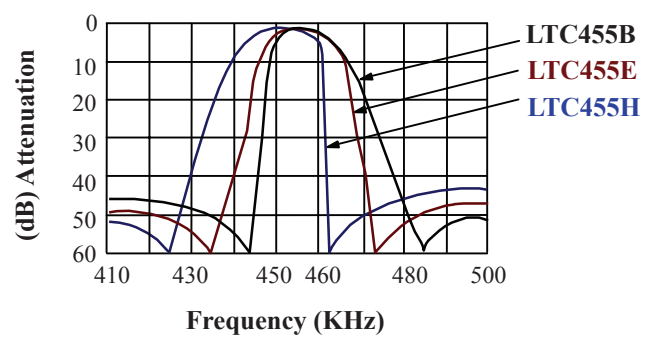
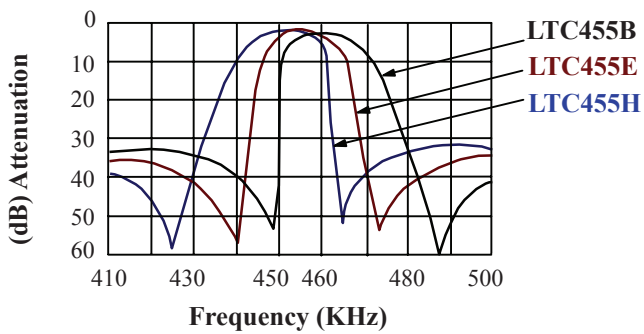

► How to Order

LTC455BU - T

① ②

① Part Number

② Packaging (T:Taping Reel)



Filters

Ceramic Filters for Communication - LT465A Series

Token LT465A Filter for Radio-Cassette Recorder were designed to address the needs of standard radio cassette recorder requirements. Recommend for use in low cost products where economically, efficient designs are critical. The nominal frequency tolerance is ± 2 KHz.

► LT for Radio Cassette Recorder

450 kHz ~ 470 kHz

Ceramic Filter LT Series Technical Characteristics

Part Number	Center Frequency (fo)(kHz)	Insertion Loss (dB)max	6dB Band Width (kHz)min	Spurious Attenuation (fo \pm 100kHz)(dB)min	Selectivity \pm 9kHz off (dB)min	Pass Band Ripple (dB)max	Input/Output Impedance (Ω)
LT450A	450 \pm 2	3	8	12	11	1	2
LT455A	455 \pm 2	3	8	12	11	1	2
LT465A	465 \pm 2	3	8	12	11	1	2

- Center Frequency (fo) is available in a range of 450 ~ 470kHz.
The nominal frequency tolerance is ± 2 kHz.

► LT Series Dimensions

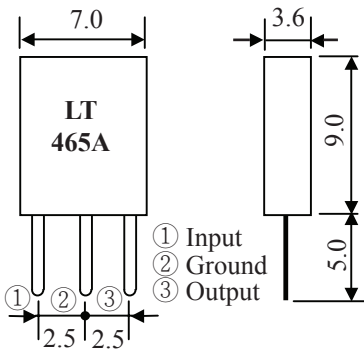

► LT Series Test Circuit

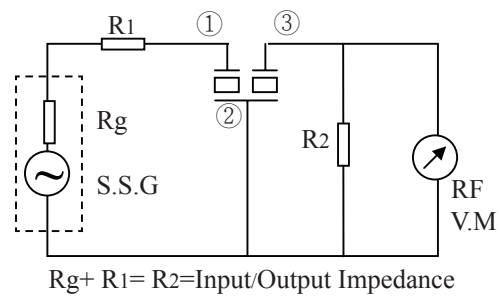

► Ceramic Filter LT Series Characteristics

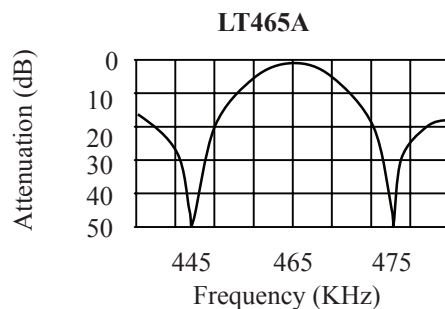

► How to Order



- ① Part Number
- ② Packaging



Filters

Ceramic Filter - LT Miniature for AM Series

Token LT Miniature for AM Filter is one of the most recommendable intermediate type, having such distinctive features as high selectivity, high stability and adjustment-free operation. Additionally its easy matching with IC helps create an easy circuit design such as applications in Electric synthesized tuners, HiFi audio systems, AM stereo demodulations, One-chip non-adjustment IC's, and even smaller, thinner set structure to cope with these diversifying for AM receiver. Features with center frequency between 450 and 470 kHz, standard tolerance ± 2 kHz, and synthesizers for the types of center frequencies 450, 459 and 468 kHz. Standard tolerance is ± 1 kHz.

▶ LT MINIATURE (Murata PFB Series Compatible)

450 kHz ~ 470 kHz

Ceramic Filter Miniature LT Series Technical Characteristics

Part Number	3dB Band Width (kHz)	Selectivity ± 9 kHz off (dB)	Insertion Loss (dB)	Composition
LT 455JR	5.5 ± 1.5	≥ 17	≤ 6	2 elements

- Center Frequency (f_0) is available in a range of 450 ~ 470kHz. The nominal frequency tolerance is ± 2 kHz.

▶ Miniature Series Dimensions

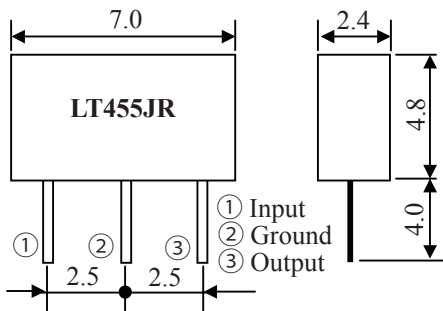

▶ Miniature LT Series Characteristics

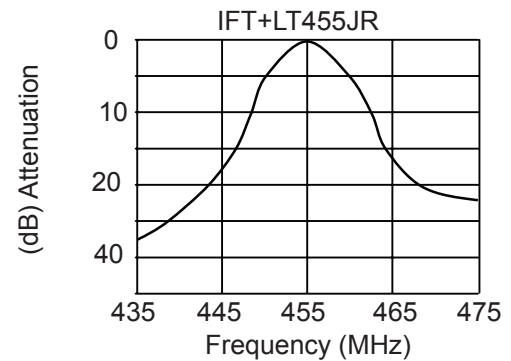

▶ Ceramic Filter Recommended IFT (7mm Square)

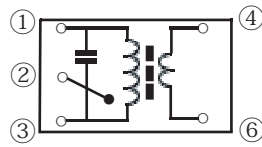
Item	7×7mm			5×5mm		
	①~②	②~③	④~⑥	①~②	②~③	④~⑥
Winding Specification	①~②	②~③	④~⑥	①~②	②~③	④~⑥
Form bottom 	85T	67T	23T	84T	98T	33T
unloaded Q_u	90			65		
Tuning Capacity	180PF			180PF		

▶ How to Order



- ① Part Number
- ② Packaging





Ceramic Filters

Ceramic Filters - LT10.7 Series

Token LT10.7 Series Ceramic Filter are monolithic devices which utilize the energy-trapped thickness vibration-mode. This principle of operation is based upon the fact that an excellent resonating element with low spurious vibration can be obtained by adhering to certain theoretical parameters of design. These parameters include the physical dimensions of the ceramic element, the electrode pattern, and the associated mass loading effect of the electrodes. In addition to employing the principle of energy-trapped thickness shear vibration-mode, Token also utilizes the theory of the multicoupling mode. In short, this theory utilizes divided electrodes to “trap” different frequencies simultaneously. The advantages of Token’s multicoupling mode technology is a highly selective, integrated device that allows a single piezo substrate to contain a number of coupled resonators. Token categorizes the LT 10.7 Filter family according to rank of center frequency. This ranking indicates that a given LT 10.7 will be marked with one of the colors listed in the following chart and will exhibit the center frequency characteristics specified below.

▶ **LT10.7M Series For FM Receiver(Murata SFE10M7 FM-IF Series Compatible)** **10.7MHz**

Ceramic Filter LT10.7M Series Technical Characteristics

Part Number	3dB Band Width (kHz)	20dB Band Width (kHz) max	Insertion Loss (dB) max	Spurious Attenuation (9-12MHz)(dB)min
LT10.7MA5	280±50	650	6	30
LT10.7MS2	230±50	600	6	40
LT10.7MS3	180±40	520	7	40

• Input/Output Impedance:330Ω

▶ **LT10.7M A10 Series Low - Loss Type(Murata SFE10M7 A10 Series Compatible)** **10.7MHz**

Ceramic Filter LT10.7M A10 Series Technical Characteristics

PartNumber	3dB Band Width(kHz)	20dB Band Width(kHz) max	Insertion Loss(dB)	Spurious Attenuation (9-12MHz)(dB)min
LT10.7MA5A10	280±50	590	2.5±2.0	30
LT10.7MS2A10	230±50	520	3.0±2.0	35
LT10.7MS3A10	180±40	470	3.5±1.5	35
LT10.7MJA10	150±40	360	4.5±2.0	35

• Input/Output Impedance:330Ω

▶ **Wide/Narrow Band-width LT10.7M Series(Murata SFE10M7 DBS Receiver Compatible)** **10.7MHz**

Ceramic Filter LT10.7M Series Technical Characteristics

Part Number	3dB Band Width (kHz)	20dB Band Width (kHz) max	Insertion Loss (dB)	Spurious Attenuation (9-12MHz)(dB)min
LT10.7MA19	350min	950	3.0±2.0	20
LT10.7MA20	330±50	680	4.0±2.0	30
LT10.7MHY	110±30	350	7.0±2.0	30
LT10.7MFP	20min	95	6.0max	24(10.7±1.0MHz)

• Input/Output Impedance:470Ω(MA19),330Ω(MA20,MHY),600Ω(MFP)



Ceramic Filters

► Ceramic Filter LT10.7M Dimensions

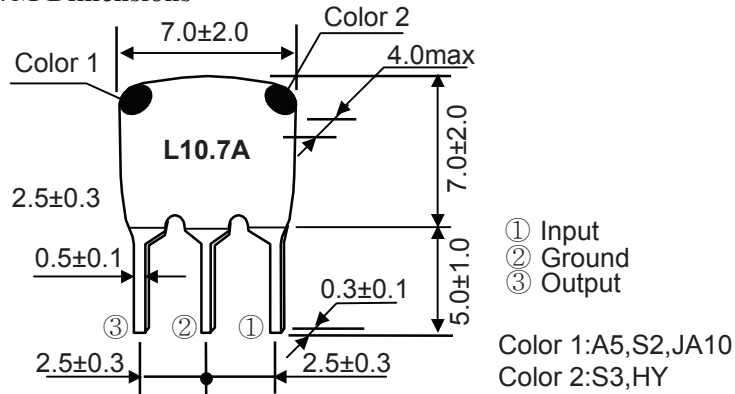

► Ceramic Filter LT10.7M Test Circuit

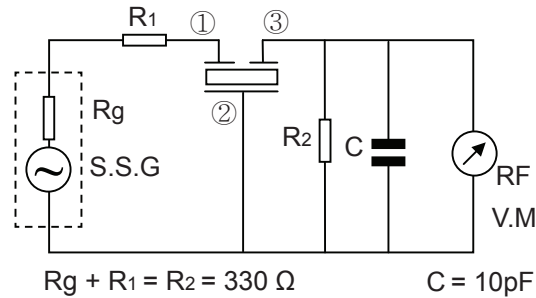

Including stray capacitance and input capacitance of RF voltmeter

► Ceramic Filter LT10.7M Standard Marking Color

Center Frequency	Color
D:10.64MHz±30kHz	Black
B:10.67MHz±30kHz	Blue
A:10.70MHz±30kHz	Red
C:10.73MHz±30kHz	Orange
E:10.76MHz±30kHz	White

► Ceramic Filter LT10.7M Characteristics

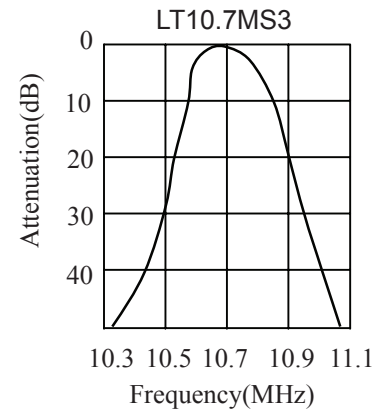
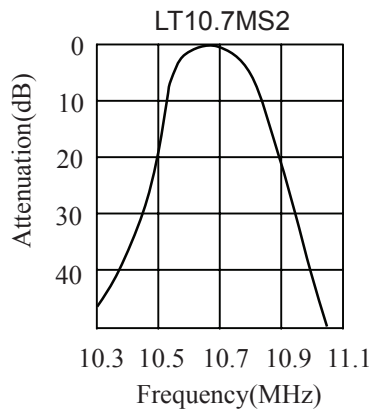
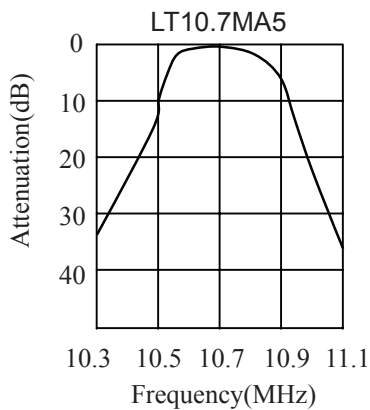

► How to Order

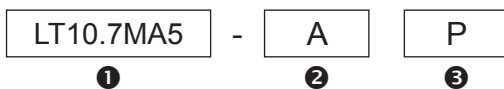



Filters

Communication LT 455/450 U/W Ceramic Filters

LT 455/450 U/W Filter are 4-element and 6-element devices connected in ladder form. These highly selective filters are designed to address the G.D.T. characteristics required in digital communications. The excellent G.D.T. characteristics allow these filters to be utilized in areas such as the mobile cellular markets as well as a variety of stereo applications. (Also available in 450kHz version.)

► LT 455/450 U/W for Communication (Murata CF, SF series Compatible) 455 kHz / 450 kHz

Ceramic LT 455/450 U/W Filters Technical Characteristics

Part Number		Center Frequency (kHz)	Insertion Loss (dB) max	Pass Band Ripple (dB) max	6dB Band Width (kHz) min	40dB Band Width (kHz) max (LT455 U)	50dB Band Width (kHz) max (LT455 W)	Spurious Attenuation fo±100kHz (dB) min		Input / Output Impedance (Ω)
								(LT455 U)	(LT455 W)	
LT455AU	LT455AW	455±2.0	4	2	±17.5	±40	±35	28	40	1000
LT455BU	LT455BW	455±2.0	4	2	±15	±30	±30	28	40	1500
LT455CU	LT455CW	455±2.0	4	2	±12.5	±24	±24	28	40	1500
LT455DU	LT455DW	455±1.5	4	2	±10	±20	±20	28	40	1500
LT455EU	LT455EW	455±1.5	6	2	±7.5	±15	±15	28	40	1500
LT455FU	LT455FW	455±1.5	6	2	±6	±12.5	±12.5	28	40	2000
LT455GU	LT455GW	455±1.5	6	2	±4.5	±10	±10	28	40	2000
LT455HU	LT455HW	455±1.0	6	2	±3	±9	±9	28	40	2000
LT455IU	LT455IW	455±1.0	6	2 </td <td>±2</td> <td>±7.5</td> <td>±7.5</td> <td>28</td> <td>40</td> <td>2000</td>	±2	±7.5	±7.5	28	40	2000
LT455HTU	LT455HTW	455±1.0	6	2	±3	±9	±9	35	60	2000

● Center frequency 450kHz is also available.

► Ceramic LT 455/450 U/W Filter Dimensions

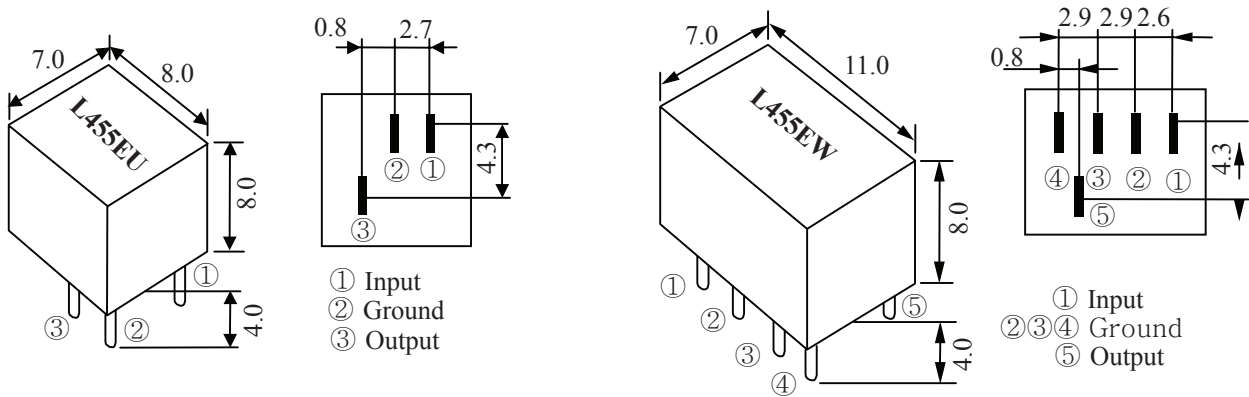

► Ceramic LT 455/450 U/W Filter Test Circuit

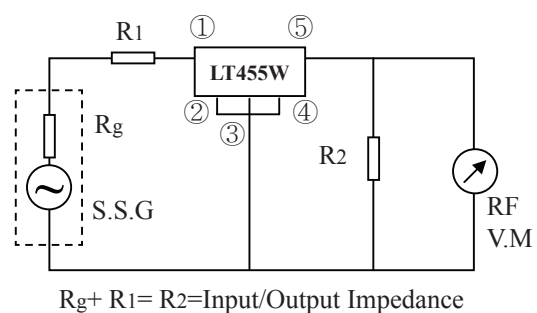
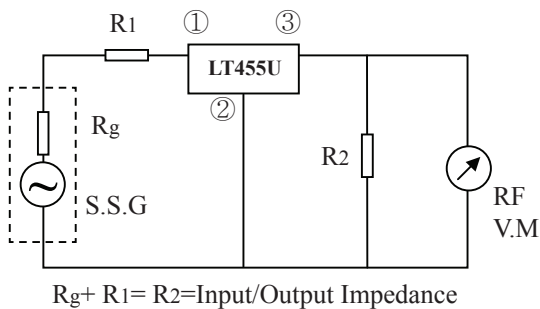



Filters

► Ceramic LT 455/450 U/W Filter Characteristics

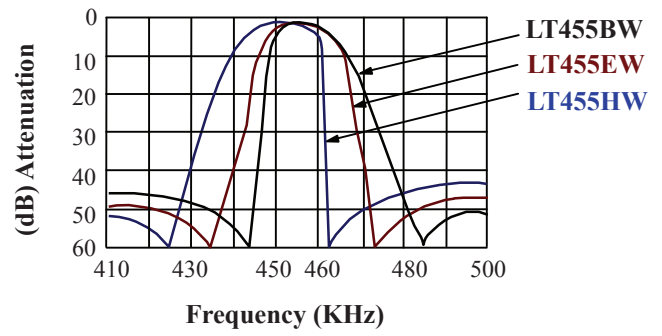
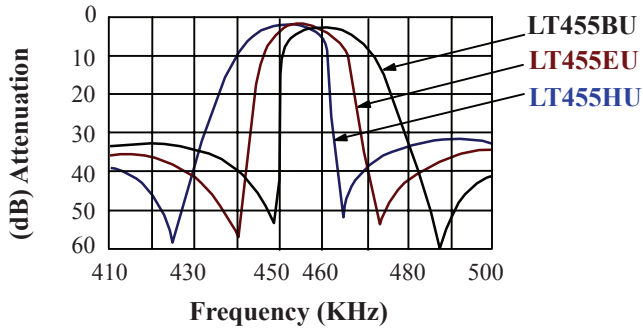

► How to Order

LT455BU - P

① ②

① Part Number

② Packaging





Filters

Piezoceramics Filters - LT MB for TV/VCR Stage Series

▶ LT MB Series for TV/VCR Stage (Murata SFE MB series Compatible)

4.5 MHz ~ 6.5 MHz

LT MB Series Piezoceramics Filter are a high selectivity filter for 2 channel multi-sound TV. Features with frequency adjustment-free, high performance and durability, and high selectivity.

▶ Piezoceramics Filter LT MB Series Technical Characteristics

Part Number	Nominal Center Frequency (fo) (MHz)	3dB Band Width (kHz) min	20dB Band Width (kHz) max	Insert Loss (dB) max	Spurious Attenuation (dB) min	Input/Output Impedance (Ω)
LT4.5MB	4.500	fo±60	530	6.0	20(4.5 ^{+0.8} _{-1.0} MHz)	1000
LT5.5MB	5.500	fo±75	550	6.0	25(5.5±1MHz)	600
LT6.0MB	6.000	fo±80	600	6.0	25(6.0±1MHz)	470
LT6.5MB	6.500	fo±80	630	6.0	25(6.5+1MHz) 30(6.5-1MHz)	470

▶ Piezoceramics Filter LT MB Series Dimensions

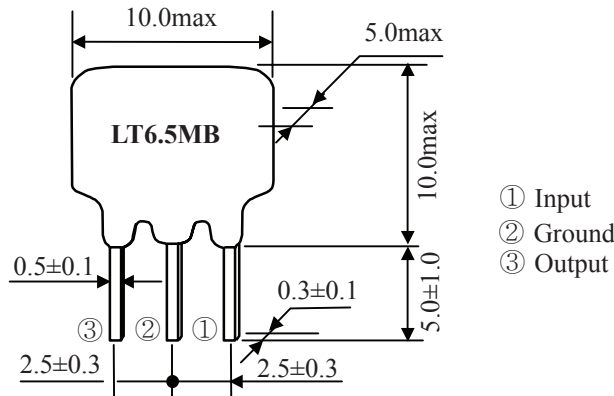

▶ Piezoceramics Filters - LT MB Series Test Circuit

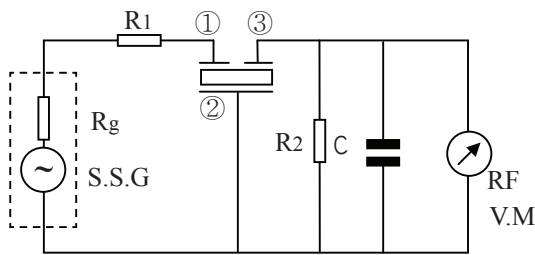

Rg+R1=R2=Input/Output Impedance
Including stray capacitance and input capacitance of RF voltmeter
C=10pF

LT MB Series Characteristics

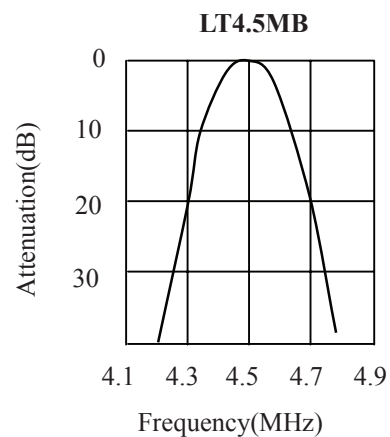

▶ How to Order



- ① Part Number
- ② Packaging



Filters

SMD Ceramic Filters for AM Chip-LTCA/CV10.7M Series

Chip LTCA/CV10.7M AM type Filter has been made smaller, thinner and in a chip configuration for surface mounting. This is one more example of Token's leadership in converting conventional electronic components to chip technology.

▶ LTCA/CV10.7M (Compatible to Murata SFECV10M7)

10.7MHz

Chip Type LTCA/CV10.7M Technical Characteristics

Part Number	3dB BandWidth (kHz)	20dB Band Width (kHz) max	Insertion Loss (dB)max	Spurious Attenuation (9-12MHz)(dB)min
LTCA10.7MJ	150±40	430	10.0	30
LTCV10.7MJ	150±40	380	5.5±2.0	35
LTCA10.7MA5	280±50	650	6.0	30
LTCV10.7MA5	280±50	590	3.0±2.0	35
LTCA10.7MS2	230±50	570	6.0	30
LTCV10.7MS2	230±50	510	3.5±2.0	35
LTCA10.7MS3	180±40	520	6.0	30
LTCV10.7MS3	180±40	470	4.0±2.0	35

● Input/Output Impedance:330Ω

▶ SMD Ceramic Filter LTCA/CV10.7M Dimensions (Unit: mm)

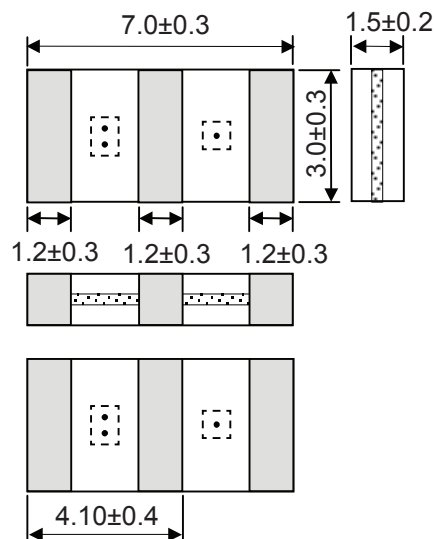

▶ How to Order

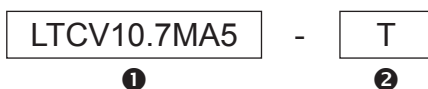

① Part Number

② Packaging (T:Taping Reel)



Discriminator

Ceramic Discriminator for FM - JT10.7M Series

▶ Ceramic Discriminator JT10.7M For FM (Murata CDA 10.7 Compatible)

10.7MHz

JT10.7M Series Discriminator for FM are resonated devices that offer adjustment free audio detection in both wide and narrow bandwidths. These IC dependent devices utilize FM specific detection methods to convert changes in frequency into an intelligible audio signal.

▶ Ceramic Discriminator JT10.7M Series For FM Technical Characteristics

Part Number	Demodulation Output at fo (mv) min	Distortion Factor at fo (%) max	Demodulation 3dB Band Width (kHz) max	Applicable IC
JT10.7MG1	25	1.0	345	CX-2009,CX-20111
JT10.7MG3	650	1.0	±150	TA7303P,TA7130,μPC1028H,LA1150
JT10.7MG16	60~90	0.9	300	TA8122AN
JT10.7MG18	60~90	0.9	300	TA8132N
JT10.7MG33	45	0.7	250	TA2007
JT10.7MG80	65	1.0	300	TA2104AFN
JT10.7MG82	90	0.8	320	TA2099N
JT10.7MG92	60	1.0	300	TA2132P
JT10.7MC1	35	1.0	242	CXA1019M,CX-20091

▶ Ceramic Discriminator JT10.7M Series For FM Dimensions

JT10.7M Series For FM Standard Rule

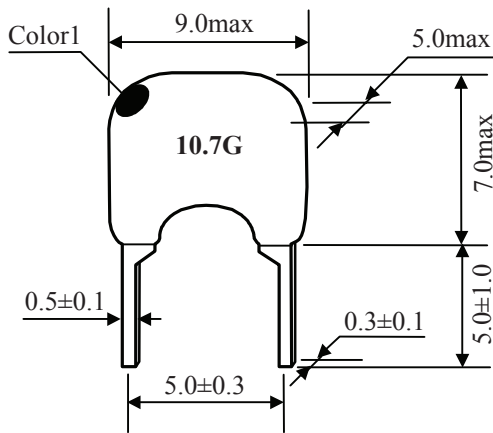

Center Frequency	Color
D:10.64MHz±30kHz	Black
B:10.67MHz±30kHz	Blue
A:10.70MHz±30kHz	Red
C:10.73MHz±30kHz	Orange
E:10.76MHz±30kHz	White

▶ Ceramic Discriminators - JT10.7M Series For FM Test Circuit

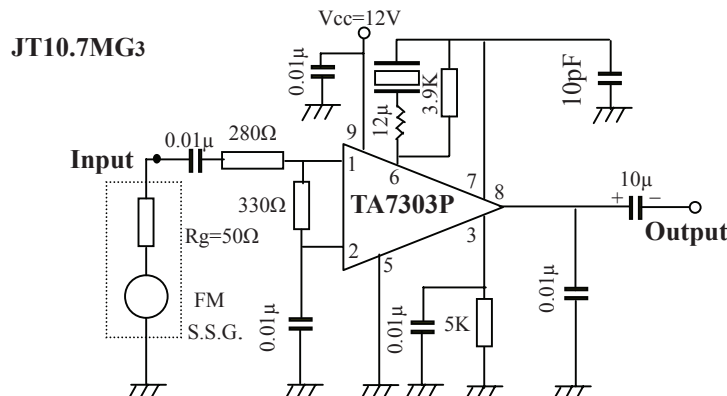



Discriminator

► Ceramic Discriminator JT10.7M Series For FM Test Circuit

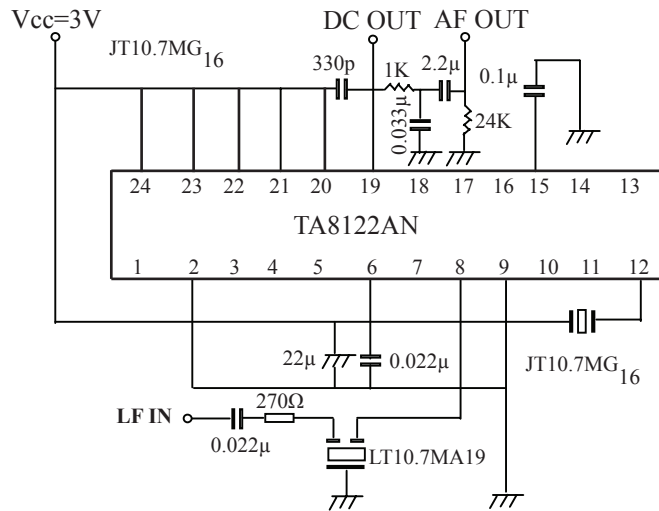

► How to Order

JT10.7MG3 - A P
① ② ③

- ① Part Number
- ② Center Frequency color code
- ③ Packaging



Discriminator

Ceramic Discriminators for Communication - JTM Series

▶ JTM for Communication (Murata CDB/CDBC/CDBM Compatible)

455kHz

Ceramic Discriminators - JTM For Communication consists of wide band piezoelectric resonator. It is ideal for mobile communication equipment due to its small size and light weight. Standard line includes products for a wide range of applications, from cordless telephones to cellular telephones, making non-adjustment and shrinking of the detection circuit possible. Token JTM including features with small in size and lightweight, realize non-adjustment in detection circuit, high sensitivity and stability, wide range of standard products are available for various ICs, operating temperature range:-20°C to +80°C and storage temperature range:-40°C to +85°C.

▶ Ceramic Discriminator JTM Series for Communication Technical Characteristics

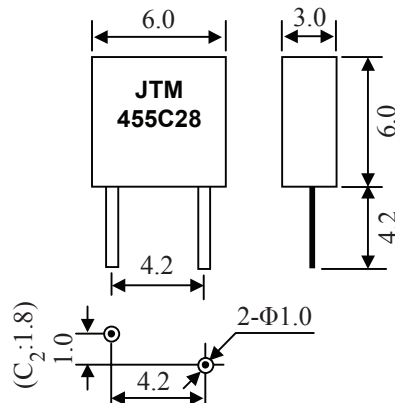

Part Number	Center Frequency (fo)(kHz)	Recovered Audio 3dB BW (kHz)min	Recovered Audio Output (mV)min	Distortion Factor (At fo) (%)max	Applicable IC
JTM455C18	455±2	±3.0	180±40	2.0	MC3371
JTM455C24	455±2	±4.0	100±40	2.0	TA31136
JTM455C28	455±2	±4.0	40±20	3.0	TA31142
JTM455C29	455±2	±4.0	125±30	2.5	NE605
JTM455C32	455±2	±4.0	40±20	3.0	TA31143
JTM455C47	455±2	-	140±20(fo) 140±20 (fo±4.8)	-	TA31147
JTM455C50	455±2	±4.0	64±6.4	4.0	CXA3117N

Part Number	Resonant Frequency (Fr)(kHz)	Antiresonant Frequency (Fa)(kHz)	Band Width Fa-Fr(kHz)	Resonant Resistance (Ω)max	Capacitance pF±20%	ApplicableIC
JTM455C2	447.5±1.5 (at Z =2.05kΩ)	463.0±1.5 (at Z =10kΩ)			140	TA8104
JTM455C3		455.0±1.5	48.0±5.0	70	600	CXA1184M
JTM455C4		470.0±1.0	43.0±2.0	300	140	LA8610
JTM455C10	429.0±2.0		51.0±5.0	70	580	TA8103F
JTM455C15		463.5±1.0	43.0±2.0	300	140	CXA1483M
JTM455C25		465.0±1.5	45.0±4.0	300	135	CXA1484

▶ How to Order



① Part Number ② Packaging





Discriminator

Ceramic Discriminators for Communication - JTC Series

▶ JTC for Communication (Murata CDBC Compatible)

455kHz

Ceramic Discriminator JTC consists of wide band piezoelectric resonator. It is ideal for mobile communication equipments due to its small size and light weight. Standard line include products for wide range of application, from cordless telecom to cellular telephone, making non-adjustment and shrinking of the detection circuit possible.

▶ Discriminator Features

1. Small in size and light weight.
2. Realize no-adjustment in detection circuit.
3. High sensitivity and stability.
4. Wide range of standard products are available for various ICs.
5. Operating temperature range: -20 to +80 (°C)
Storage temperature range: -40 to +85 (°C)

▶ Ceramic Discriminator JTC Series for Communication Technical Characteristics

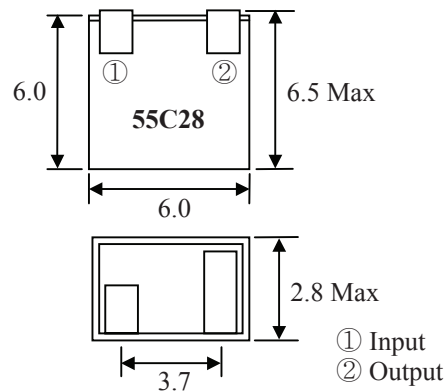

Part Number	Center Frequency (fo)(kHz)	Recovered Audio 3dB BW (kHz)min	Recovered Audio Output (mV)min	Distortion Factor (At fo) (%)max	Applicable IC
JTC455C24	455±2	±4.0	100±40	2.0	TA31136
JTC455C28	455±2	±4.0	40±20	3.0	TA31142
JTC455C29	455±2	±4.0	125±30	2.5	NE605
JTC455C32	455±2	±4.0	40±20	3.0	TA31143
JTC455C49	455±2	±4.0	45±20	3.0	MC3361
JTC455C50	455±2	±4.0	65±20	4.0	CXA3117N

▶ How to Order



① Part Number

② Packaging (T: Taping Reel)



Discriminator

Chip Ceramic Discriminators for FM - JTCV10.7M Series

Chip Ceramic Discriminators JTCV10.7M for FM are resonated devices that offer adjustment free audio detection in both wide and narrow bandwidths. These IC dependent devices utilize FM specific detection methods to convert changes in frequency into an intelligible audio signal.

Features

1. Small in size and light weight.
2. High sensitivity and stability.
3. Wide range of standard products are available for various ICs.
4. Operating temperature range: $-20 \sim +80 \text{ }^\circ\text{C}$
Storage temperature range: $-40 \sim +85 \text{ }^\circ\text{C}$

JTCV10.7M for FM receiver

10.7MHz

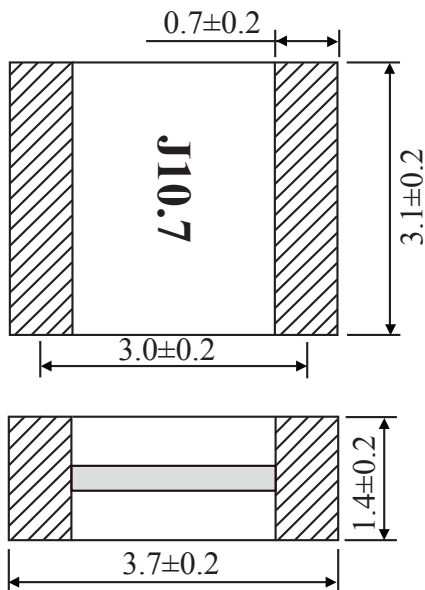

JTCV10.7M Series for FM Technical Characteristics				
Part Number	Demodulation Output at f_0 (mv) min	Distortion Factor at f_0 (%) max	Demodulation 3dB Band Width (KHz) max	Applicable IC
JTCV10.7MG1	25	1.0	345	CX-2009, CX-20111
JTCV10.7MG3	650	1.0	± 150	TA7303P, TA7130, μ PC1028H, LA1150
JTCV10.7MG16	60~90	0.9	300	TA8122AN
JTCV10.7MG18	60~90	0.9	300	TA8132N
JTCV10.7MG33	45	0.7	250	TA2007
JTCV10.7MG80	65	1.0	300	TA2104AFN
JTCV10.7MG82	90	0.8	320	TA2099N
JTCV10.7MG92	60	1.0	300	TA2132P
JTCV10.7MC1	35	1.0	242	CXA1019M, CX-20091

Chip Ceramic Discriminators JTCV10.7M Series For FM Test Circuit

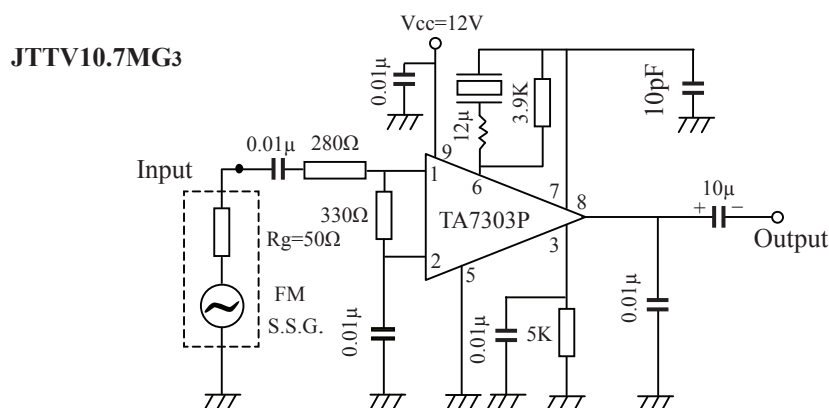



Discriminator

► Chip Ceramic Discriminators JTCV10.7M Series For FM Test Circuit

JTCV10.7MG₁₆

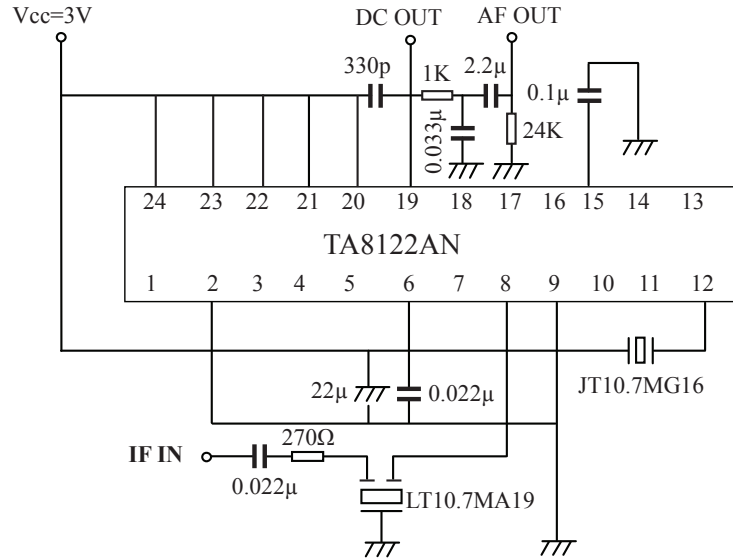

JTCV 10.7MG₁₈

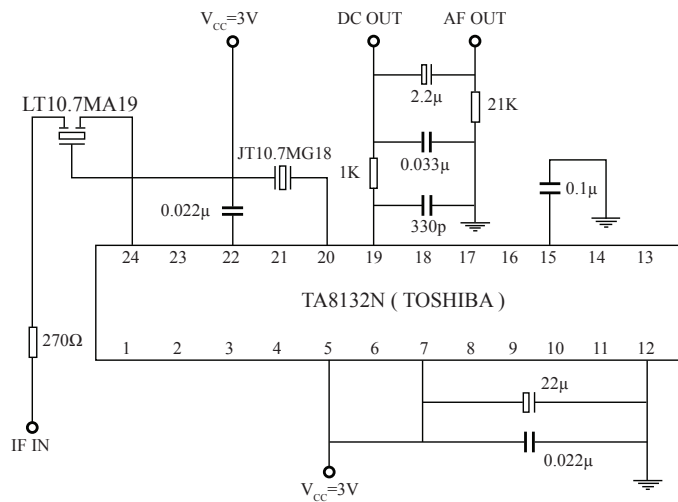

JTCV 10.7MC₁

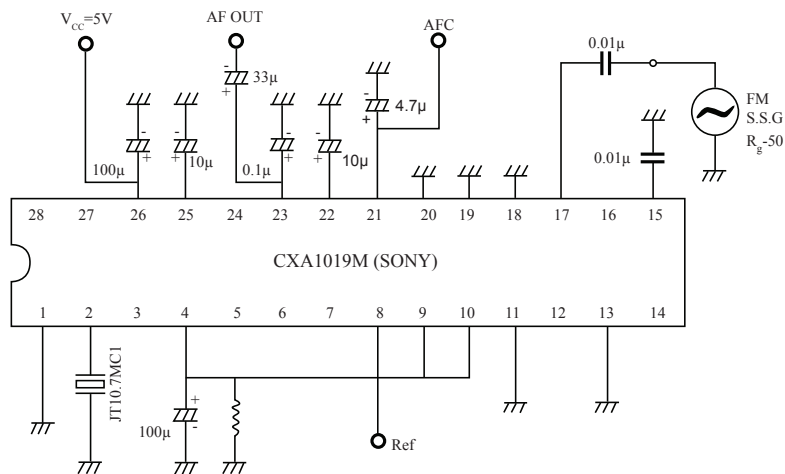

► How to Order

JTCV10.7MG3

①

T

②

① Part Number

② Packaging (T: Taping Reel)



Ceramic Trap

Ceramic Trap Filter for Chrominance Carrier XT MJ/MB Series

Ceramic Trap Filter XT MJ/MB Series are band reject device used for video and sound IF attenuation. The 2 terminal XT MJ Series can be used to attenuate either the sound signal in B/W receivers or the chroma signal in video.

▶ XT MJ for Chrominance Carrier (Murata TPS MJ Series Compatible) 3.58 MHz ~ 6.5 MHz

Ceramic Trap Filter XT MJ Series Technical Characteristics

Part Number	Center Frequency (fo1)(MHz)	Attenuation (at fo1)(dB)min	20dB Attenuation BW (fo1)(kHz)min
XT3.58MJ	3.580	20	20
XT4.43MJ	4.430	20	40
XT4.5MJ	4.500	20	40
XT5.5MJ	5.500	20	40
XT5.74MJ	5.742	20	40
XT6.0MJ	6.000	20	40
XT6.5MJ	6.500	20	40

Note : The level at 1MHz shall be made for a reference (0dB).

▶ Ceramic Trap Filter XT MJ Series Dimensions

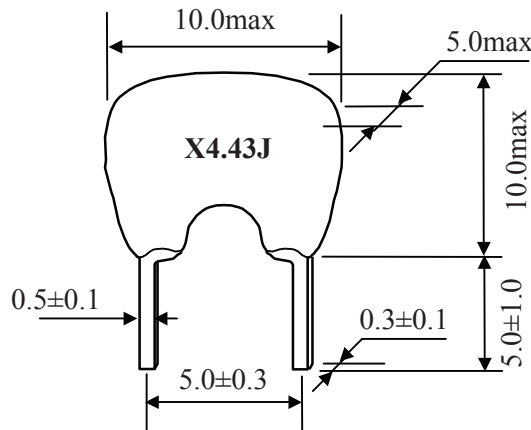

▶ Ceramic Trap Filters - XT MJ Series Test Circuit

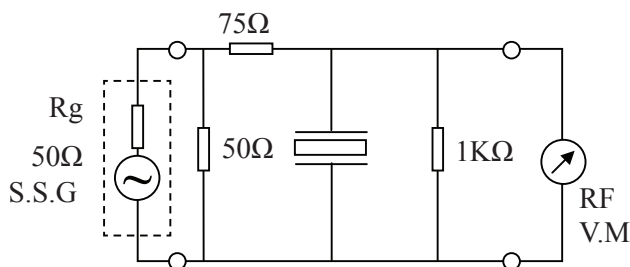

XT MJ Series Characteristics

XT4.5MJ

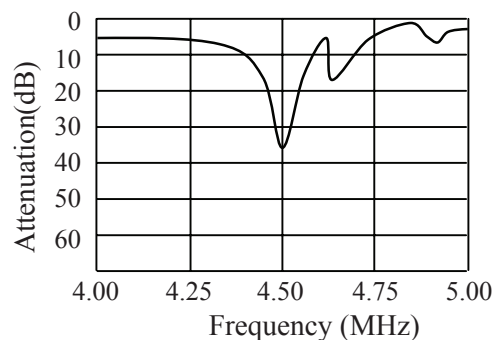

▶ How to Order



① Part Number

② Packaging



Ceramic Trap

Trap Filters Double Type - XT MW Series

Token XT MW Series consist of 2 wafers with 2 trap frequencies. Recommended for Multi standard set. Features with good performance of attenuation and space saving with 3-terminal type.

▶ XT MW Series (Murata TPWA Series Compatible)

4.5 MHz ~ 6.5 MHz

Trap Filters Double Type - XT MW Series Technical Characteristics

Part Number	CenterFrequency (fo1)(MHz)	CenterFrequency (fo2)(MHz)	Attenuation(at fo1)(dB)min	Attenuation(at fo2)(dB)min	30dBAttenuation BW(fo1)(kHz)min
XT4.47MW	4.500	4.724	30	30	50
XT4.60MW	4.500	6.000	30	30	50
XT5.57MW	5.500	5.742	30	30	50
XT5.60MW	5.500	6.000	30	30	50
XT5.65MW	5.500	6.500	30	30	50
XT6.65MW	6.000	6.500	30	30	70

Note : The level at 1MHz shall be made for a reference(0dB).

▶ Trap Filters Double Type XT MW Series Dimensions

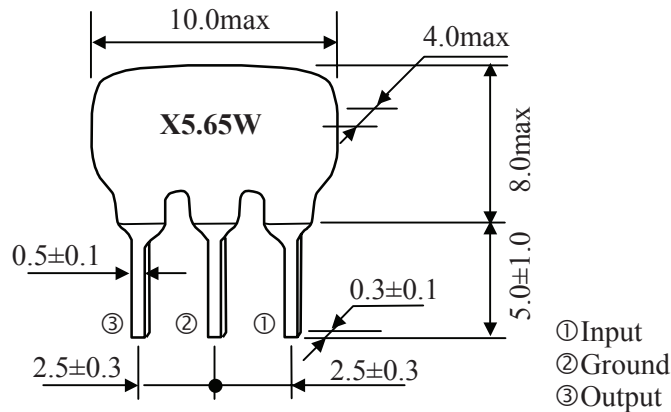

▶ XT MW Series Test Circuit

XT MW TEST CIRCUIT

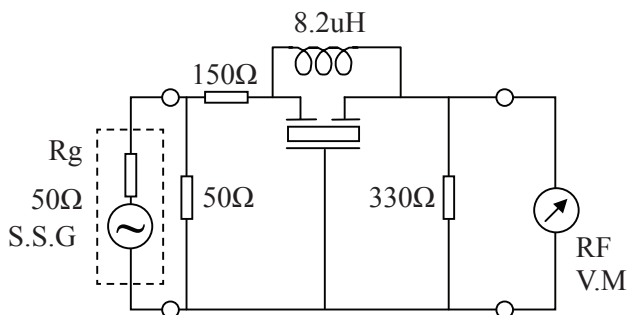

XT MW Series Characteristics

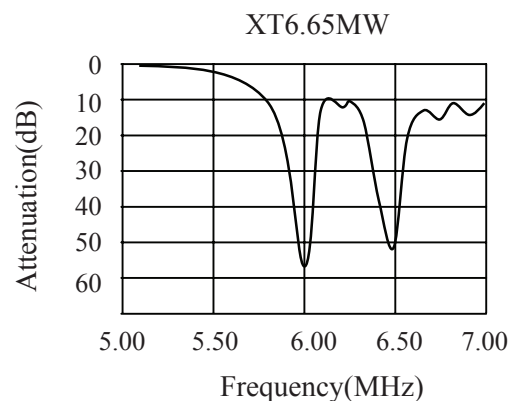

▶ How to Order



- ① Part Number
- ② Packaging



Ceramic Trap

Trap Filters for TV/VCR Stage - XT MB Series

XT MB Series are band reject type used for video and sound IF attenuation. The 3 terminal XT MB Series contains 2 elements on one substrate for additional attenuation. XT MB Series can be used in the sound IF of CATV/VCR receivers.

▶ XT MB for TV/VCR Stage (Murata TPS MB Series Compatible)

3.58 MHz ~ 6.5 MHz

Trap Filter XT MB Series Technical Characteristics

Part Number	Center Frequency (fo1)(MHz)	Attenuation (at fo1)(dB)min	30dB Attenuation BW (fo1)(kHz)min
XT3.58MB	3.580	25	40(25dB Att.BW)
XT4.43MB	4.430	30	50
XT4.5MB	4.500	35	70
XT5.5MB	5.500	35	90
XT5.74MB	5.742	35	90
XT6.0MB	6.000	35	90
XT6.5MB	6.500	35	90

Note: The level at 1MHz shall be made for a reference (0dB).

▶ Trap Filter XT MB SERIES DIMENSIONS

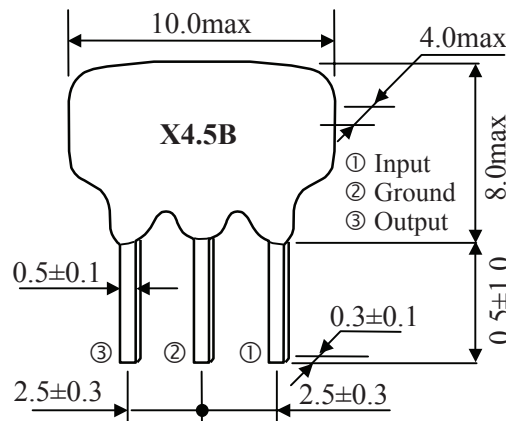

▶ Trap Filters - XT MB Series Test Circuit

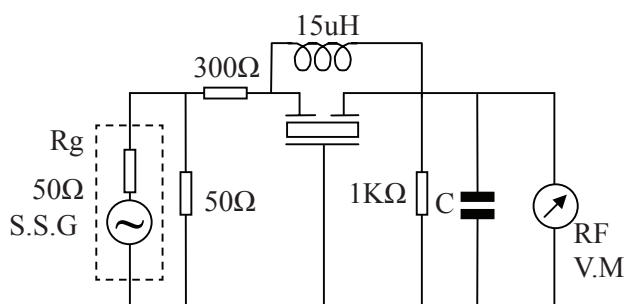

XT MB Series Characteristics

XT4.5MB

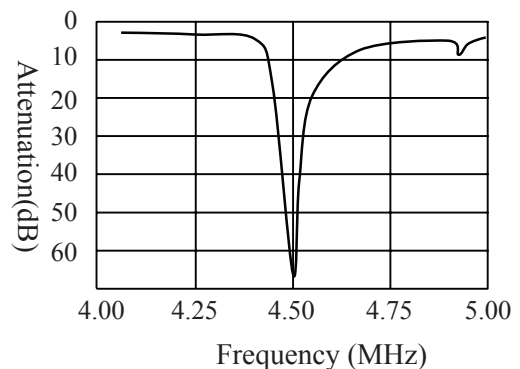

▶ How to Order



① Part Number

② Packaging



Ceramic Trap

Triple Trap Filters - XT MT Series

Token XT MT Ceramic trap (compatible to Murata TPT) series consist of 3 wafers with 3 trap frequencies. Recommended for Multi standard sets.

▶ Triple Trap Filter Features

1. Good performance of attenuation
2. Space saving for Multi set
3. Three-terminals type

▶ XT MT Series (Murata TPT Series Compatible)

4.5 MHz ~ 6.5 MHz

Triple Trap Filter XT MT Series Technical Characteristics

Part Number	Center Frequency (fo1)(MHz)	Center Frequency (fo2)(MHz)	Center Frequency (fo3)(MHz)	Attenuation (at fo1) (dB)min	Attenuation (at fo2) (dB)min	Attenuation (at fo3) (dB)min	30dB Attenuation BW (fo1)(kHz)min
XT01MT	5.500	6.000	6.500	30	30	30	50
XT02MT	5.500	5.742	6.500	30	30	30	50
XT03MT	5.500	5.742	6.000	30	30	30	50

•The level at 1MHz shall be made for a reference (0dB).

▶ XT MT Series Dimensions

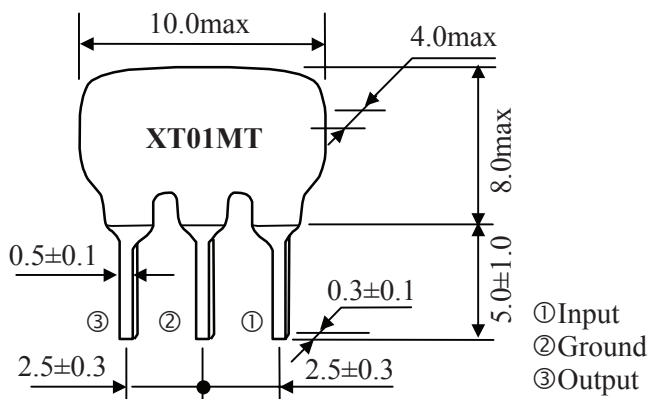

XT MT Series Test Circuit

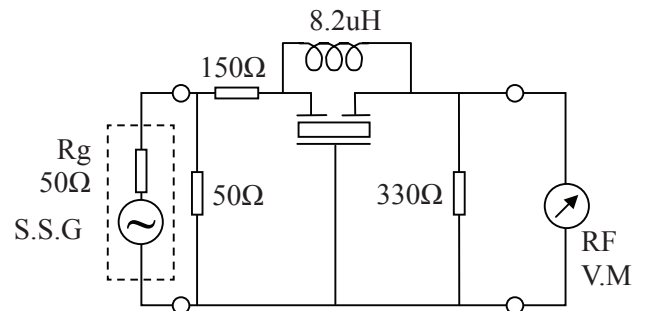

▶ How to Order



- ① Part Number
- ② Packaging



Piezoceramics component

Radial Taping Dimensions of Resonators and Filters

► Radial Taping Dimensions

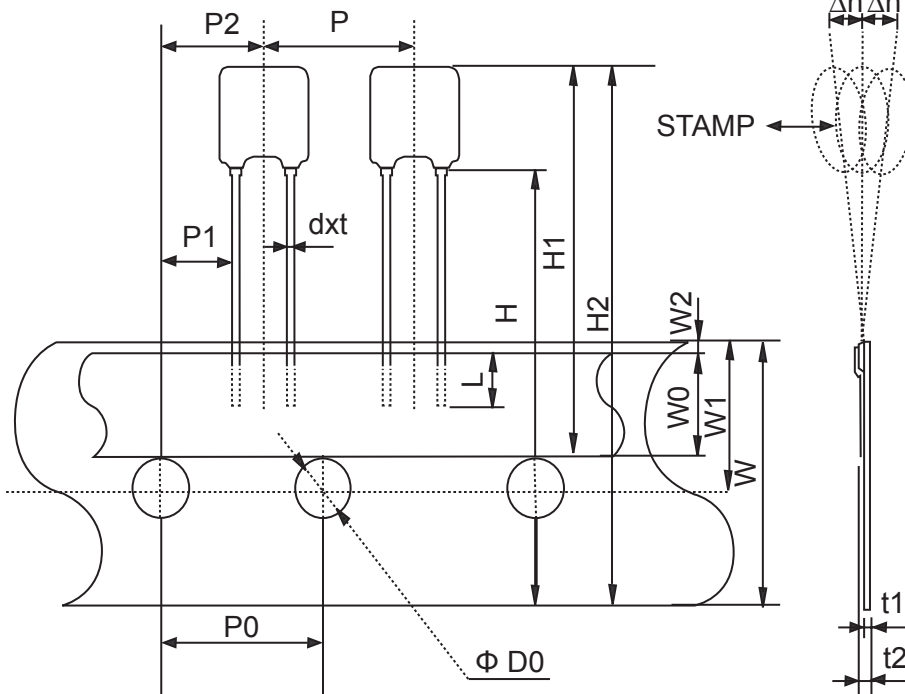

Mark	Size(mm)
P	12.7±0.5
P0	12.7±0.2
P1	3.85±0.5
P2	6.35±1.3*
F	0.5 ^{+0.5} _{-0.3}
dxt	0.5x0.3(±0.1)
W	18.0±0.5
W0	5.5±0.5
W1	9.0±0.5
W2	1.0max
H	18.0 ^{+0.5} _{-1.0}
H1	27.0max**
H2	36.0max**
L	3.0main
ΦD0	4.0±0.2
t1	0.6±0.2
t2	1.5max
Δh	1.0max

*Include the slant of products

**Varies with part number

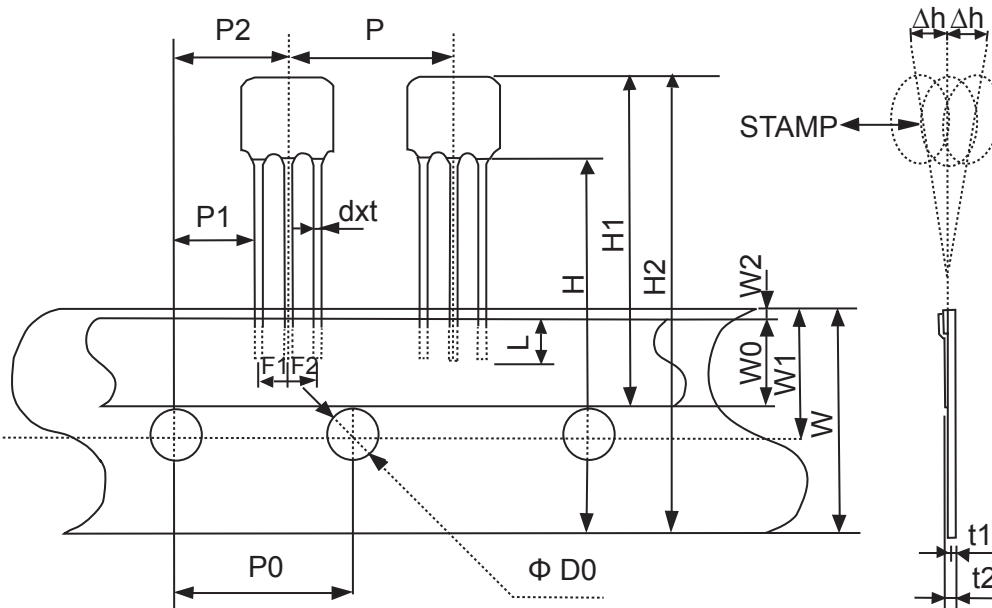

Mark	Size(mm)
P	12.7±0.5
P0	12.7±0.2
P1	3.85±0.5
P2	6.35±1.3*
F	0.5 ^{+0.5} _{-0.3}
dxt	0.5x0.3(±0.1)
W	18.0±0.5
W0	5.5±0.5
W1	9.0±0.5
W2	1.0max
H	18.0 ^{+0.5} _{-1.0}
H1	27.0max**
H2	36.0max**
L	3.0main
ΦD0	4.0±0.2
t1	0.6±0.2
t2	1.5max
Δh	1.0max



Piezoceramics component

► Packing Method

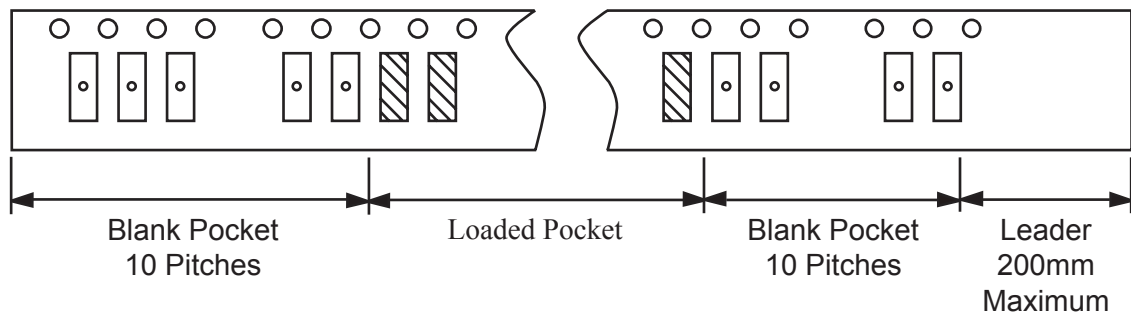

► Reel Dimensions (mm)

ΦA	ΦB	W	T	Pieces per reel	Carrier tape size
179±2	60 typ	8.4 min	14.0max	3000typ	8
179±2	60 typ	12.4 min	19.4max	3000typ	12
179±2	60 typ	12.4 min	19.4max	1000typ	12
179±2	60 typ	16.4 min	22.4max	1000typ	16
330±3	80 min	12.4 min	19.4max	4000typ	12
330±3	80 min	16.4 min	22.4max	4000typ	16

► Reel

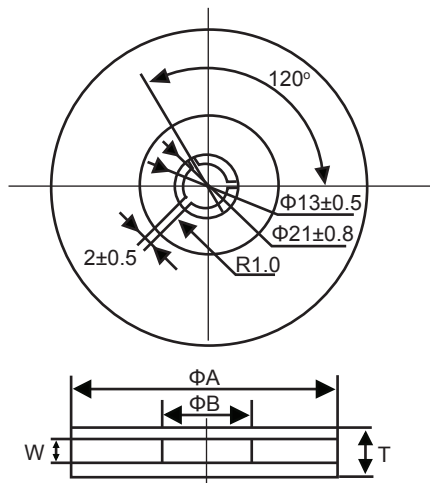

Tape

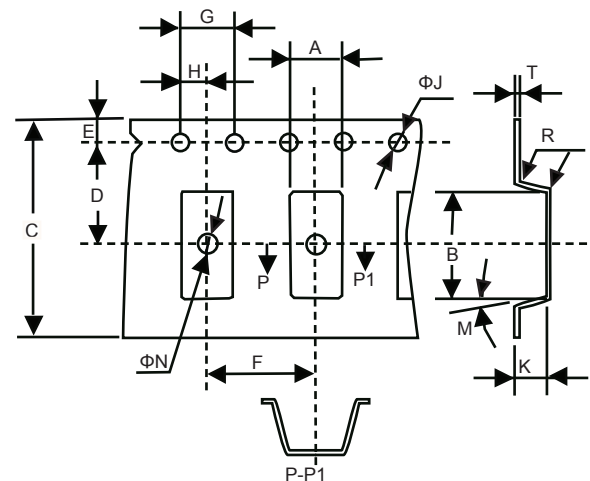

► Tape Dimensions (mm)

Part Number	Code	A	B	C	D	E	F	G	H	ΦJ	ΦN	M	R	K	T
	Tolerance	±0.2	±0.2	±0.3	±0.1	±0.1	±0.1	±0.1	±0.1	±0.1	±0.1	max	max	±0.2	±0.1
ZTACC MG ZTTCC MG		3.8	7.8	16.0	7.5	1.75	8.0	4.0	2.0	1.5	1.6	10°	0.3	2.1	0.3
ZTACR MG ZTTCR MG		2.2	4.7	12.0	5.5	1.75	4.0	4.0	2.0	1.6	1.6	3°	0.3	1.3	0.3
ZTACS MT/MX ZTTCS MT/MX		5.0	4.4	12.0	5.5	1.75	8.0	4.0	2.0	1.5	1.6	10°	0.3	1.8	0.3
ZTACV MT/MX ZTTCV MT/MX		3.4	4.0	12.0	5.5	1.75	8.0	4.0	2.0	1.5	1.6	10°	0.3	1.3	0.3
ZTACW MX ZTTCW MX		2.2	2.8	8.0	3.5	1.75	4.0	4.0	2.0	1.6	1.1	3°	0.3	1.3	0.2



Piezoceramics component

► Test Condition of Peeling Strength

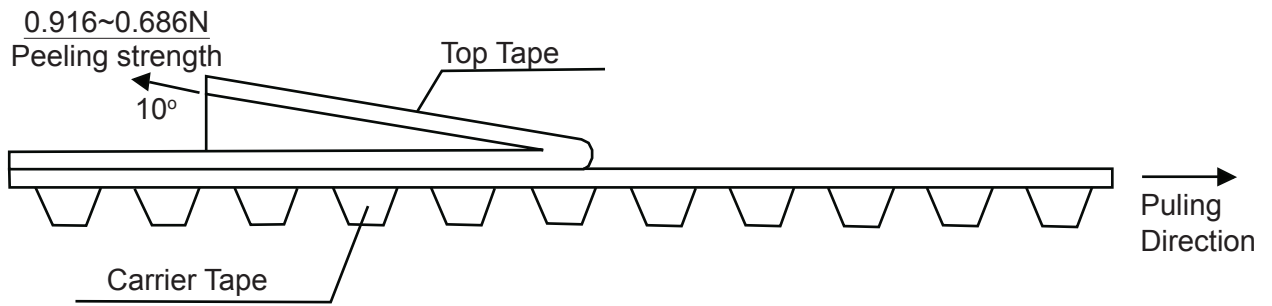

► Recommended Reflow Soldering Standard Conditions

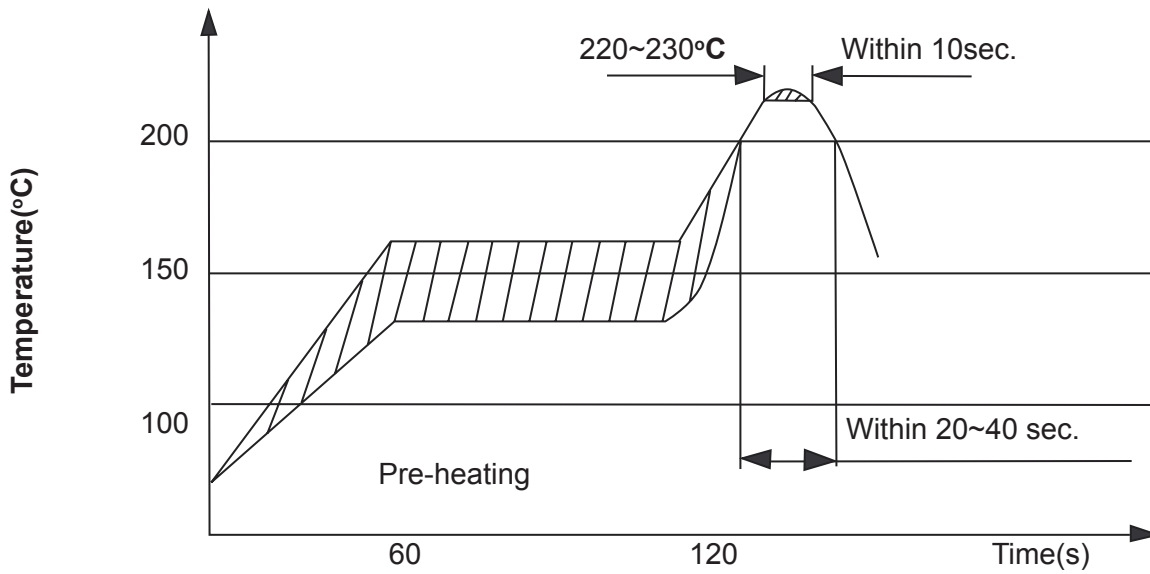



Piezoceramics component

PIEZO DIELECTRIC MICROWAVE DEVICES - PRECAUTION USAGE

▶ GENERAL INFORMATION

Piezo dielectric microwave device that is used with the clock circuit of an IC to set the speed of the IC. The piezo by itself is not a clock, so it must be used with circuitry built into the IC to create the clock signal. Quartz crystals have been used in this manner for many years, but TOKEN offers lower cost and more rugged piezo products in piezo dielectric microwave, ceramic resonators, ceramic filters, and . The clock circuit consists of the passive resonator, quartz or ceramic piezo, and an active amplifier that is built into the IC.

▶ PIEZO DEVICES CHARACTERISTICS PRECAUTIONS FOR SAFETY

In application of the piezo devices, it is recommended that equipment shall be protected by adding a protective and/or retardant design circuit against deteriorations and failures of the ceramic piezo.

▶ OPERATION TEMPERATURE RANGES

The ceramic piezo devices shall not be operated beyond the specified “Operating Temperature Range” in the Specifications.

▶ CHANGES / DRIFTS IN OSCILLATING

It shall be noted that oscillating frequencies of the ceramic piezo devices may drift depending on different IC manufacturer applied and capacitance values of external capacitors and the circuit design.

▶ ABNORMAL OSCILLATION

The ceramic piezo device is always accompanied by spurious resonances. Hence in the circuit, spurious oscillations or stop of oscillation may occur depending on the circuit design (IC applied, frequency characteristics of the IC, supply voltage etc.) and/or environmental conditions Attention shall be paid to those abnormalities above mentioned in circuit design.

▶ STRAY CAPACITANCE

Stray capacitance and insulation resistances on printed circuit board may cause abnormalities of the ceramic piezo device such as “higher harmonic oscillations”. or “stop of oscillations”. Attention shall be paid to those abnormalities above mentioned in circuit design.

▶ OVERVOLTAGE SPIKES AND ELECTROSTATIC DISCHARGES

Abnormal/excess electrical stresses such as over voltage spikes and electrostatic discharges may cause electrical deteriorations and failures of the ceramic piezo and affect reliability of the devices.

▶ ABNORMAL MECHANICAL STRESS

Abnormal/excess mechanical stresses such as falling shocks shall not be applied to the ceramic piezo devices in handling, to prevent them from being damaged or cracked. Dropped devices shall not be used.

▶ SURFACE MOUNTING CONSIDERATION

In automated mounting of the chip ceramic piezo device on printed circuit boards, any bending, expanding and pulling forces or shocks against the chip ceramic piezo devices shall be kept minimum to prevent them from electrical failures and mechanical damages of the devices.

▶ SOLDERING FLUX

1. Rosin-based and non-activated soldering flux is recommended.
2. The content of halogen in the flux shall be 0.1 wt. % or less.

Note: In case of water-soluble type or activated type soldering flux being applied, the flux residues on the surface of PC boards, may have influences on the reliability of the ceramic piezo device, and cause deteriorations and failures of the devices.

▶ POST SOLDERING CLEANING

Application of ultrasonic cleaning is prohibited. Cleaning conditions such as kinds of cleaning solvents, immersion time and temperatures etc. shall be checked by experiments before production.





Ceramic Filters

► SOLDERING (REFLOW)

Solderings of the chip ceramic piezo devices shall conform to the soldering conditions in the individual specifications. The chip ceramic piezo devices are designed for “Reflow Solderings” in the reflow solderings, too high Soldering temperatures and too large temperature gradient such as rapid heating or cooling may cause electrical failures and mechanical damages of the devices.

Following soldering conditions are recommended;

Preheating: 150 degree C for 60 sec to 120 sec.

Soldering Temperature: 220 degree C for 10 seconds max.

Peak Soldering Temperature: 240 degree C max.

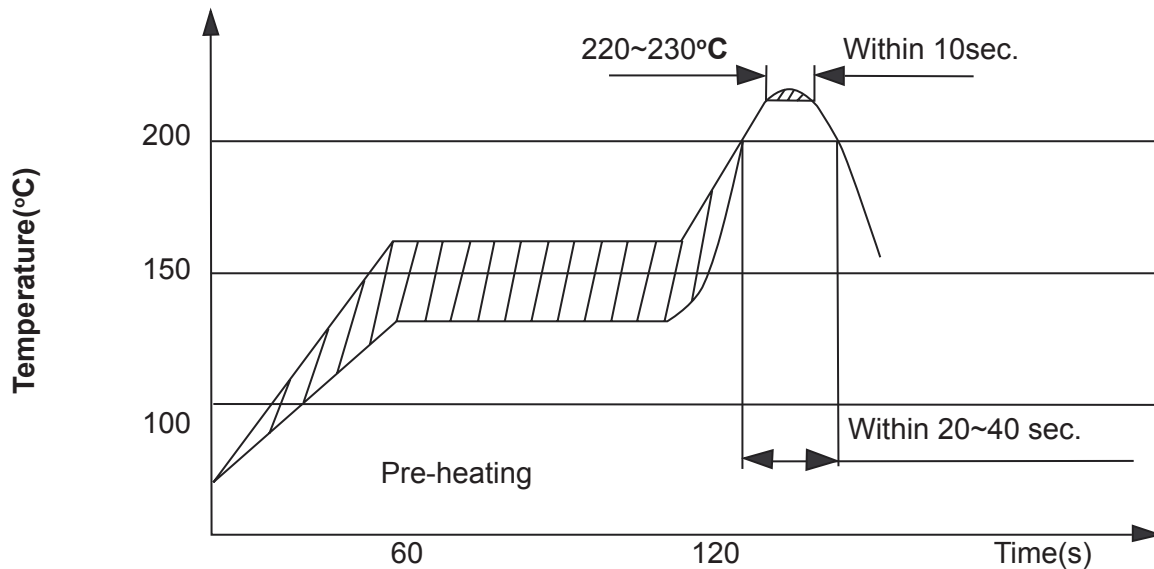

► OPERATION AND STORAGE CONDITIONS

The ceramic piezo devices shall not be operated and/or stored under following environmental conditions:

To be exposed directly to water or salt water.

To be exposed directly to sunlight.

Under conditions of dew formation.

Under conditions of corrosive atmosphere such as hydrogen sulfide, sulfurous acid, chlorine and ammonia.