

PCB 继电器	TRG1
----------------	-------------

- 5A switching capability
- SPST-NO configuration
- Standard PC layout
- Sealed type available
- Surge resistance of 5000V
- Conform to RoHS,ELV directive

07001021631

us E173485

R50108695

外形尺寸 18.2×10.2×15.2

ORDERING CODE 订购代码

<u>TRG1</u> <u>D</u> — <u>12VDC</u> — <u>S</u> — <u>H</u> 1 2 3 4 5		
<table style="width: 100%; border: none;"> <tr> <td style="width: 50%; vertical-align: top; border: none;"> 1. Relay Model 继电器型号 2. Coil Power 线圈功率 D=0.45W, L=0.2W 3. Coil Nominal Voltage 线圈额定电压 3,5,6,9,12,18,24VDC </td> <td style="width: 50%; vertical-align: top; border: none;"> 4. 封装形式: Sealed 密封 5. 触点转换形式 H: Form A </td> </tr> </table>	1. Relay Model 继电器型号 2. Coil Power 线圈功率 D=0.45W, L=0.2W 3. Coil Nominal Voltage 线圈额定电压 3,5,6,9,12,18,24VDC	4. 封装形式: Sealed 密封 5. 触点转换形式 H: Form A
1. Relay Model 继电器型号 2. Coil Power 线圈功率 D=0.45W, L=0.2W 3. Coil Nominal Voltage 线圈额定电压 3,5,6,9,12,18,24VDC	4. 封装形式: Sealed 密封 5. 触点转换形式 H: Form A	

COIL DATA 线圈参数 (at 20°C)

Nominal Voltage额定电压(VDC)	3	5	6	9	12	18	24	0.2W
Coil Resistance线圈阻值($\Omega \pm 10\%$)	45	125	180	405	720	1620	2880	
Rated Current额定电流(mA)	66.67	40	33.33	22.22	16.67	11.11	8.33	
Max Operate Voltage 最大吸合电压(VDC)	2.25	3.75	4.5	6.75	9	13.5	18	
Min Release Voltage最小释放电压(VDC)	0.15	0.25	0.3	0.45	0.6	0.9	1.2	0.45W
Coil Resistance线圈阻值($\Omega \pm 10\%$)	20	56	80	180	320	720	1280	
Rated Current额定电流(mA)	150	89.28	75	50	37.5	25	18.75	
Max Operate Voltage 最大吸合电压(VDC)	2.25	3.75	4.5	6.75	9	13.5	18	
Min Release Voltage最小释放电压(VDC)	0.15	0.25	0.3	0.45	0.6	0.9	1.2	
Max Applicable Voltage 最大过载电压	70°C时额定电压的 130%, 23°C时额定电压的 170%							

CONTACT DATA 触点参数

Contact Form触点形式	1H
Contact Material触点材料	Silver Alloy
Load负载	Resistive load(COS Φ 1)
Contact Ratings触点负载	1H-D: 10A 125VAC 5A 250VAC/30VDC 1H-L: 3A 250VAC/30VDC
Minimum load 最小负载	100mA 5VDC
Max Switching Voltage最大转换电压	277VAC/30VDC
Max Switching Current最大转换电流	1H-D:5A 1H-L:3A
Max Switching Power 最大转换功率	1H-D:1200VA/150W 1H-L: 600VA/90W
Contact Resistance接触电阻	100m Ω Max at 6VDC 1A
Life Expectancy寿命	Electrical 电气寿命: 100,000 Operations(at30Operations/minute)
	Mechanical机械寿命: 10,000,000 Operations(at3000Operations/minute)

■ CHARACTERISTICS DATA 性能参数

Insulation Resistance绝缘阻值	100MΩ Min at 500VDC
Dielectric Strength Between Open Contacts触点间耐压	1000VAC(for one minute)
Between Contacts and coil触点与线圈间耐压	4000VAC(for one minute)
Operate Time吸合时间	1H-D:10ms 1H-L: 15ms
Release Time释放时间	4ms
Temperature Range环境温度	-40°C to +85°C
Shock Resistance冲击	Operating Extremes动作极限: 10G
	Damage Limits破坏极限: 100G
Vibration Resistance振动	10-55Hz, 1.5mm双振幅
Max. switching frequency最大转换频率	Mechanical: 18,000operations/hr
	Electrical: 1,800operations/hr
Humidity湿度	40-85%
Weight重量	Approx 6g
Safety Standard安全标准	UL cUL TÜV CQC

■ APPROVED STANDARDS 安全标准

Model(型号)	Coiling rating (线圈电压)	Safety Standard (安全标准)	Contact rating (触点负载)	
TRG1	3 to 24VDC	UL	10A 120VAC 5A 240VAC 3A 240VAC 3A 30VDC	
		CQC	5A 240VAC	
		TÜV	1H-D	5A 250VAC 10A 125VAC 5A 30VDC
			1H-L	3A 250VAC 3A 30VDC

■ ENGINEERING DATA 设计参数

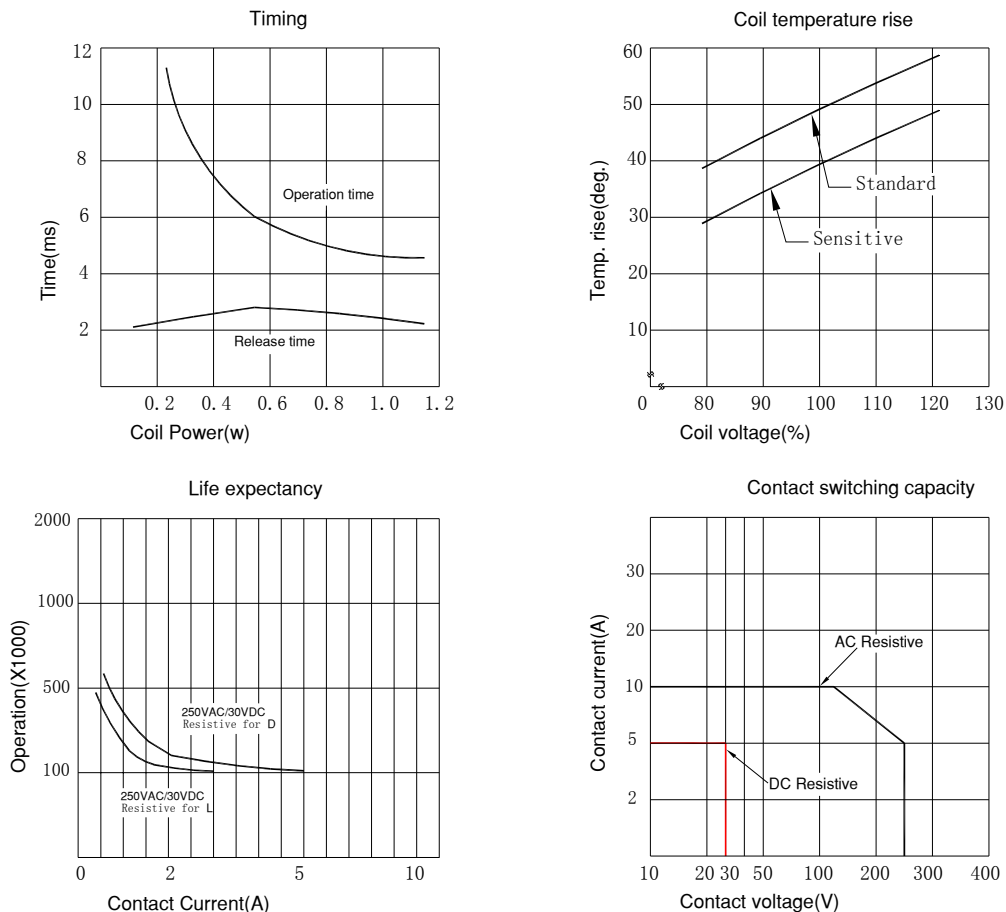

■ OVERALL AND MOUNTING DIMENSIONS 安装图

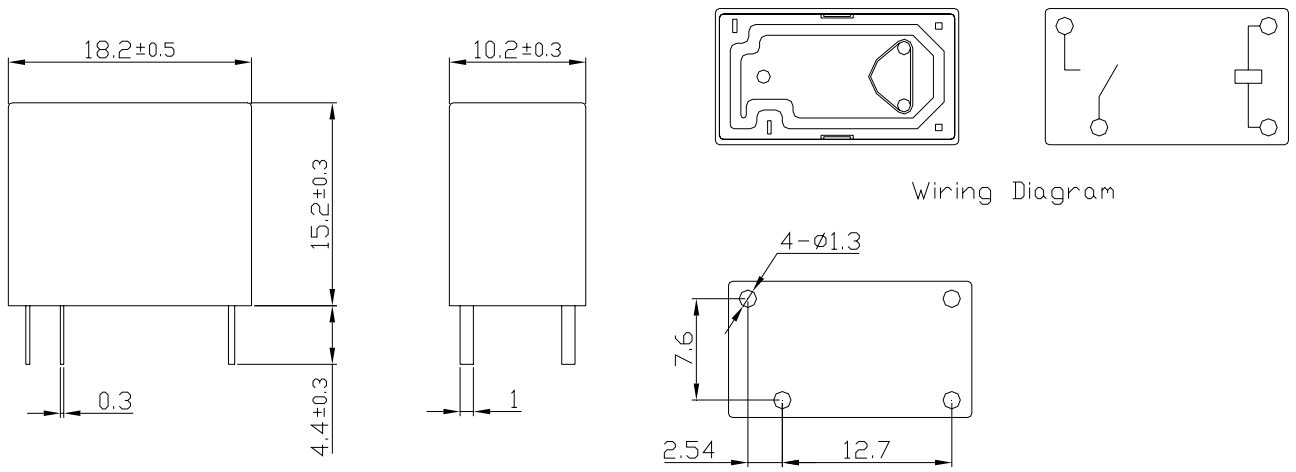

声明:

本产品规格书仅供客户使用时参考, 如有更改, 恕不另行通知。