

T-77-21

KA8401

LINEAR INTEGRATED CIRCUIT

**SWITCHLESS RECORDING/
PLAY BACK AMPLIFIER**

The KA8401 is a monolithic integrated circuit in a 16-lead zigzag in-line plastic package (shrink type). It consists of playback equalizer amplifier, recording/play back switch, line amplifier, ALC circuit with detector, recording amplifier and logic control circuit can control REC/EE and PB/EE line muting independently.

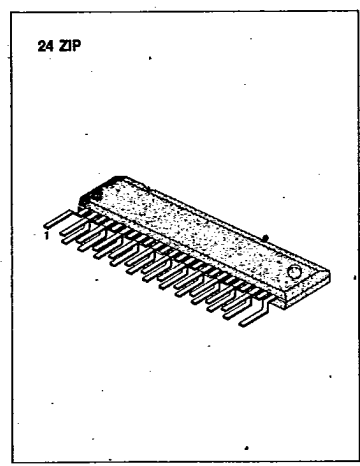

FUNCTIONS

- Play Back EQ Amp.
- Recording/Play Back S/W.
- Line Amp. & ALC Circuit with Detector.
- Recording Amp. & Logic Control Circuit.

FEATURES

- High level ALC V_R utilization provides a good S/N ratio & distortion factor
- The ALC level can be set according to the external resistance
- Extremely low POP noise during supply ON/OFF switching
- Extremely low shock noise during control system switching
- Few external parts required
- Wide operating supply voltage (4.5 ~ 12V)

BLOCK DIAGRAM

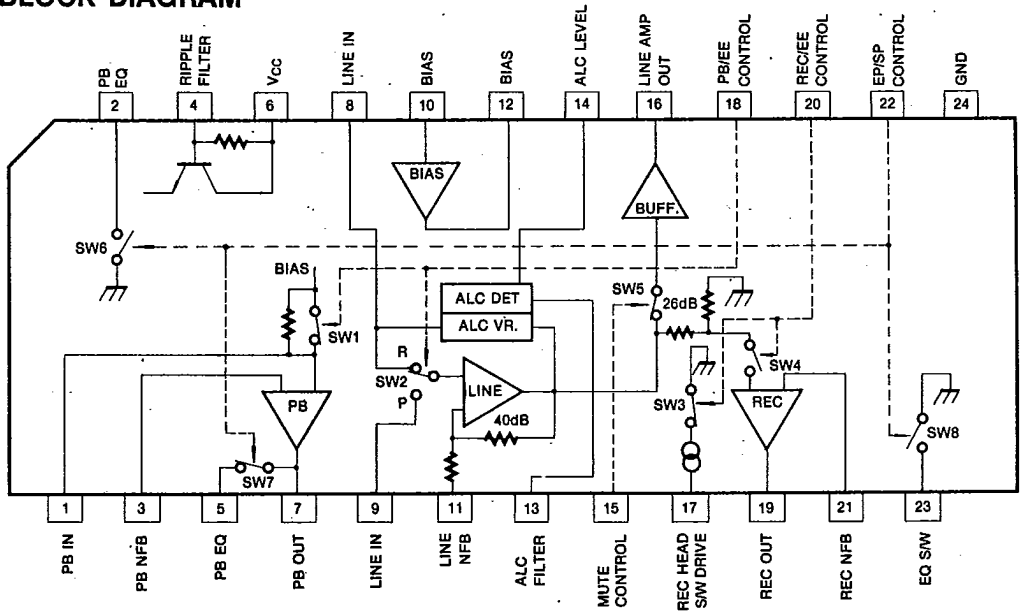

KA8401

LINEAR INTEGRATED CIRCUIT

ABSOLUTE MAXIMUM RATINGS (Ta = 25°C)

Characteristics	Symbol	Value	Unit
Maximum Supply Voltage	V _{CC}	13	V
Power Dissipation	P _D	400*	mW
Operating Temperature	T _{opr}	-10 ~ +65	°C
Storage Temperature	T _{stg}	-55 ~ +125	°C

Note: Derated above Ta = 25°C in the proportion of 4mW/°C

ELECTRICAL CHARACTERISTIC

(Ta = 25°C, V_{CC} = 5V, f = 1KHz, unless otherwise specified)

Characteristics	Symbol	Test Conditions	Min	Typ	Max	Unit
Supply Current	I _{CC1}	No Signal SP mode	—	5.0	9.2	mA
Supply Current	I _{CC2}	No Signal SP mode	—	8.0	14.1	mA

(Line Amp)

Recording Input Gain	G _{VEE}	V _{IN} = -25dBV, ALC OFF	15.0	16.7	18.4	dB
Total Harmonic Distortion	THD _{EE}	V _{IN} = -25dBV, ALC OFF	—	0.06	0.2	%
Residual Noise	V _{NOL}	R _G = 5.6KΩ	—	-76	-68	dBV
Input Impedance	Z _{INP}	P.B input	—	30	—	KΩ
Input Impedance	Z _{INR}	REC input	—	30	—	KΩ
Maximum Output Level	V _{OML}	THD = 1%	0.75	1.1	—	V _{rms}
ALC Level	V _{OA}	V _{IN} = -15dBV, ALC ON	0.47	0.58	0.71	V _{rms}
ALC Total Harmonic Distortion	THD _A	V _{IN} = -15dBV, ALC ON	—	0.06	0.2	%
ALC Distortion for Large Input	ΔTHD _A	V _{IN} = +10dBV, ALC ON	—	0.15	0.3	%

(REC AMP)

Overall Recording Gain	G _{VR}	V _{IN} = -25dBV, ALC OFF	16.3	18.0	19.7	dB
Open Loop Recording Gain	G _{VOR}	V _{IN} = -65dBV, ALC OFF	72	79	—	dB
Total Harmonic Distortion	THD _R	V _{IN} = -25dBV, ALC OFF	—	0.06	0.2	%
Maximum Recording Output	V _{OMR}	THD = 1%	0.85	1.2	—	V _{rms}

(PB EQ AMP)

Open Loop Playback Gain	G _{VOPB}	V _{IN} = -40dBV	64	71	—	dB
Total Harmonic Distortion	THD _{PB}	V _{IN} = -10dBV	—	0.02	0.15	%
PB EQ Input Noise	V _{NIPB}	R _G = 620Ω	—	-122	-114	dBV
Input Impedance	Z _{INPB}		—	120	—	KΩ
PB Overall Gain	G _{VP}	V _{IN} = -25dBV	74.3	78.5	82.7	dB

(PB/EE S/W MODE)

EE Mode Sustain Voltage	V _{18L}		0	—	0.8	V
PB Mode Sustain Voltage	V _{18H}		3.6	—	V _{CC}	V
Head S/W Impedance	Z _{SW1}		—	5	15	Ω

KA8401

LINEAR INTEGRATED CIRCUIT

ELECTRICAL CHARACTERISTIC (Continued)

Characteristics	Symbol	Test Conditions	Min	Typ	Max	Unit
(MUTE/MUTE S/W Mode)						
MUTE Mode Sustain Voltage	V _{15L}		0	—	1.5	V
MUTE Mode Sustain Voltage	V _{15H}		3.6	—	V _{CC}	V
MUTE Level	V _{MU}		—	-100	-60	dBV
(REC/EE S/W Mode)						
EE Mode Sustain Voltage	V _{20L}		0	—	1.7	V
REC Mode Sustain Voltage	V _{20H}		3.6	—	V _{CC}	V
Drive Sink Current	I _{SW17}		80	200	—	μA
(EQ S/W Mode)						
SP Mode Sustain Voltage	V _{22L}		0	—	1.0	V
EP Mode Sustain Voltage	V _{22H}		3.6	—	V _{CC}	V
SW2 Impedance	Z _{SW2}		—	6	30	Ω
SW5 Impedance	Z _{SW5}		—	12	60	Ω
SW23 Impedance	Z _{SW23}		—	6	30	Ω
(AFR S/W Mode)						
PB Mode Sustain Voltage	V _{20L}		0	—	0.5	V
REC Mode Sustain Voltage	V _{20H}		3.6	—	V _{CC}	V

TEST CIRCUIT

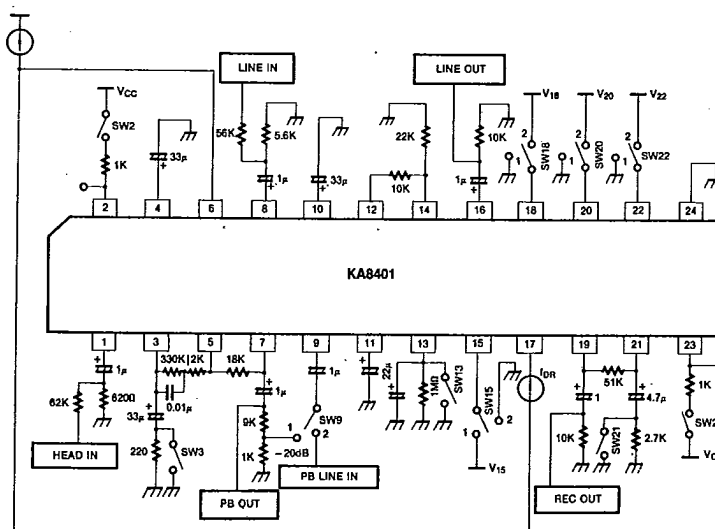

KA8401

LINEAR INTEGRATED CIRCUIT

CONTROL MODE TABLE

Mode	Control				SW								ALC
	REC/EE	PB/EE	MUTE	EP/SP	SW1	SW2	SW3	SW4	SW5	SW6	SW7	SW8	
EE	L	L	L	—	ON	R	ON	OFF	ON	—	—	—	ON
EE MUTE	L	L	H	—	ON	R	ON	OFF	OFF	—	—	—	ON
REC	H	L	L	—	ON	R	OFF	ON	ON	—	—	—	ON
REC MUTE	H	L	H	—	ON	R	OFF	ON	OFF	—	—	—	ON
PB	L	H	L	—	OFF	P	ON	OFF	ON	—	—	—	OFF
PB MUTE	L	H	H	—	OFF	P	ON	OFF	OFF	—	—	—	OFF
AFR	H	H	L	—	ON	R	OFF	ON	ON	—	—	—	ON
AFR MUTE	H	H	H	—	ON	R	OFF	ON	OFF	—	—	—	ON
EP	—	—	—	H	—	—	—	—	—	ON	OFF	ON	—
SP	—	—	—	L	—	—	—	—	—	OFF	ON	OFF	—

CONTROL MODE FUNCTION

Mode	Function
PB/EE Control	PB: High EE: Low REC/EE Input selection from line amp input ALC ON/OFF PB head switch ON/OFF
REC/EE Control	REC: High EE: Low REC amp output ON/OFF REC head switch ON/OFF (This mode is prior to PB/EE control mode and is able to correspond AFR mode)
MUTE Control	MUTE ON: High MUTE OFF: Low Line amp switch ON/OFF (ALC loop, this mode is able to control REC amp independantly)
EQ SW Control	EP: High SP: Low Each EQ switch/switch ON/OFF

T-77-21

KA8401

LINEAR INTEGRATED CIRCUIT

APPLICATION CIRCUIT

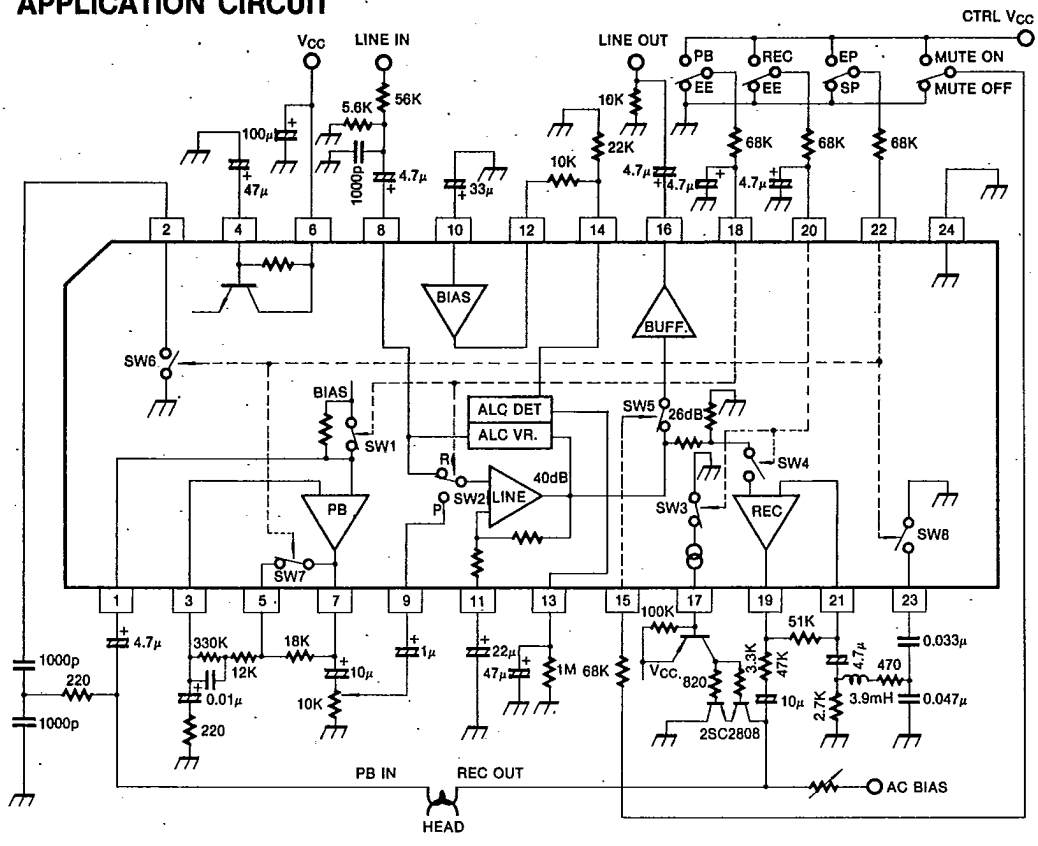

MODE CONTROL SWITCHING TIME

1. PB/EE Control: 18 Pin (REC/EE: "L")

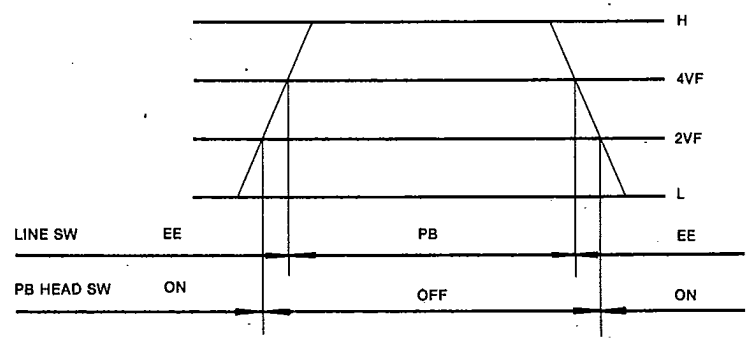

KA8401

LINEAR INTEGRATED CIRCUIT

2. REC/EE Control: 20 Pin (PB/EE: "L")

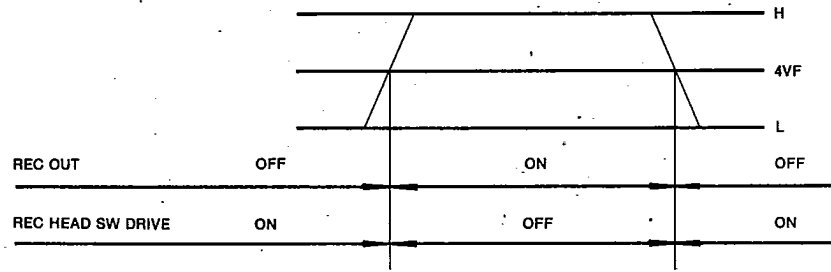

3. AFR/PB Control: 20 Pin (PB/EE: "H")

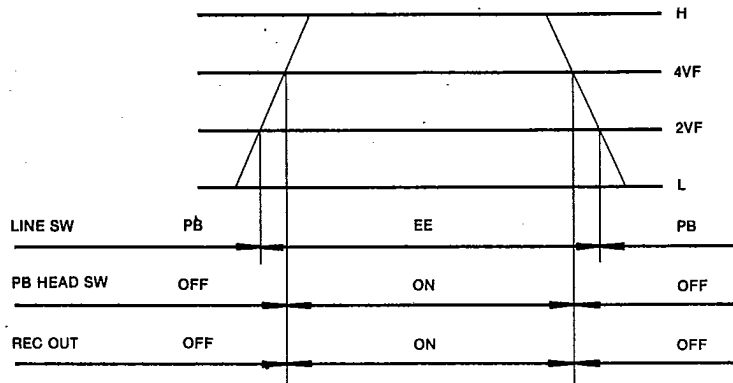

4. MUTE Control

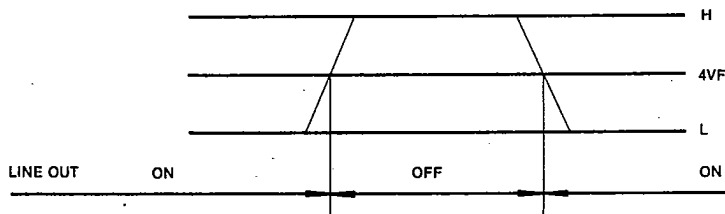

5. EP/SP Control

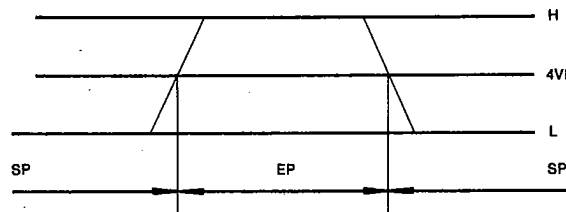

NOTE: VF \approx 6.8V