

Description

The SL5018/P is designed for use in FM dual conversion communication.

It contains a complete narrow band FM demodulation system operable to less than 2.0V supply voltage. This low power narrow band FM IF system provides the second converter, second IF, demodulator. Filter Amp and squelch circuitry for communications and scanning receivers.

Features

- Operating voltage range : 2.0V ~ 8.0V
- Low Current consumption $I_{CC} = 4.0\text{mA Typ.}$ ($V_{CC} = 4.0\text{V}$)
- Excellent input sensitivity (-3dB Limiting = $2.0 \mu\text{V}_{\text{rms Typ.}}$)
- Low number of external parts required
- Operating frequency up to 60MHz

Ordering Information

Type NO.	Marking	Package Code
SL5018	SL5018	SOP16
SL5018P	SL5018	DIP16

Outline Dmensions

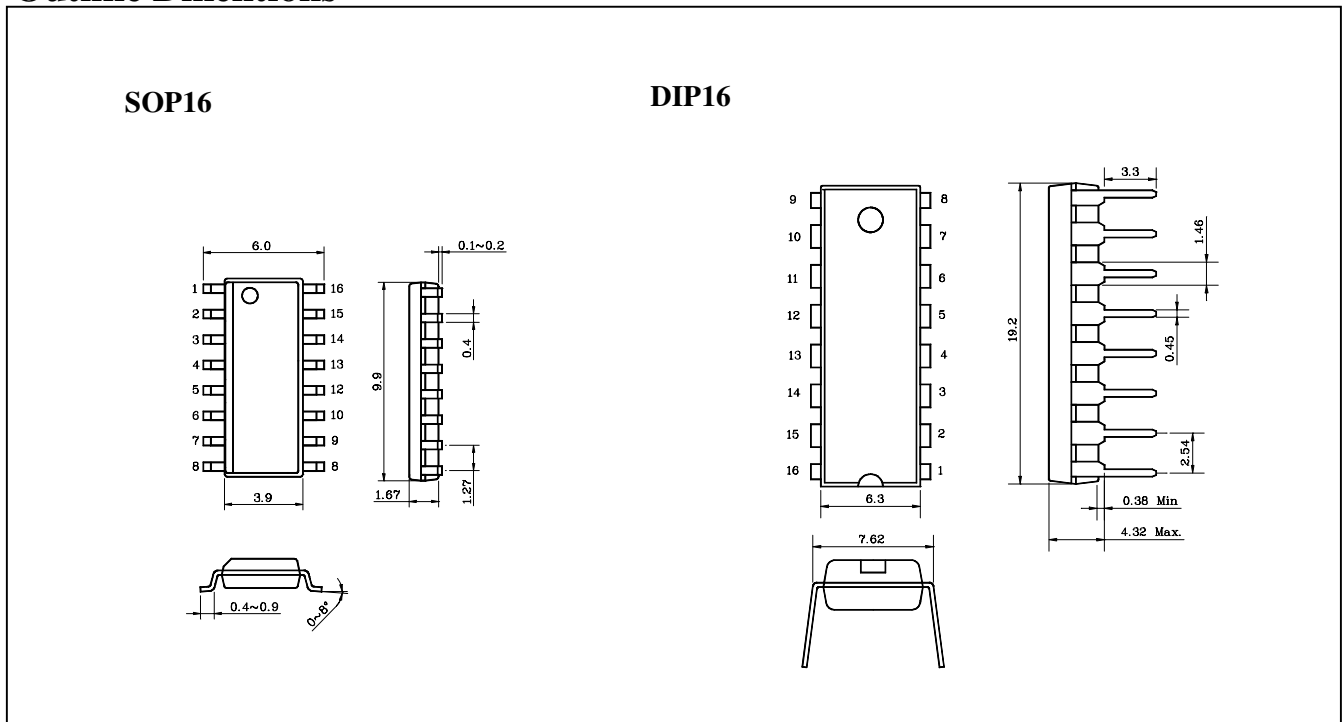

Absolute Maximum Ratings

(Ta=25 °C)

Characteristics	Symbol	Rating	Unit
Maximum Supply Voltage	$V_{CC(MAX)}$	10	V
Supply Voltage Range	V_{CC}	2.0 ~ 8.0	V
Detector input Voltage	$V_{IN(DET)}$	1.0	V_{p-p}
RF Input Voltage($V_{CC} \square 4.0V$)	$V_{IN(RF)}$	1.0	V_{rms}
Mute Function	V_{MUTE}	-0.5 ~ +5.0	V_{peak}
Operating Temperature	T_{opr}	-20 ~ +70	°C
Storage Temperature	T_{stg}	-65 ~ +150	°C

Electrical Characteristics

(Unless otherwise specified Ta=25 °C , Vcc=4V, fo=10.7MHz, fm=1kHz, Δf = ± 3kHz)

Characteristics	Symbol	Test Condition	Min.	Typ.	Max.	Unit
Squelch Current (No signal)	I_{CC1}	Squelch off($V_{12} = 2V$)	2.9	3.9	4.9	mA
	I_{CC2}	Squelch on($V_{12} = 0V$)	4.4	5.4	6.4	
Audio output Voltage	V_{OUT}	$V_{in} = 10mV_{rms}$	130	160	200	mV_{rms}
Input Limiting Voltage	$V_{IN(Lim)}$	-3dB Limiting	-	2.0	6.0	μV
Total Harmonic Distortion	THD	$V_{OUT} = 170mV_{rms}$	-	0.8	-	%
Recovered output Noise Voltage	V_{NO}	No Input Signal	60	80	250	mV_{rms}
Drop Voltage AF Gain Loss	$\square G_V$	$V_{CC} = 4V \square 2V$	-3	-0.6	-	dB
Detector Output Resistance	R_{OUT}	-	-	450	-	\square
Signal to Noise Ratio	S/N	-	36	67	-	dB
Filter Gain	G_V	$f = 10kHz, V_{in} = 5mV_{rms}$	40	50	-	dB
Filter Output DC voltage	$V_{O(DC)}$	-	1.0	1.3	1.6	V_{DC}
Mute Low Resistance	$R_{ON(Mute)}$	Mute Switch-on	-	10	-	\square
Mute High Resistance	$R_{off(Mute)}$	Mute Switch-off	1.0	10	-	$M\square$
Scan control Low	$V_{L(Scan)}$	Mute off($V_{12} = 2V$)	-	0	0.4	V_{DC}
Scan control High	$V_{H(Scan)}$	Mute on($V_{12} = 0V$)	3.0	3.5	-	V_{DC}
Trigger Hysteresis	V_{TH}	Squelch on/off	-	45	100	mV_{rms}
Mixer conversion Gain	$G_{V(Mix)}$	-	-	28	-	dB
Mixer Input Resistance	$R_{i(Mix)}$	-	-	3.3	-	$k\square$
Mixer Input Capacitance	$C_{i(Mix)}$	-	-	2.2	-	pF

PIN Configuration

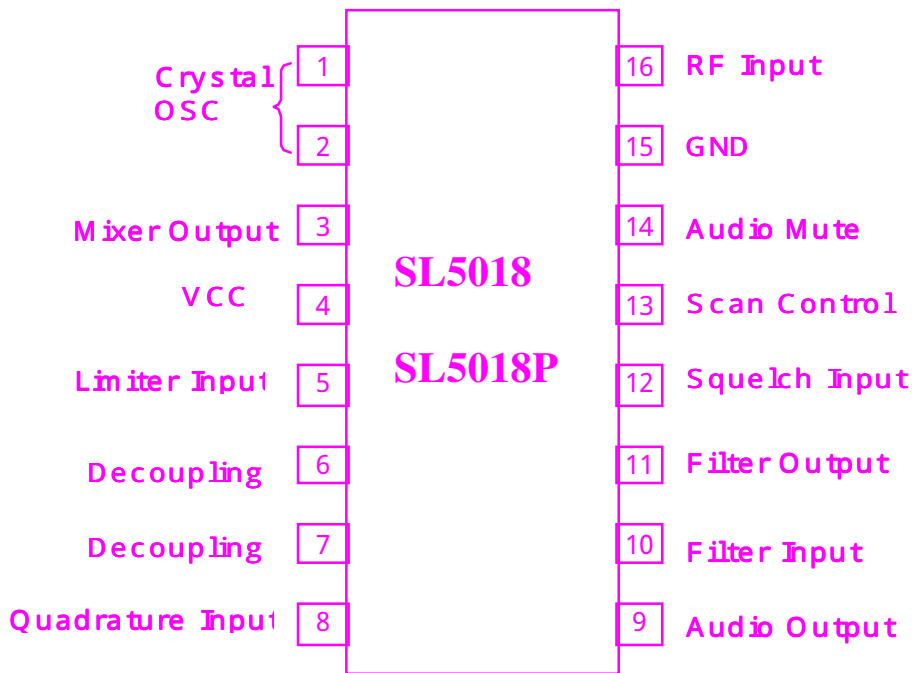

Block Diagram and Test Circuit

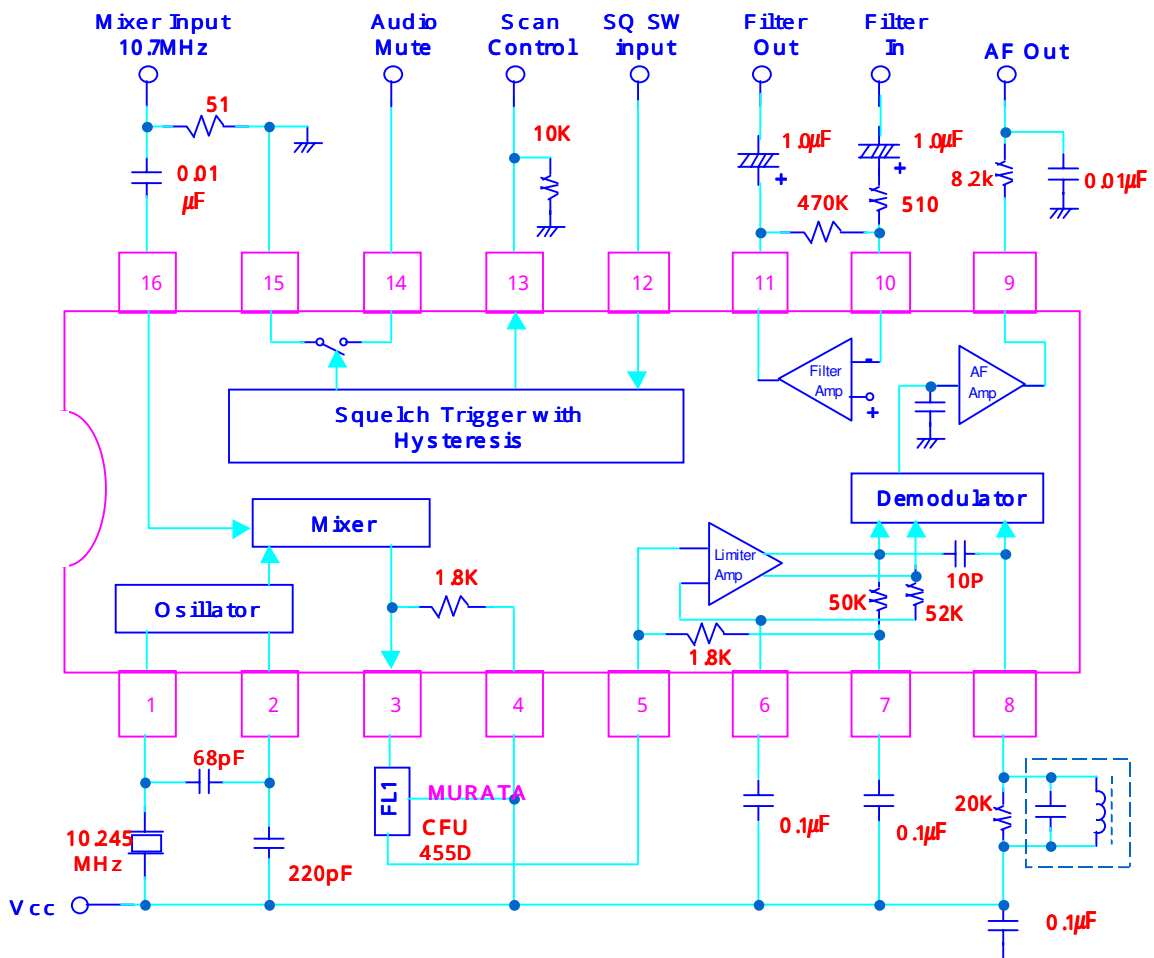

Application Circuit

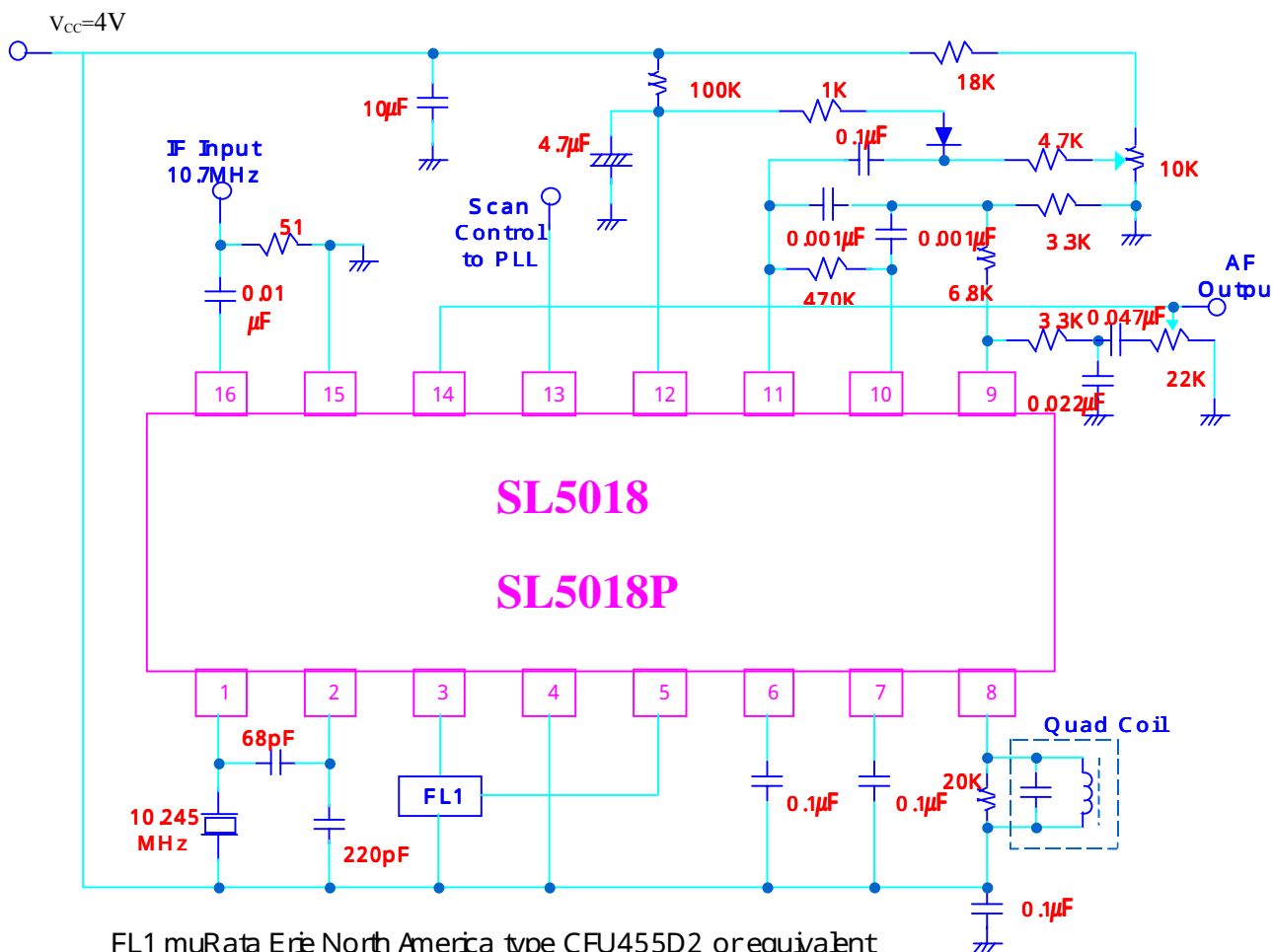

FL1 muRata Erie North America type CFU455D2 or equivalent
 Quadrature Coil Toko America type 7MC 8128Z or equivalent

Typical Performance Characteristics

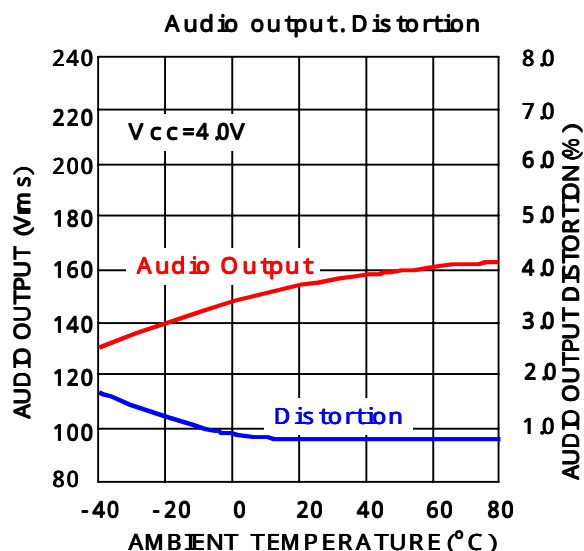
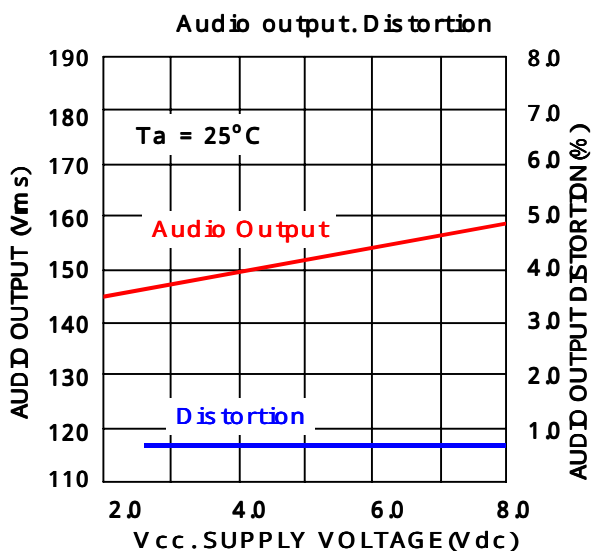

Typical Performance Characteristics (continued)

