

# DATA SHEET

## **TDA2616/TDA2616Q** 2 x 12 W hi-fi audio power amplifiers with mute

Product specification  
File under Integrated Circuits, IC01

July 1994

## 2 x 12 W hi-fi audio power amplifiers with mute

## TDA2616/TDA2616Q

### FEATURES

- Requires very few external components
- No switch-on/switch-off clicks
- Input mute during switch-on and switch-off
- Low offset voltage between output and ground
- Excellent gain balance of both amplifiers
- Hi-fi in accordance with IEC 268 and DIN 45500
- Short-circuit proof and thermal protected
- Mute possibility.

### GENERAL DESCRIPTION

The TDA2616 and TDA2616Q are dual power amplifiers. The TDA2616 is supplied in a 9-lead single-in-line (SIL9) plastic power package (SOT131), while the TDA2616Q is supplied in a 9-lead SIL-bent-to-DIL plastic power package (SOT157). They have been especially designed for mains fed applications, such as stereo radio and stereo TV.

### QUICK REFERENCE DATA

Stereo application

SYMBOL	PARAMETER	CONDITIONS	MIN.	TYP.	MAX.	UNIT
$\pm V_P$	supply voltage range		7.5	–	21	V
$P_O$	output power	$V_P = \pm 16$ V; THD = 0.5%	–	12	–	W
$G_V$	internal voltage gain		–	30	–	dB
$ G_V $	channel unbalance		–	0.2	–	dB
$\alpha$	channel separation		–	70	–	dB
SVRR	supply voltage ripple rejection		–	60	–	dB
$V_{no}$	noise output voltage		–	70	–	$\mu$ V

### ORDERING INFORMATION

EXTENDED TYPE NUMBER	PACKAGE			
	PINS	PIN POSITION	MATERIAL	CODE
TDA2616	9	SIL	plastic	SOT131 <sup>(1)</sup>
TDA2616Q	9	SIL-bent-to-DIL	plastic	SOT157 <sup>(2)</sup>

### Notes

1. SOT131-2; 1996 August 27.
2. SOT157-2; 1996 August 27.

2 x 12 W hi-fi audio power amplifiers with mute

TDA2616/TDA2616Q

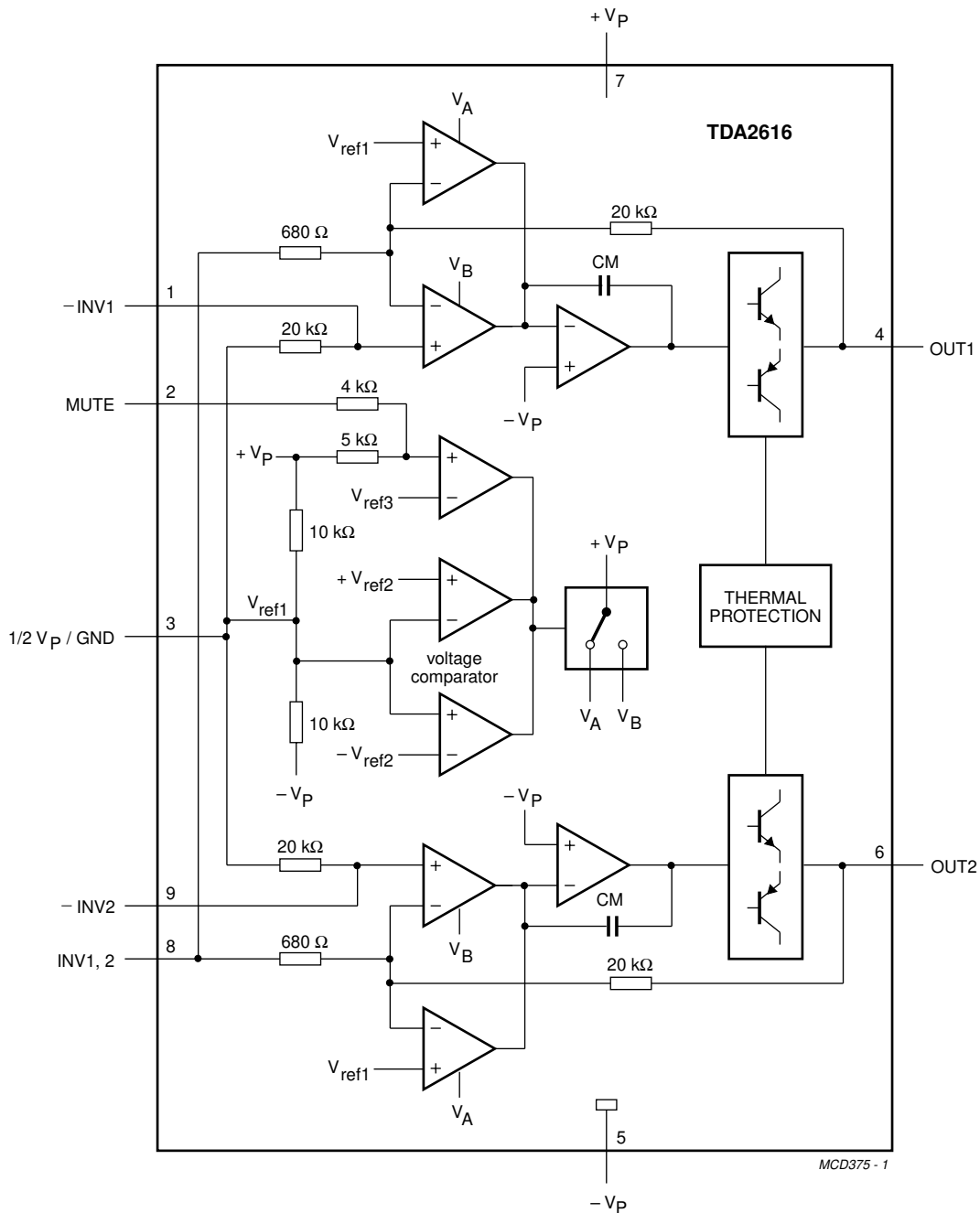

Fig.1 Block diagram.

## 2 x 12 W hi-fi audio power amplifiers with mute

## TDA2616/TDA2616Q

### PINNING

SYMBOL	PIN	DESCRIPTION
-INV1	1	non-inverting input 1
MUTE	2	mute input
1/2V <sub>P</sub> /GND	3	1/2 supply voltage or ground
OUT1	4	output 1
-V <sub>P</sub>	5	supply voltage (negative)
OUT2	6	output 2
+V <sub>P</sub>	7	supply voltage (positive)
INV1, 2	8	inverting inputs 1 and 2
-INV2	9	non-inverting input 2

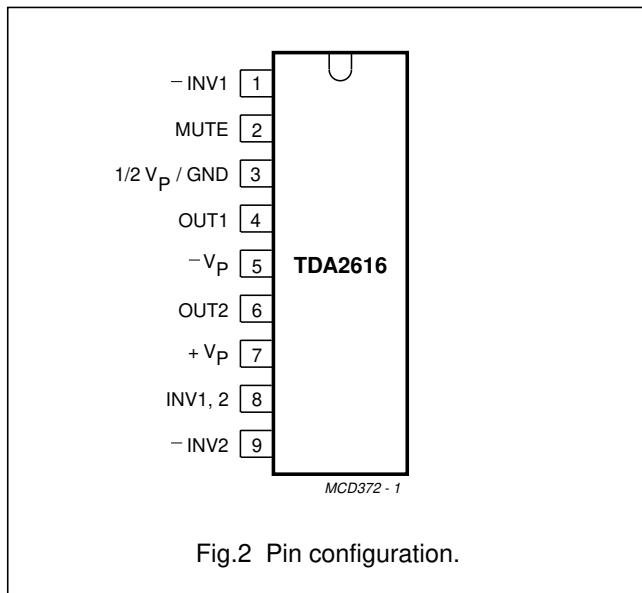

### FUNCTIONAL DESCRIPTION

The TDA2616 is a hi-fi stereo amplifier designed for mains fed applications, such as stereo radio and TV. The circuit is optimally designed for symmetrical power supplies, but is also well-suited to asymmetrical power supply systems.

An output power of  $2 \times 12$  W (THD = 0.5%) can be delivered into an  $8 \Omega$  load with a symmetrical power supply of  $\pm 16$  V. The gain is internally fixed at 30 dB, thus offering a low gain spread and a very good gain balance between the two amplifiers (0.2 dB).

A special feature is the input mute circuit. This circuit disconnects the non-inverting inputs when the supply voltage drops below  $\pm 6$  V, while the amplifier still retains its DC operating adjustment. The circuit features suppression of unwanted signals at the inputs, during switch-on and switch-off.

The mute circuit can also be activated via pin 2. When a current of  $300 \mu\text{A}$  is present at pin 2, the circuit is in the mute condition.

The device is provided with two thermal protection circuits. One circuit measures the average temperature of the crystal and the other measures the momentary temperature of the power transistors. These control circuits attack at temperatures in excess of  $+150^\circ\text{C}$ , so a crystal operating temperature of max.  $+150^\circ\text{C}$  can be used without extra distortion.

With the derating value of  $2.5 \text{ K/W}$ , the heatsink can be calculated as follows:

at  $R_L = 8 \Omega$  and  $V_P = \pm 16$  V, the measured maximum dissipation is  $14.6 \text{ W}$ .

With a maximum ambient temperature of  $+65^\circ\text{C}$ , the thermal resistance of the heatsink is:

$$R_{\text{th}} = \frac{150 - 65}{14.6} - 2.5 = 3.3 \text{ K/W.}$$

The internal metal block has the same potential as pin 5.

# 2 x 12 W hi-fi audio power amplifiers with mute

## TDA2616/TDA2616Q

### LIMITING VALUES

In accordance with the Absolute maximum System (IEC 134).

SYMBOL	PARAMETER	CONDITIONS	MIN.	MAX.	UNIT
$\pm V_P$	supply voltage		–	21	V
$I_{OSM}$	non-repetitive peak output current		–	4	A
$P_{tot}$	total power dissipation	see Fig.3	–	25	W
$T_{stg}$	storage temperature range		–55	+150	°C
$T_{XTAL}$	crystal temperature		–	+150	°C
$T_{amb}$	ambient operating temperature range		–25	150	°C
$t_{sc}$	short circuit time	short-circuit to ground; note 1	–	1	h

### Note to the limiting values

- For asymmetrical power supplies (with the load short-circuited), the maximum unloaded supply voltage is limited to  $V_P = 28\text{ V}$  and with an internal supply resistance of  $R_S \geq 4\ \Omega$ , the maximum unloaded supply voltage is limited to 32 V (with the load short-circuited). For symmetrical power supplies the circuit is short-circuit-proof up to  $V_P = \pm 21\text{ V}$ .

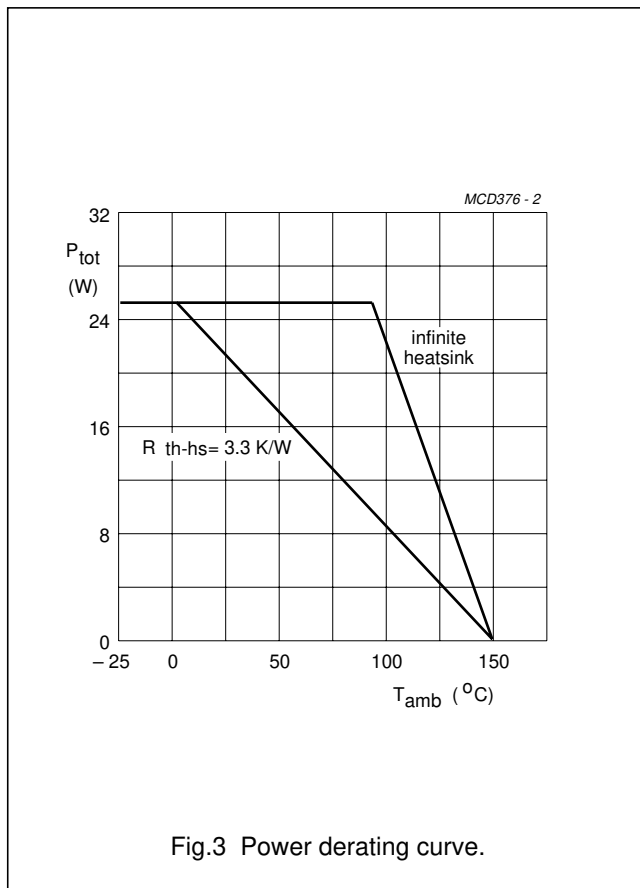

Fig.3 Power derating curve.

### THERMAL RESISTANCE

SYMBOL	PARAMETER	THERMAL RESISTANCE
$R_{th\ j-a}$	from junction to ambient in free air	2.5 K/W

## 2 x 12 W hi-fi audio power amplifiers with mute

TDA2616/TDA2616Q

### CHARACTERISTICS

SYMBOL	PARAMETER	CONDITIONS	MIN.	TYP.	MAX.	UNIT
<b>Supply</b>						
$\pm V_P$	supply voltage range		–	16	21	V
$I_{ORM}$	repetitive peak output current		–	2.2	–	A
<b>Operating position; note 1</b>						
$\pm V_P$	supply voltage range		7.5	16	21	V
$I_P$	total quiescent current	$R_L = \infty$	18	40	70	mA
$P_O$	output power	THD = 0.5% THD = 10%	10 12	12 15	– –	W W
THD	total harmonic distortion	$P_O = 6\text{ W}$	–	0.15	0.2	%
B	power bandwidth	THD = 0.5%; note 2	–	20 to 20 000	–	Hz
$G_v$	voltage gain		29	30	31	dB
$ G_v $	gain unbalance		–	0.2	1	dB
$V_{no}$	noise output voltage	note 3	–	70	140	$\mu\text{V}$
$ Z_i $	input impedance		14	20	26	$\text{k}\Omega$
SVRR	supply voltage ripple rejection	note 4	40	60	–	dB
$\alpha$	channel separation	$R_S = 0$	46	70	–	dB
$I_{bias}$	input bias current		–	0.3	–	$\mu\text{A}$
$ \Delta V_{GND} $	DC output offset voltage		–	30	200	mV
$ \Delta V_{4-6} $	DC output offset voltage	between two channels	–	4	150	mV
<b>MUTE POSITION (AT <math>I_{MUTE} \geq 300\ \mu\text{A}</math>)</b>						
$V_O$	output voltage	$V_I = 600\text{ mV}$	–	0.3	1.0	mV
$Z_{2-7}$	mute input impedance	note 7	6.7	9	11.3	$\text{k}\Omega$
$I_P$	total quiescent current	$R_L = \infty$	18	40	70	mA
$V_{no}$	noise output voltage	note 3	–	70	140	$\mu\text{V}$
SVRR	supply voltage ripple rejection	note 4	40	55	–	dB
$ \Delta V_{GND} $	DC output offset voltage		–	40	200	mV
$ \Delta V_{off} $	offset voltage with respect to operating position		–	4	150	mV
$I_2$	current if pin 2 is connected to pin 5		–	–	8.2	mA
<b>Mute position; note 5</b>						
$\pm V_P$	supply voltage range		2	–	5.8	V
$I_P$	total quiescent current	$R_L = \infty$	9	30	40	mA
$V_O$	output voltage	$V_I = 600\text{ mV}$	–	0.3	1.0	mV
$V_{no}$	noise output voltage	note 3	–	70	140	$\mu\text{V}$
SVRR	supply voltage ripple rejection	note 4	40	55	–	dB

## 2 x 12 W hi-fi audio power amplifiers with mute

TDA2616/TDA2616Q

SYMBOL	PARAMETER	CONDITIONS	MIN.	TYP.	MAX.	UNIT
$ \Delta V_{\text{GND}} $	DC output offset voltage		–	40	200	mV
<b>Operating position; note 6</b>						
$I_{\text{P}}$	total quiescent current		18	40	70	mA
$P_{\text{O}}$	output power	THD = 0.5%	5	6	–	W
		THD = 10%	6.5	8	–	W
		THD = 0.5%; $R_{\text{L}} = 4 \Omega$	–	10	–	W
		THD = 10%; $R_{\text{L}} = 4 \Omega$	–	14	–	W
THD	total harmonic distortion	$P_{\text{O}} = 4 \text{ W}$	–	0.13	0.2	%
B	power bandwidth	THD = 0.5%; note 2	–	40 to 20 000	–	Hz
$G_{\text{V}}$	voltage gain		29	30	31	dB
$ G_{\text{V}} $	gain unbalance		–	0.2	1	dB
$V_{\text{no}}$	noise output voltage	note 3	–	70	140	$\mu\text{V}$
$ Z_{\text{i}} $	input impedance		14	20	26	$\text{k}\Omega$
SVRR	supply voltage ripple rejection		35	44	–	dB
$\alpha$	channel separation		–	45	–	dB
<b>MUTE POSITION (<math>I_{\text{MUTE}} \geq 300 \mu\text{A}</math>)</b>						
$V_{\text{O}}$	output voltage	$V_{\text{I}} = 600 \text{ mV}$	–	0.3	1.0	mV
$Z_{2-7}$	mute input impedance	note 7	6.7	9	11.3	$\text{k}\Omega$
$I_{\text{P}}$	total quiescent current		18	40	70	mA
$V_{\text{no}}$	noise output voltage	note 3	–	70	140	$\mu\text{V}$
SVRR	supply voltage ripple rejection	note 4	35	44	–	dB
$ \Delta V_{\text{off}} $	offset voltage with respect to operating position		–	4	150	mV
$I_2$	current if pin 2 is connected to pin 5		–	–	8.2	mA

### Notes to the characteristics

- $V_{\text{P}} = \pm 16 \text{ V}$ ;  $R_{\text{L}} = 8 \Omega$ ;  $T_{\text{amb}} = 25 \text{ }^\circ\text{C}$ ;  $f = 1 \text{ kHz}$ ; symmetrical power supply  $I_{\text{MUTE}} < 30 \mu\text{A}$ . See Fig.4
- The power bandwidth is measured at an output power of  $P_{\text{O max}} - 3 \text{ dB}$
- The noise output voltage (RMS value) is measured at  $R_{\text{S}} = 2 \text{ k}\Omega$ , unweighted (20 Hz to 20 kHz)
- The ripple rejection is measured at  $R_{\text{S}} = 0$  and  $f = 100 \text{ Hz}$  to 20 kHz. The ripple voltage (200 mV) is applied in phase to the positive and the negative supply rails. With asymmetrical power supplies, the ripple rejection is measured at  $f = 1 \text{ kHz}$
- $\pm V_{\text{P}} = 4 \text{ V}$ ;  $R_{\text{L}} = 8 \Omega$ ;  $T_{\text{amb}} = 25 \text{ }^\circ\text{C}$ ;  $f = 1 \text{ kHz}$ ; symmetrical power supply. See Fig.4
- $V_{\text{P}} = 24 \text{ V}$ ;  $R_{\text{L}} = 8 \Omega$ ;  $T_{\text{amb}} = 25 \text{ }^\circ\text{C}$ ;  $f = 1 \text{ kHz}$ ; asymmetrical power supply  $I_{\text{MUTE}} < 30 \mu\text{A}$ . See Fig.5
- The internal network at pin 2 is a resistor divider of typical 4 k $\Omega$  and 5 k $\Omega$  to the positive supply rail. At the connection of the 4 k $\Omega$  and 5 k $\Omega$  resistor a zener diode of typical 6.6 V is also connected to the positive supply rail. The spread of the zener voltage is 6.1 to 7.1 V.

2 x 12 W hi-fi audio power amplifiers with mute

TDA2616/TDA2616Q

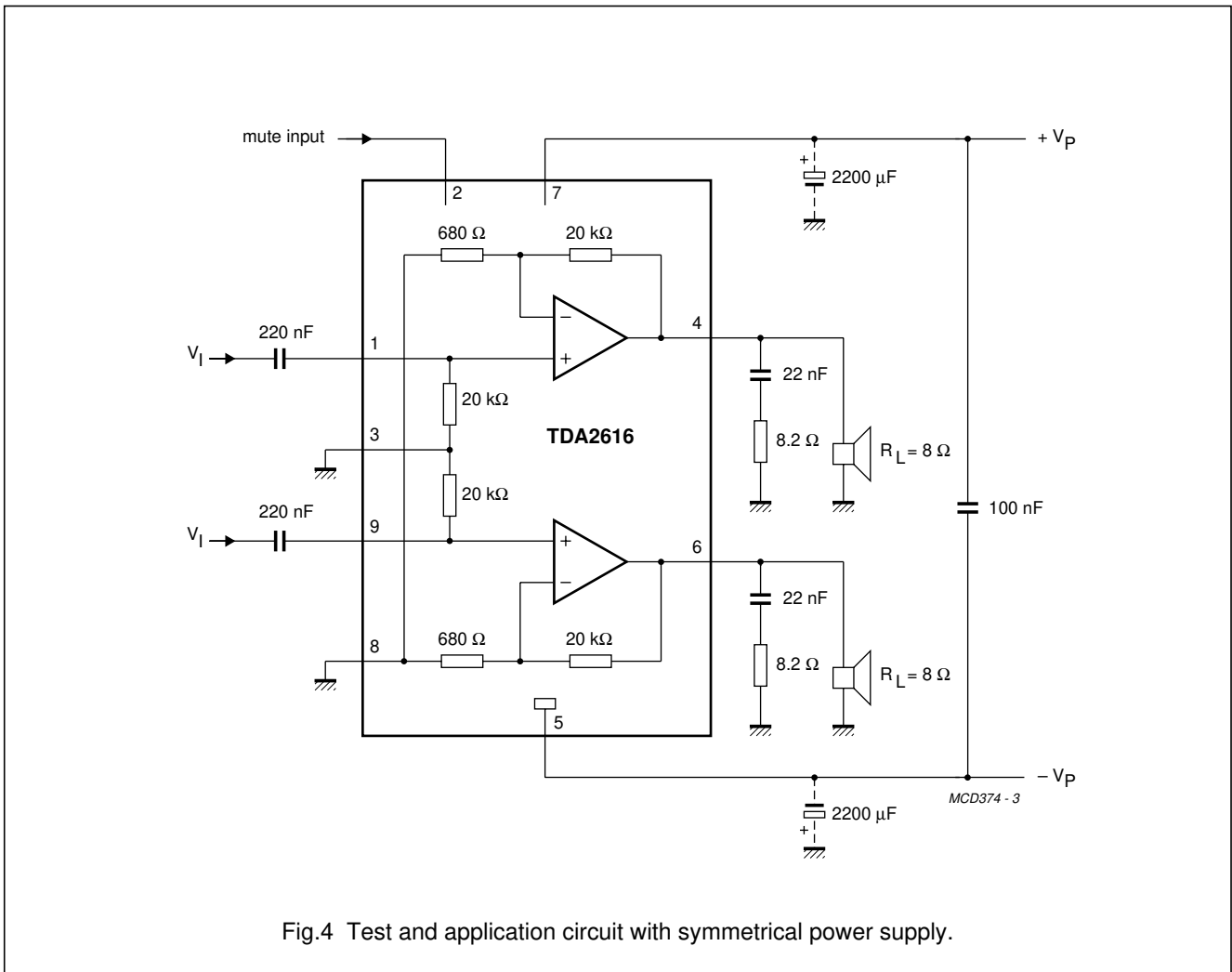

Fig.4 Test and application circuit with symmetrical power supply.



2 x 12 W hi-fi audio power amplifiers with mute

TDA2616/TDA2616Q

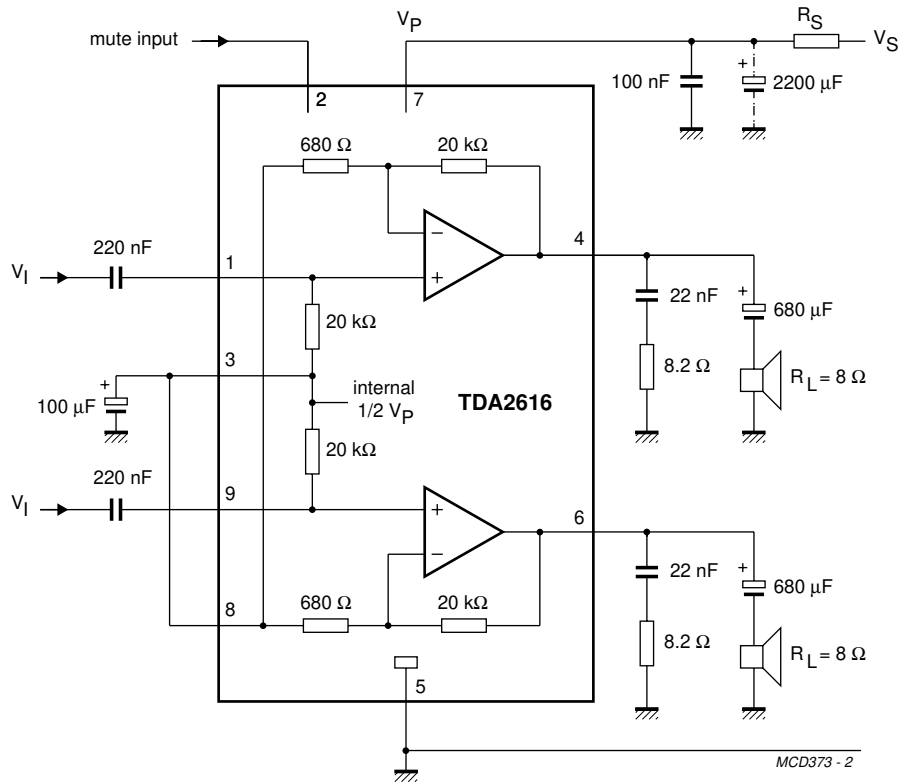

Fig.5 Test and application circuit with asymmetrical power supply.

# 2 x 12 W hi-fi audio power amplifiers with mute

## TDA2616/TDA2616Q

### PACKAGE OUTLINES

SIL9P: plastic single in-line power package; 9 leads

SOT131-2

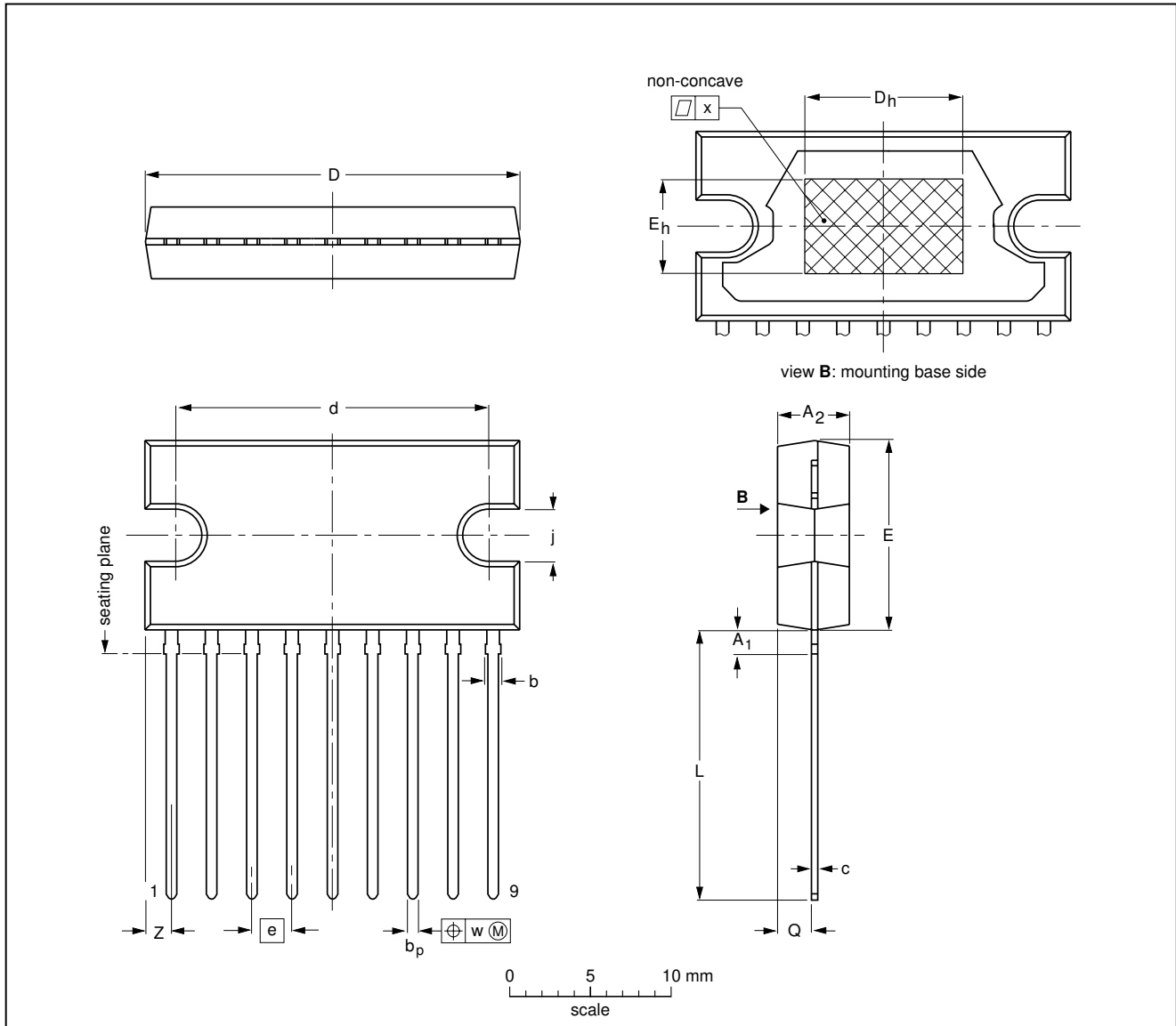

**DIMENSIONS (mm are the original dimensions)**

UNIT	A <sub>1</sub> max.	A <sub>2</sub>	b max.	b <sub>p</sub>	c	D <sup>(1)</sup>	d	D <sub>h</sub>	E <sup>(1)</sup>	e	E <sub>h</sub>	j	L	Q	w	x	Z <sup>(1)</sup>
mm	2.0	4.6 4.2	1.1	0.75 0.60	0.48 0.38	24.0 23.6	20.0 19.6	10	12.2 11.8	2.54	6	3.4 3.1	17.2 16.5	2.1 1.8	0.25	0.03	2.00 1.45

**Note**

1. Plastic or metal protrusions of 0.25 mm maximum per side are not included.

OUTLINE VERSION	REFERENCES				EUROPEAN PROJECTION	ISSUE DATE
	IEC	JEDEC	EIAJ			
SOT131-2						92-11-17 95-03-11

2 x 12 W hi-fi audio power amplifiers with mute

TDA2616/TDA2616Q

DBS9P: plastic DIL-bent-SIL power package; 9 leads (lead length 12 mm)

SOT157-2

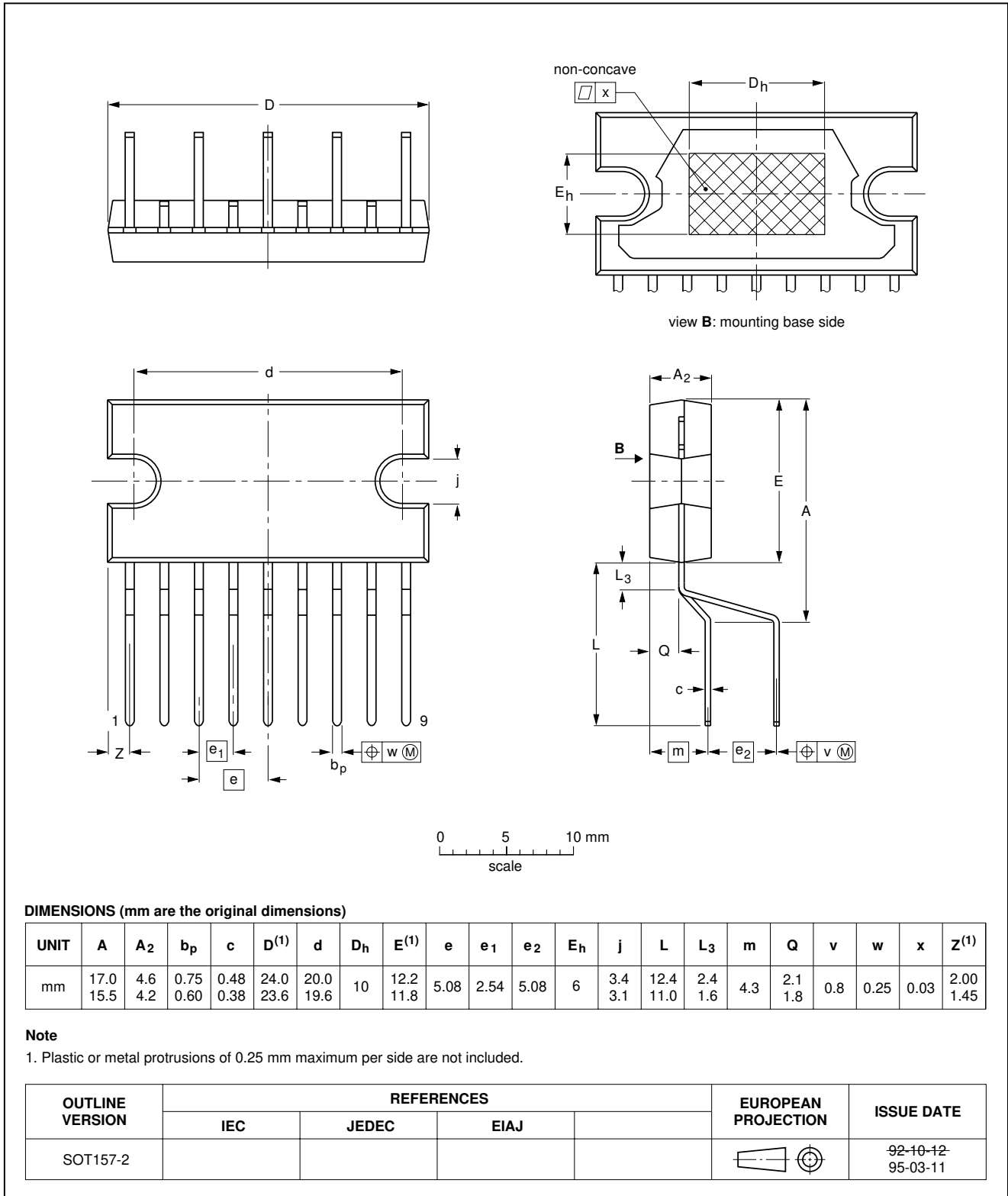

## 2 x 12 W hi-fi audio power amplifiers with mute

## TDA2616/TDA2616Q

### SOLDERING

#### Introduction

There is no soldering method that is ideal for all IC packages. Wave soldering is often preferred when through-hole and surface mounted components are mixed on one printed-circuit board. However, wave soldering is not always suitable for surface mounted ICs, or for printed-circuits with high population densities. In these situations reflow soldering is often used.

This text gives a very brief insight to a complex technology. A more in-depth account of soldering ICs can be found in our "IC Package Databook" (order code 9398 652 90011).

#### Soldering by dipping or by wave

The maximum permissible temperature of the solder is 260 °C; solder at this temperature must not be in contact with the joint for more than 5 seconds. The total contact time of successive solder waves must not exceed 5 seconds.

The device may be mounted up to the seating plane, but the temperature of the plastic body must not exceed the specified maximum storage temperature ( $T_{stg\ max}$ ). If the printed-circuit board has been pre-heated, forced cooling may be necessary immediately after soldering to keep the temperature within the permissible limit.

#### Repairing soldered joints

Apply a low voltage soldering iron (less than 24 V) to the lead(s) of the package, below the seating plane or not more than 2 mm above it. If the temperature of the soldering iron bit is less than 300 °C it may remain in contact for up to 10 seconds. If the bit temperature is between 300 and 400 °C, contact may be up to 5 seconds.

### DEFINITIONS

Data sheet status	
Objective specification	This data sheet contains target or goal specifications for product development.
Preliminary specification	This data sheet contains preliminary data; supplementary data may be published later.
Product specification	This data sheet contains final product specifications.
Limiting values	
Limiting values given are in accordance with the Absolute Maximum Rating System (IEC 134). Stress above one or more of the limiting values may cause permanent damage to the device. These are stress ratings only and operation of the device at these or at any other conditions above those given in the Characteristics sections of the specification is not implied. Exposure to limiting values for extended periods may affect device reliability.	
Application information	
Where application information is given, it is advisory and does not form part of the specification.	

### LIFE SUPPORT APPLICATIONS

These products are not designed for use in life support appliances, devices, or systems where malfunction of these products can reasonably be expected to result in personal injury. Philips customers using or selling these products for use in such applications do so at their own risk and agree to fully indemnify Philips for any damages resulting from such improper use or sale.

This datasheet has been download from:

[www.datasheetcatalog.com](http://www.datasheetcatalog.com)

Datasheets for electronics components.