

5.8W AUDIO POWER AMPLIFIER.
CAR STEREO, CAR RADIO OUTPUT.

FEATURES

- Output Power
: $P_{OUT}=5.8W$ (Typ.) at $V_{CC}=13.2V$, $R_L=4\Omega$, THD=10%
: $P_{OUT}=9.2W$ (Typ.) at $V_{CC}=13.2V$, $R_L=2\Omega$, THD=10%
- Maximum Output Power :
: $P_{OM}=9.5W$ (Typ.) at $V_{CC}=13.2V$, $R_L=4\Omega$
- Low Distortion : THD=0.15% at $P_{OUT}=1W$, $G_V=55dB$
THD=0.07% at $P_{OUT}=1W$, $G_V=44dB$
- Wide Operating Supply Voltage Range : $V_{CC}=9\sim 18V$
- Minimum Working Voltage : 9V
- Excessive Supply Voltage Protection Circuit.
- Current Limiting for Short Circuit Protection.
- Thermal Shut-down Circuit.

MAXIMUM RATINGS ($T_a=25^\circ C$)

CHARACTERISTIC	SYMBOL	RATING	UNIT
Operating Supply Voltage	V_{CC}	18	V
Quiescent Supply Voltage	V_{CCQ}	25	V
Output Current (Peak)	$I_{O(peak)}$	4.5	A
Power Dissipation	P_D	7.5	W
Operating Temperature	T_{opr}	-20~75	$^\circ C$
Storage Temperature	T_{stg}	-55~150	$^\circ C$

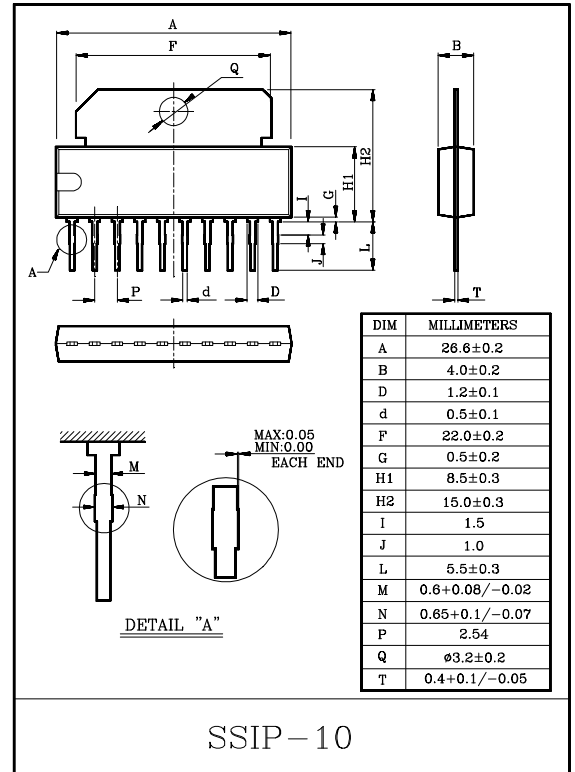

ELECTRICAL CHARACTERISTICS

(Unless otherwise specified. $V_{CC}=12.5V$, $R_L=4\Omega$, $R_g=600\Omega$, $R_f=82\Omega$, $f=1kHz$, $T_a=25^\circ C$)

CHARACTERISTIC	SYMBOL	TEST CIRCUIT	TEST CONDITION	MIN.	TYP.	MAX.	UNIT
Quiescent Current	I_{CCQ}	-	-	-	-	60	mA
			$V_{CC}=18V$	-	-	80	
Output Power	P_{OUT}	-	THD=10%	4.5	5	-	W
			$V_{CC}=13.2V$, THD=10%	-	5.8	-	
			$V_{CC}=13.2V$, $R_L=2\Omega$, THD=10%	-	9.2	-	
Maximum Output Voltage	P_{OM}	-	$V_{CC}=13.2V$	-	9.5	-	W
Total Harmonic Distortion	THD	-	$P_{OUT}=1W$	-	0.15	1.0	%
			$P_{OUT}=100mW$	-	0.2	1.0	
			$P_{OUT}=1W$, $R_L=2\Omega$	-	0.25	1.0	
Voltage Gain (Note)	G_V	-	$V_{IN}=2.45mV_{rms}$	52	-	58	dB
Input Resistance	R_{IN}	-	$V_{OUT}=2V_{rms}$	30	40	-	k Ω
Output Noise Voltage	V_{NO}	-	$R_g=10k\Omega$, BW=50~20kHz	-	-	3.5	mV

Note : In regard to the value of voltage gain (closed loop voltage), it is possible to be classified.

KIA7217AP

EQUIVALENT CIRCUIT

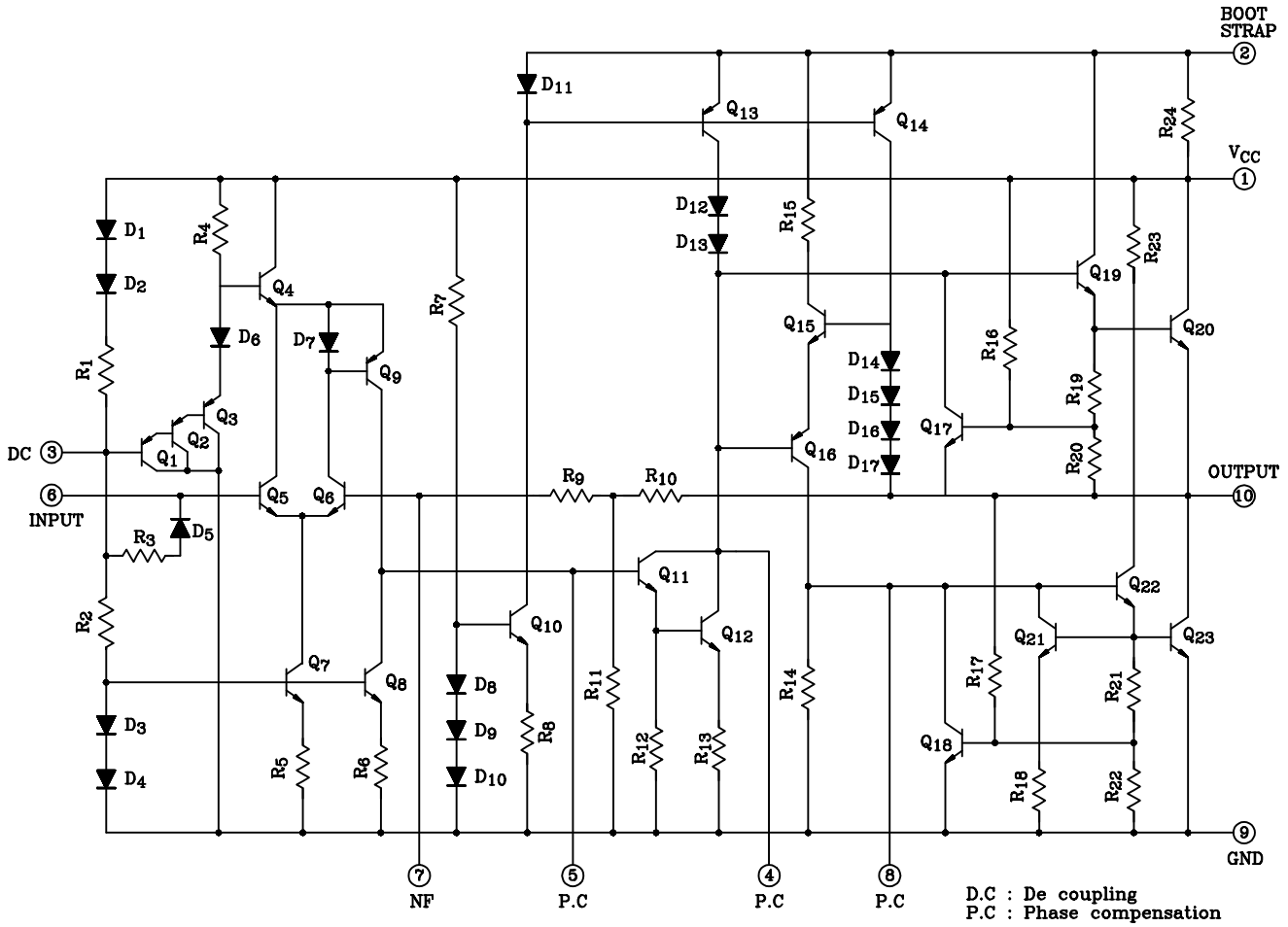

TEST AND APPLICATION CIRCUIT

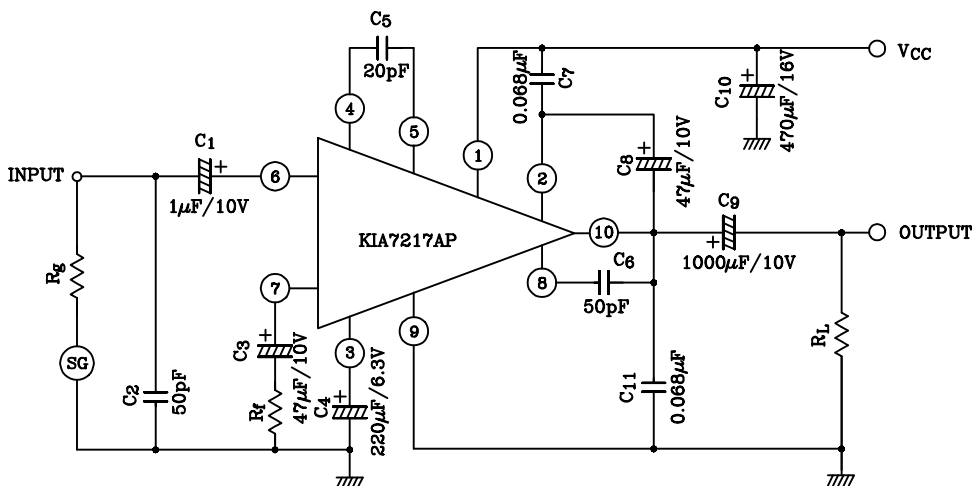

KIA7217AP

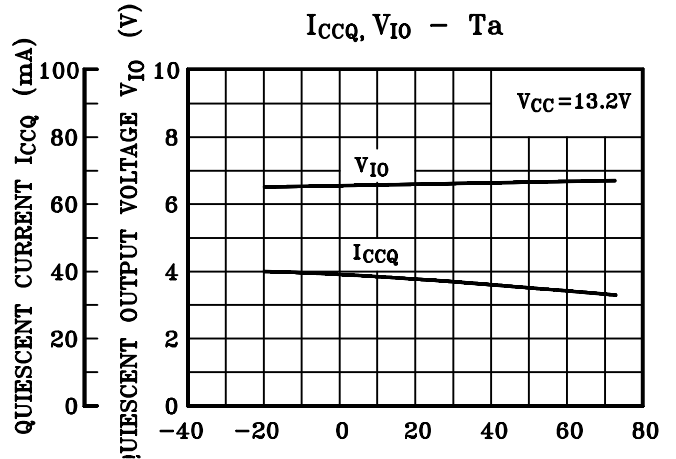
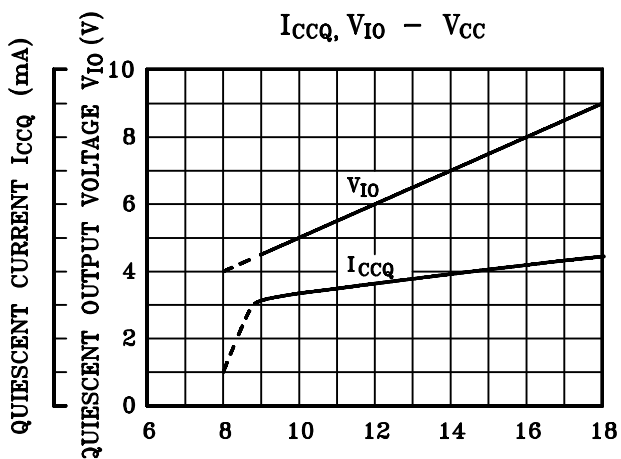
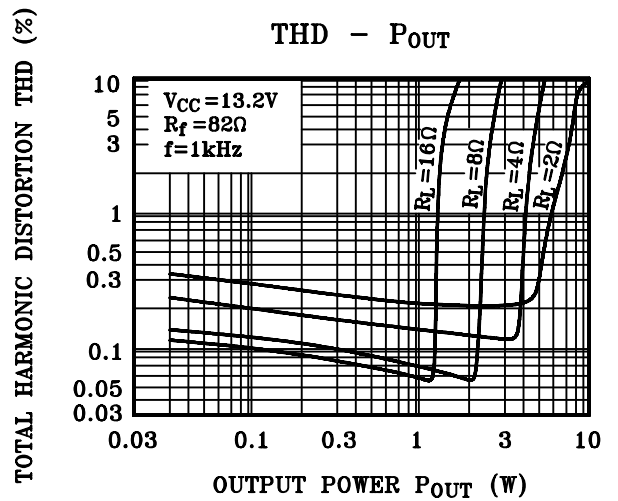
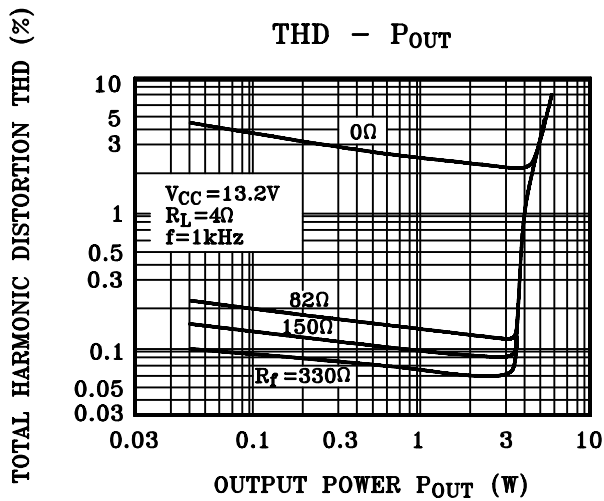
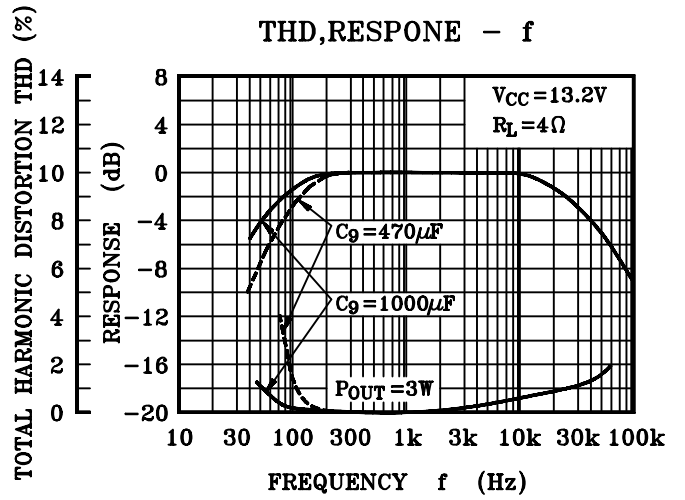
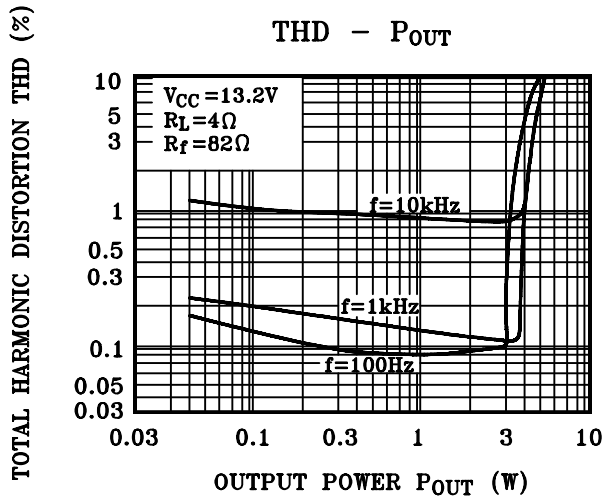

KIA7217AP

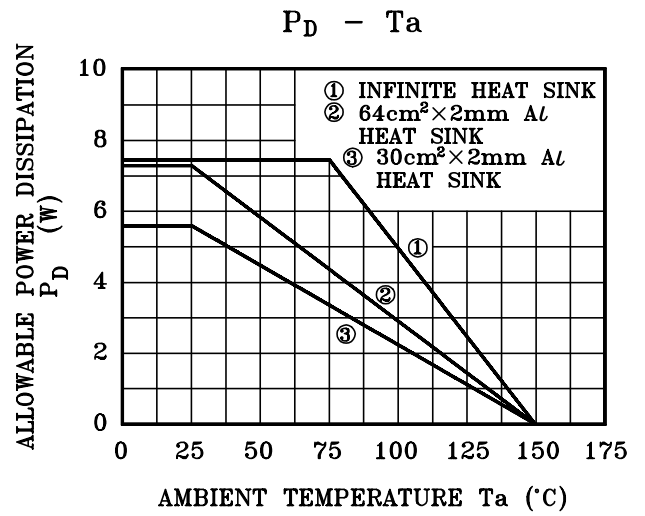
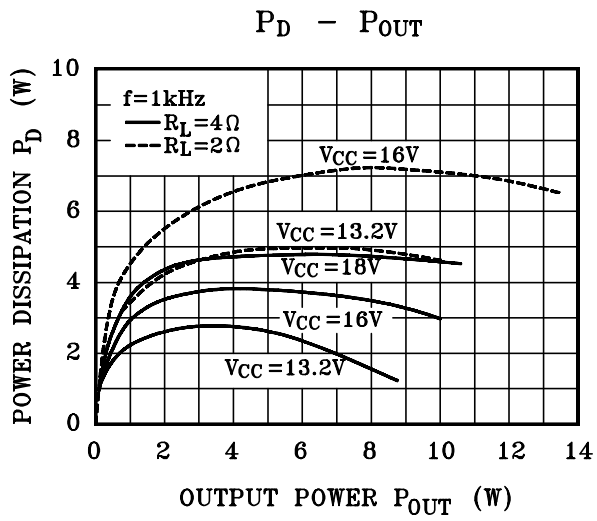

This datasheet has been download from:

www.datasheetcatalog.com

Datasheets for electronics components.