FUJI Power Supply Control IC

PWM Control IC
with Light Load Power Saving Function

FA3641P/N
FA3647P/N

Application Note

*July '00
Fuji Electric Co., Ltd.
Matsumoto Factory*

WARNING

1. This Data Book contains the product specifications, characteristics, data, materials, and structures as of July 2000. The contents are subject to change without notice for specification changes or other reasons. When using a product listed in this Data Book, be sure to obtain the latest specifications.
2. All applications described in this Data Book exemplify the use of Fuji's products for your reference only. No right or license, either express or implied, under any patent, copyright, trade secret or other intellectual property right owned by Fuji Electric Co., Ltd. is (or shall be deemed) granted. Fuji makes no representation or warranty, whether express or implied, relating to the infringement or alleged infringement of other's intellectual property rights which may arise from the use of the applications described herein.
3. Although Fuji Electric is enhancing product quality and reliability, a small percentage of semiconductor products may become faulty. When using Fuji Electric semiconductor products in your equipment, you are requested to take adequate safety measures to prevent the equipment from causing a physical injury, fire, or other problem if any of the products become faulty. It is recommended to make your design fail-safe, flame retardant, and free of malfunction.
4. The products introduced in this Data Book are intended for use in the following electronic and electrical equipment which has normal reliability requirements.
 - Computers • OA equipment • Communications equipment (terminal devices)
 - Measurement equipment • Machine tools • Audiovisual equipment • Electrical home appliances
 - Personal equipment • Industrial robots etc.
5. If you need to use a product in this Data Book for equipment requiring higher reliability than normal, such as for the equipment listed below, it is imperative to contact Fuji Electric to obtain prior approval. When using these products for such equipment, take adequate measures such as a backup system to prevent the equipment from malfunctioning even if a Fuji's product incorporated in the equipment becomes faulty.
 - Transportation equipment (mounted on cars and ships) • Trunk communications equipment
 - Traffic-signal control equipment • Gas leakage detectors with an auto-shut-off feature
 - Emergency equipment for responding to disasters and anti-burglary devices • Safety devices
6. Do not use products in this Data Book for the equipment requiring strict reliability such as (without limitation)
 - Space equipment • Aeronautic equipment • Atomic control equipment
 - Submarine repeater equipment • Medical equipment
7. Copyright © 1995 by Fuji Electric Co., Ltd. All rights reserved. No part of this Data Book may be reproduced in any form or by any means without the express permission of Fuji Electric.
8. If you have any question about any portion in this Data Book, ask Fuji Electric or its sales agents before using the product. Neither Fuji nor its agents shall be liable for any injury caused by any use of the products not in accordance with instructions set forth herein.

CONTENTS

	page
1. Description	4
2. Features	4
3. Outline	4
4. Block diagram	5
5. Pin assignment	5
6. Ratings and characteristics	6
7. Characteristics curves	9
8. Description of each circuit	12
9. Design advice	16
10. Application circuit	23

Note

- Parts tolerance and characteristics are not defined in all application described in this Data book. When design an actual circuit for a product, you must determine parts tolerances and characteristics for safe and economical operation.

1. Description

The FA3641 and FA3647 are the PWM type switching power supply control ICs that can directly drive power MOSFET. These ICs use a CMOS device with high dielectric strength (30V) to implement low power consumption. They feature a number of functions that are equivalent to those of the FA531x series consisting of bipolar devices. In addition, they have a function that reduces the oscillation frequency to suppress loss in light load mode and support an overvoltage protection function detecting Vcc voltage. These ICs are most suitable for high-performance, energy-saving power supplies that require low input power in standby or no-load mode.

2. Features

- Uses a newly developed CMOS process with high dielectric strength (30V) for implementing low power consumption
- Standby current of 2 μ A or less (at Vcc = 14V), and operating current of 1.9mA (typ)
- Automatically reduces the oscillation frequency to suppress loss in light load mode
- Overvoltage protection function that detecting the Vcc voltage
- A drive circuit for connecting a power MOSFET directly
- Output peak current: Source current -500mA, sink current +1A
- Pulse-by-pulse overcurrent restriction function
- Overload protection function (latch or non-latch mode selectable)
- Output ON-OFF function by external signal
- Latch-mode overvoltage shutdown function
- Undervoltage lockout function (16.5V ON/9V OFF)
- Reference voltage output (5V)
- 8-pin package (DIP/SOP)

3. Outline

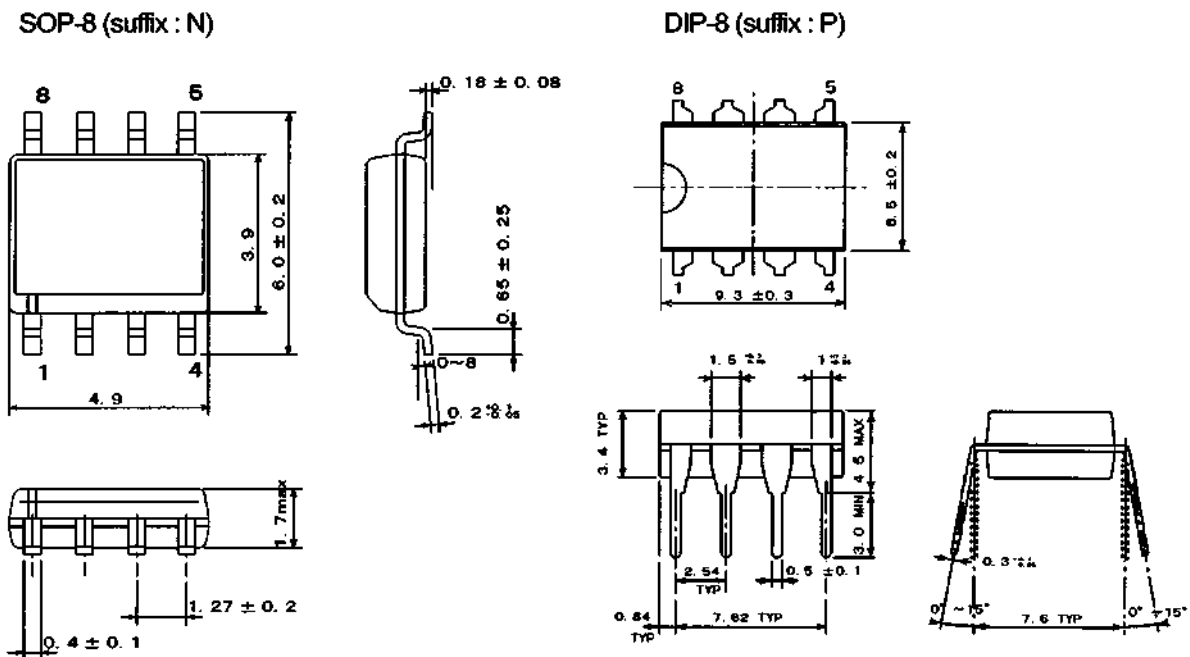

4. Block diagram

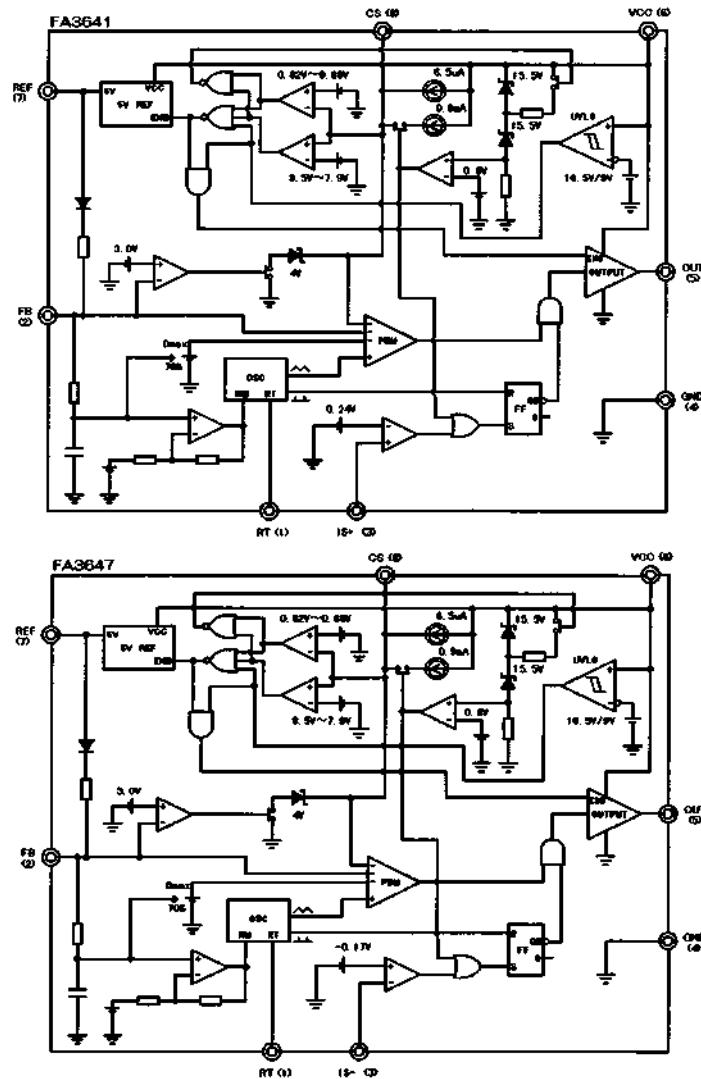

5. Pin assignment

pin	symbol	function	description
1	RT	Oscillator timing resistor	Setting oscillation frequency
2	FB	Feedback	Input of PWM comparator
3	IS	Overcurrent detection	Input of the overcurrent limiting function
4	GND	Ground	Ground
5	OUT	Output	Output for driving a power MOSFET
6	VCC	Power supply	Power supply
7	REF	Reference voltage	Reference voltage output (5V)
8	CS	Soft-start and ON/OFF control	Soft-start, ON/OFF function and latch-mode shutdown operations

6. Ratings and Characteristics

Current characteristics; "+" is sink current and "-" is source current

(1) Absolute maximum ratings

Item	Symbol	Rating	Unit	
Supply Voltage	Low impedance source (ICC>15mA)	VCC1	30	V
	Internal zener clamp voltage (ICC<15mA)	VCC2	Self Limiting	V
OUT pin peak current	Sink current	IOL	+1.0	A
	Source current	IOH	-0.5	A
FB pin input voltage	VFB	-0.3 to 5.0	V	
IS pin input voltage	VIS	-0.3 to 5.0	V	
REF pin source current	IREF	-10	mA	
CS pin sink current	ICS	+2.0	mA	
Total power dissipation (Ta=25°C)	Pd	800 (DIP-8) 400 (SOP-8)	mW	
Ambiant temperature	Ta	-30 to +85	°C	
Maximum junction temperature	Tj	125	°C	
Storage temperature	Tstg	-40 to +150	°C	

※Maximum power dissipation curve

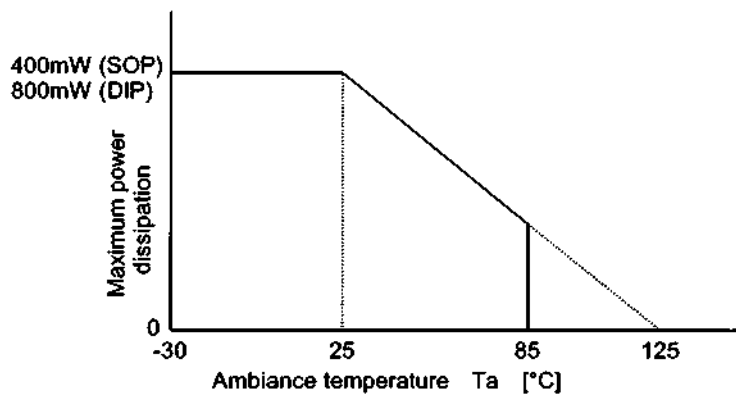

(2) Recommended operating conditions

Item	Symbol	MIN.	TYP.	MAX.	Unit
Supply voltage	Voc	10		28	V
REF-GND capacitor	Cref	0.1	0.47		uF
Soft start capacitor	Cs	0.01		1	uF
Oscillation frequency (FB>1.2V)	fosc	30		500	kHz
Minimum oscillation frequency at light-load mode (FB<1.2V)	foscL	10			kHz

(3) Electrical characteristics (VCC=18V,RT=47kΩ,Ta=25°C, unless otherwise noted)

Reference voltage section (REF)

Item	Symbol	Condition	MIN.	TYP.	MAX.	Unit
Reference voltage	VREF	Tj=25°C	4.75	5.00	5.25	V
Voltage variation1 (Line regulation)	Vdv	VCC=10 to 28V		±6	±20	mV
Voltage variation2 (Load regulation)	Vdv	IL=0 to 10mA VCC=18V		±6	±20	mV
Voltage variation3 (Temperature stability)	VdT	Ta=30 to 85°C		±0.5		mV/°C

Oscillator section (RT)

Item	Symbol	Condition	MIN.	TYP.	MAX.	Unit
Oscillation frequency	fOSC	RT=47kΩ, Tj=25°C	92.6	100	107.4	kHz
Frequency variation1 (Voltage stability)	fdv	VCC=10 to 28V		±1.6		%
Frequency variation2 (Temperature stability)	fdT	Ta=30 to 85°C		±0.02		%/°C

Pulse width modulation circuit section

Item	Symbol	Condition	MIN.	TYP.	MAX.	Unit
FB pin source current	IFB	VFB=0V	-985	-750	-615	uA
Input threshold voltage (FB pin)	VTHFB0	Duty cycle=0%	0.95	1.03		V
	VTHFBM	Duty cycle=DMAX		2.40		V
Maximum duty cycle	DMAX	FB=2.5V	66	70	74	%

Reducing oscillation frequency section (FB)

Item	Symbol	Condition	MIN.	TYP.	MAX.	Unit
FB pin Input threshold voltage	VTHFBS			1.18		V
Frequency reduction	kfS1	FB=1.10V to 1.15V		16.7		kHz
Minimum oscillation frequency	foscS2			46		kHz

Overcurrent limiting circuit section (IS)

Item	Symbol	Condition	MIN.	TYP.	MAX.	Unit
Input threshold voltage (IS pin)	VTHIS	FA3641P/N	215	235	255	mV
		FA3647P/N	-190	-170	-150	
Source current (IS pin)	IIS	VIS=0V FA3641MP FA3647P/N		-20	-5	uA
Delay time	tpdIS			150		ns

Soft start circuit section (CS)

Item	Symbol	Condition	MIN.	TYP.	MAX.	Unit
Charge current (CS pin)	ICHG	VCS=1V, Tj=25°C	-4.0	-6.5	-9.0	uA
Input threshold voltage (CS pin)	VTHCS0	Duty cycle=0%	0.95	1.03		V
	VTHCSM	Duty cycle=DMAX		2.40		V

Output ON/OFF control circuit section (CS)

Item	Symbol	Condition	MIN.	TYP.	MAX.	Unit
Source current (CS pin)	IS0CS	VCS=0V, Tj=25°C	-4.0	-6.5	-9.0	uA
ON/OFF control threshold voltage (CS pin)	VTHON	OFF → ON Tj=25°C		0.82	0.95	V
	VTHOF	ON → OFF Tj=25°C	0.50	0.68		V

Latch-mode cutoff circuit section (CS)

Item	Symbol	Condition	MIN.	TYP.	MAX.	Unit
Sink current (CS pin)	ISICS	VCS=6.5V, VFB=1V Tj=25°C	20	35	50	µA
Cutoff threshold voltage (CS pin)	VTHCSF	ON → OFF Tj=25°C	8.0	8.5	9.0	V
	VTHCSN	OFF → ON Tj=25°C	7.4	7.9	8.4	V
Hysteresis voltage	VTHHS			0.6		V

Overload cutoff circuit section (FB)

Item	Symbol	Condition	MIN.	TYP.	MAX.	Unit
Cutoff-state threshold voltage (FB pin)	VTHFB		2.8	3.0	3.3	V

Overvoltage cutoff circuit section (VCC)

Item	Symbol	Condition	MIN.	TYP.	MAX.	Unit
Cutoff threshold voltage (VCC pin)	VTHVCC	Tj=25°C	30	32	34	V
Cutoff-state supply current (VCC pin)	IVCC	Tj=25°C		13		mA
Charge current (CS pin)	IS0CS2	VCS=6.5V	-0.5	-0.9	-1.4	mA

Undervoltage Lockout circuit section (VCC)

Item	Symbol	Condition	MIN.	TYP.	MAX.	Unit
OFF-to-ON threshold voltage	VCCON	Tj=25°C	15.5	16.5	17.5	V
ON-to-OFF threshold voltage	VCCOFF	Tj=25°C	8.5	9.0	10.0	V
Hysteresis voltage	VHYS	Tj=25°C	6.8	7.5	8.2	V

Output circuit section (OUT)

Item	Symbol	Condition	MIN.	TYP.	MAX.	Unit
Low output voltage	VOL	IOL=100mA		0.7	1.5	V
High output voltage	VOH	IOH=100mA, VCC=18V	15	16.5		V
Rise time	tr	OUT=1000pF		50		ns
Fall time	tf	OUT=1000pF		40		ns

supply current (VCC)

Item	Symbol	Condition	MIN.	TYP.	MAX.	Unit
Stand-by current	ICCSTB	VCC=14V			2	µA
Starting-up current	ICCST	VCC=start threshold		12	30	µA
Operating-state supply current	ICCOP	No load		1.9	2.5	mA
OFF-state supply current	ICCOF	VCC=17V, CS=0V		100		µA
Cutoff-state supply current	ICCL	VCC=10V		45	100	µA

7.Characteristics curves

Current characteristics; "+" is sink current and "-" is source current

Oscillation frequency(f_{osc}) vs. timing resistor resistance(R_t)

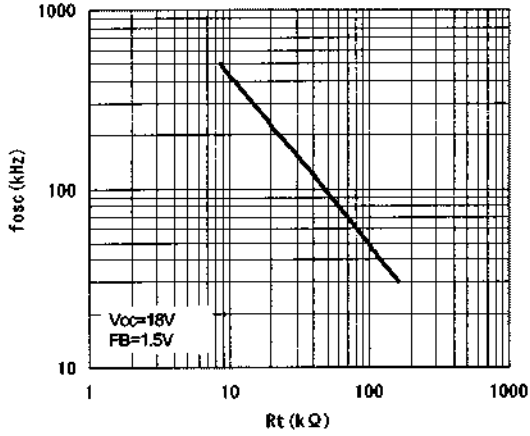

Oscillation frequency (f_{osc}) vs. supply voltage (V_{cc})

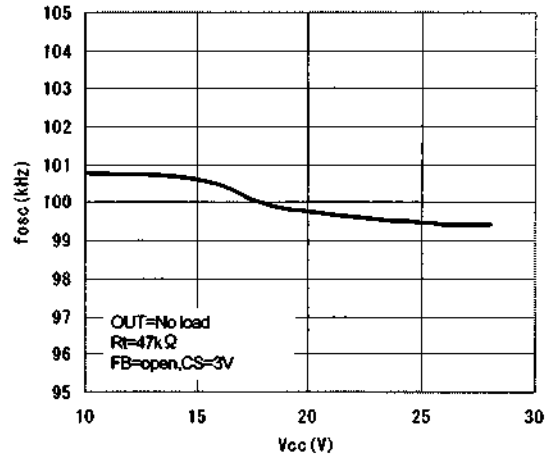

Oscillation frequency (f_{osc}) vs. junction temperature (T_j)

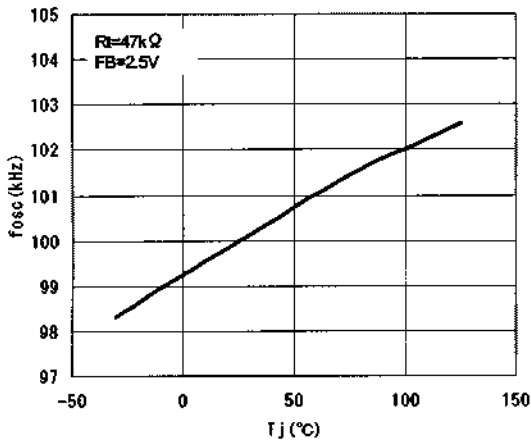

L-level output voltage (V_{oL}) vs. supply voltage (V_{cc})

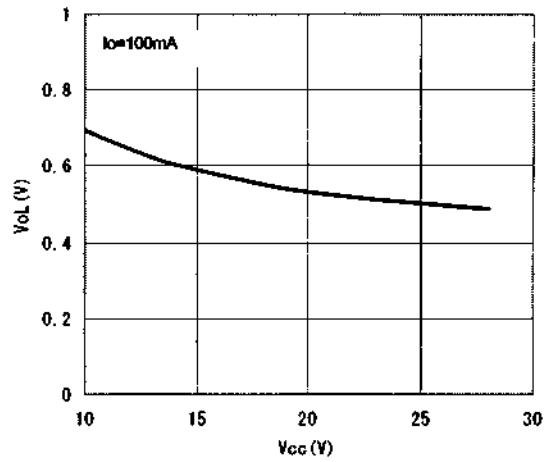

Supply current (I_{cc}) vs. supply voltage (V_{cc})

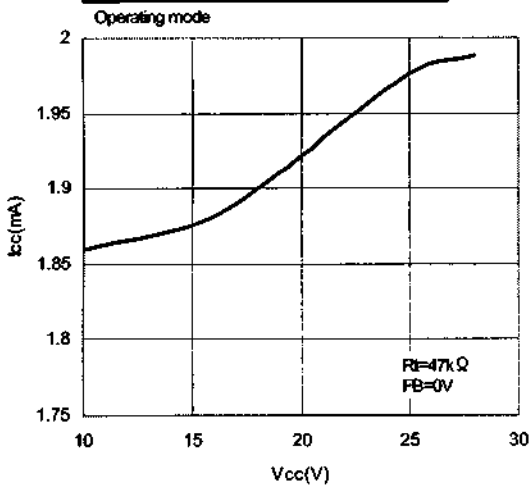

Supply current (I_{cc}) vs. junction temperature (T_j)

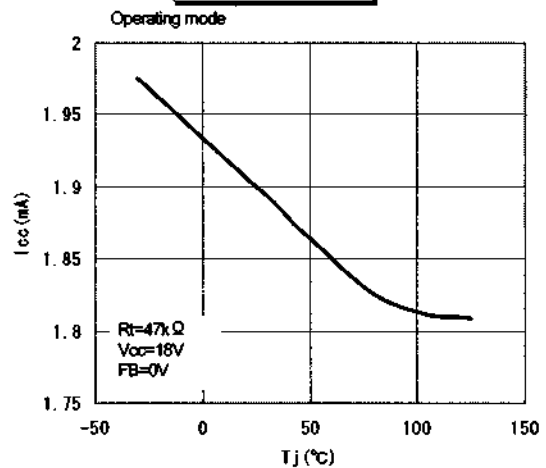

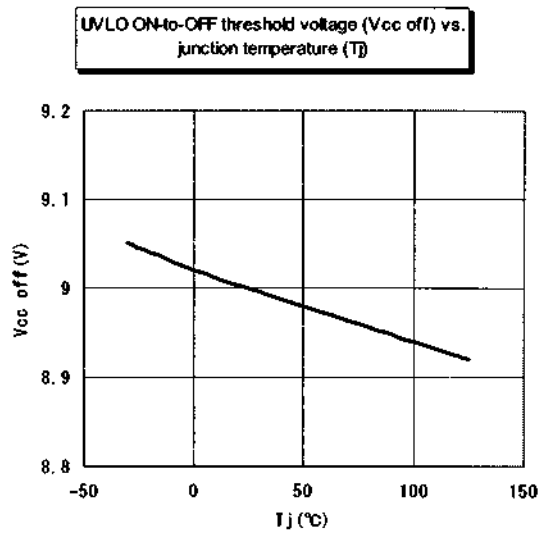
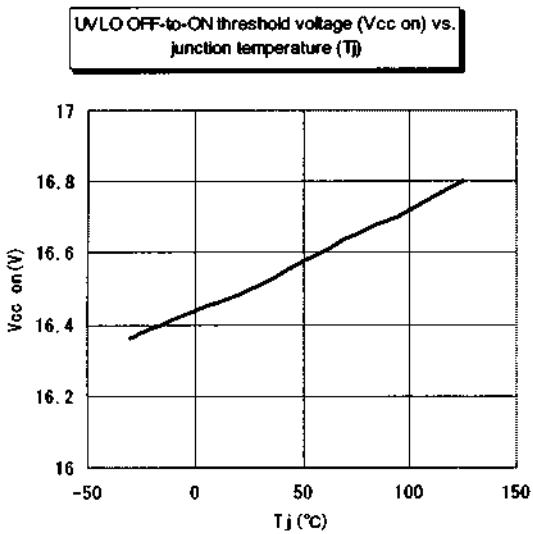
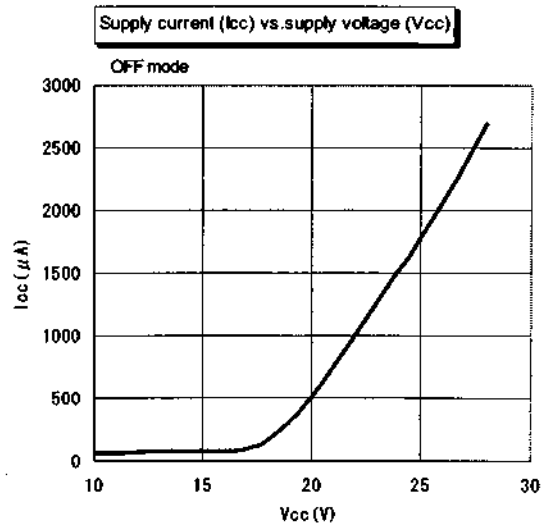
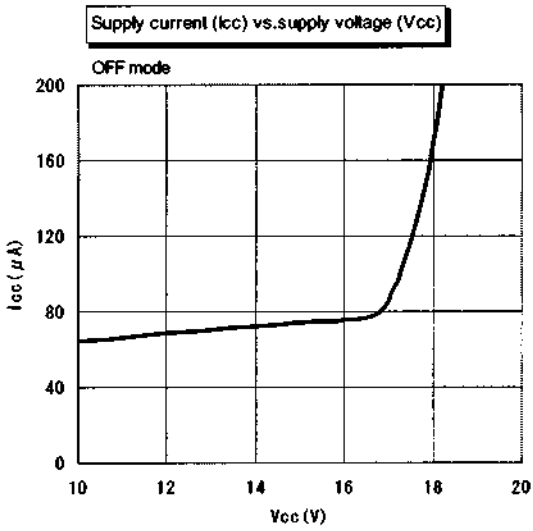
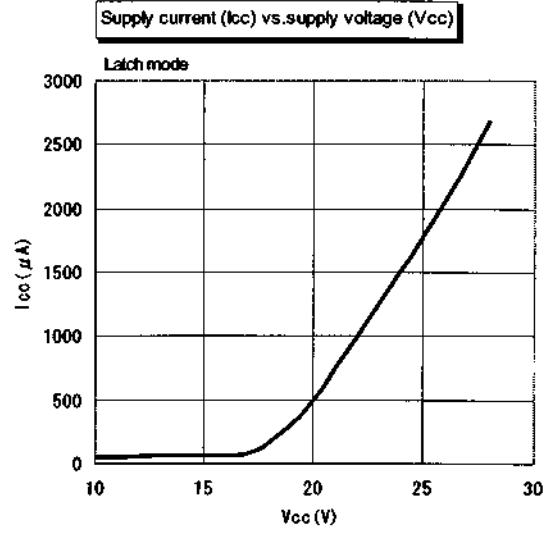
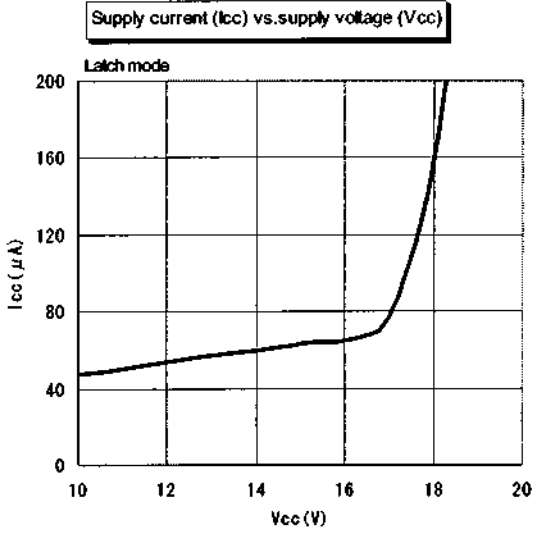

CS terminal current (Ics) vs. CS terminal voltage (Vcs)

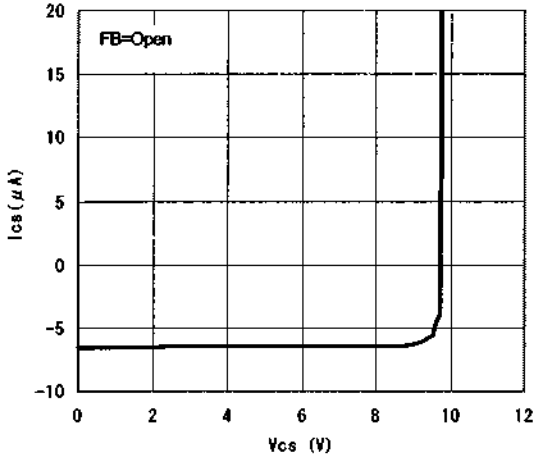

CS terminal current (Ics) vs. CS terminal voltage (Vcs)

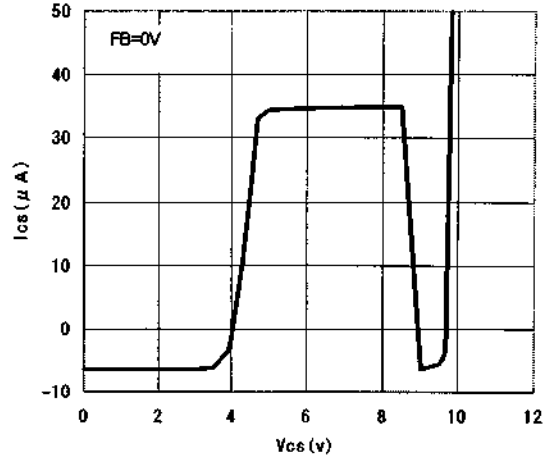

CS terminal charge current (Ichg) vs. junction temperature (Tj)

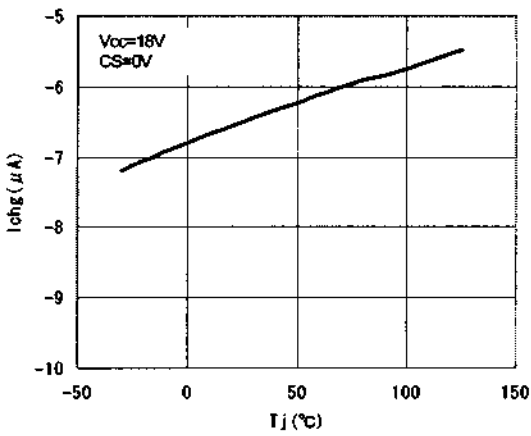

FB terminal source current (IFB) vs. FB terminal voltage (VFB)

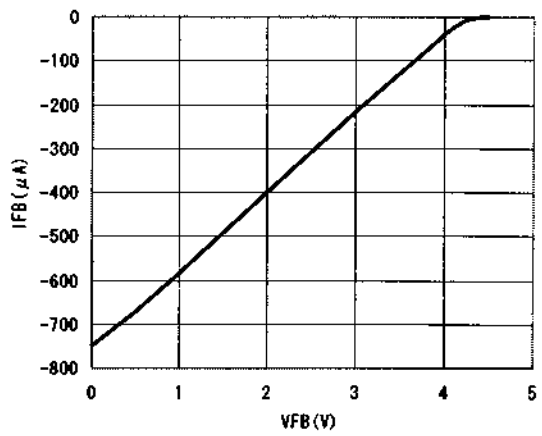

IS(+) terminal current (IIS(+)) vs. IS(+) terminal voltage (VIS(+))

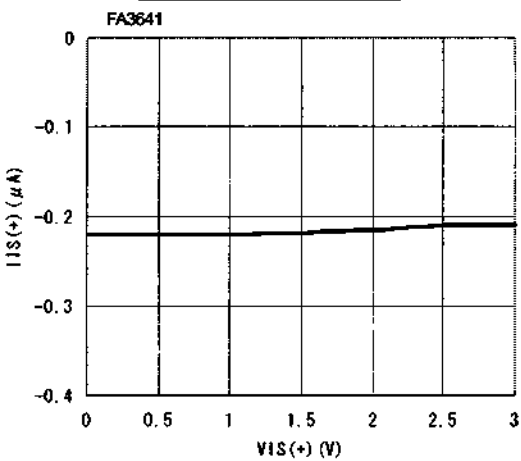

IS(-) terminal current (IIS(-)) vs. IS(-) terminal voltage (VIS(-))

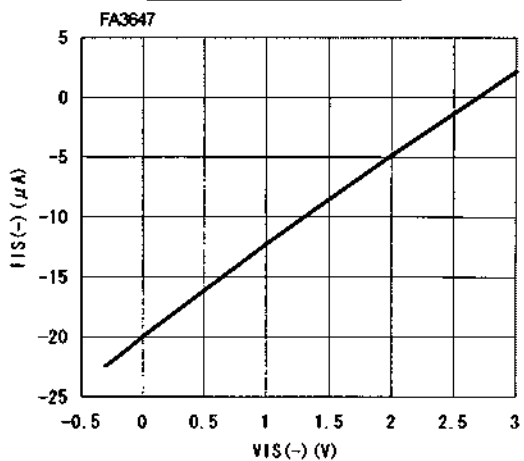

8. Description of each circuit

(1) Oscillator

The oscillator generates a triangular waveform by charging and discharging the built-in capacitor. A desired oscillation frequency can be set by the value of the resistor connected to the RT pin (Figure 1).

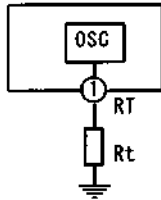

Fig.1 Oscillator

The built-in capacitor voltage oscillates between about 3V and 1V, with almost the same charging and discharging gradients (Figure 2). You can set the desired oscillation frequency by changing the gradients using the resistor connected to the RT pin. (Large R_t = low frequency, small R_t = high frequency) The oscillation frequency is automatically lowered when output duty cycle is small ($FB \leq$ about 1.18V) in light load mode. For more information, see item (2), "Reducing oscillation frequency circuit in light-load mode"

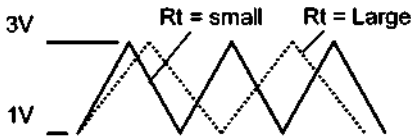

Fig.2 Oscillator output

The relationship between R_t and the fixed oscillation frequency is approximately given by:

$$f_0 \text{ [kHz]} \approx \frac{4880}{R_t + 1.4} \dots\dots\dots (1)$$

$$R_t \text{ [k}\Omega\text{]} \approx \frac{4880}{f_0} - 1.4 \dots\dots\dots (2)$$

Where f_0 is the fixed frequency [kHz] and R_t is timing resistance [k Ω].

The oscillator waveform cannot be observed from the outside because a pin for this purpose is not provided. The oscillator output is connected to a PWM comparator. The RT pin is 2.5V DC in normal fixed frequency operation mode. When the frequency is lowered, the voltage also decreases linearly to about 1V.

(2) Reducing oscillation frequency circuit in light-load mode

To reduce the loss of the power supply in standby mode, this IC has a feature that automatically lowers the oscillation frequency when the load is light.

When the load is light, with the result that the IC output pulse width narrows below about 10% and the FB pin voltage decreases below about 1.18V, the oscillation frequency begins to decrease linearly until the output pulse width becomes 0. When the output pulse width is 0, the oscillation frequency is about 46% of normal fixed frequency. (Figure 3). Even while the oscillation frequency is decreasing, the built-in capacitor voltage oscillates between about 3V and 1V.

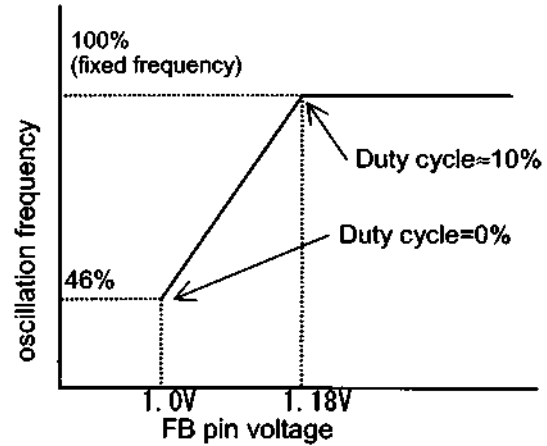

Fig.3 Oscillation frequency

The frequency reduction rate (46%) can be adjusted from the outside. (See Section 9, "Design advice," for more information.)

(3) PWM comparator

The PWM comparator has four inputs as shown in Figure 4. Oscillator output ① is compared with CS pin voltage ②, FB pin voltage ③, and DT voltage ④. The lowest of three inputs ②, ③, and ④ has priority and is compared with output ①. While the voltage is lower than the oscillator output, the comparator output is high. While the voltage is higher than the oscillator output, the PWM comparator output is low (see figure 5). The IC OUT pin voltage is high while the PWM comparator output is low.

When the IC is powered up, CS pin voltage ② controls soft start operation. The output pulse then begins to widen gradually. During normal operation, the output pulse width is determined within the maximum duty cycle (70%) set by DT voltage ④ under the condition set by FB pin voltage ③, to stabilize the output voltage.

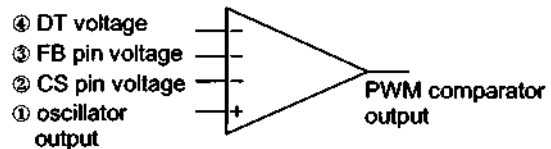

Fig.4 PWM comparator

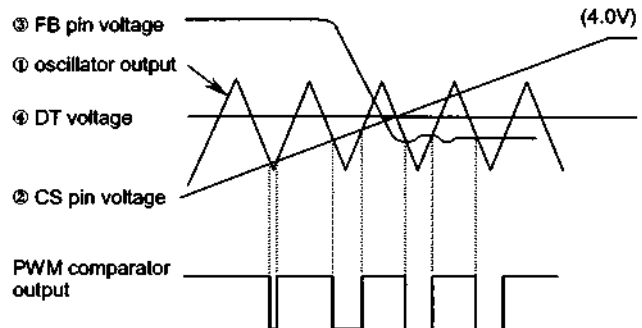

Fig.5 PWM comparator timing chart

(4) CS pin circuit

As shown in Figure 6, capacitor C_s is connected to the CS pin. The CS pin voltage varies depending on the charging voltage of this capacitor C_s . When the power is turned on, the constant current source ($6.5\mu\text{A}$) begins to charge capacitor. Accordingly, the CS pin voltage rises as shown in Figure 7. The CS pin voltage is connected to the PWM comparator, which is characterized to make output based on the lowest of input voltages. The device enters soft-start mode while the CS pin voltage is between 1.0V and 2.4V. During normal operation, the CS pin is clamped at 4.0V by internal zener diode.

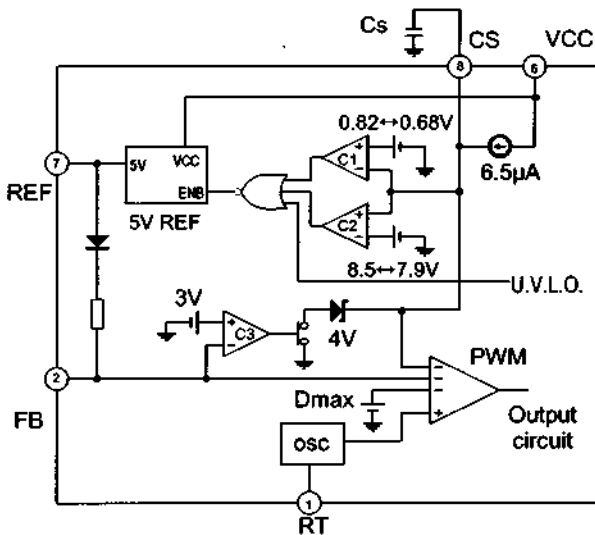

Fig.6 CS pin circuit

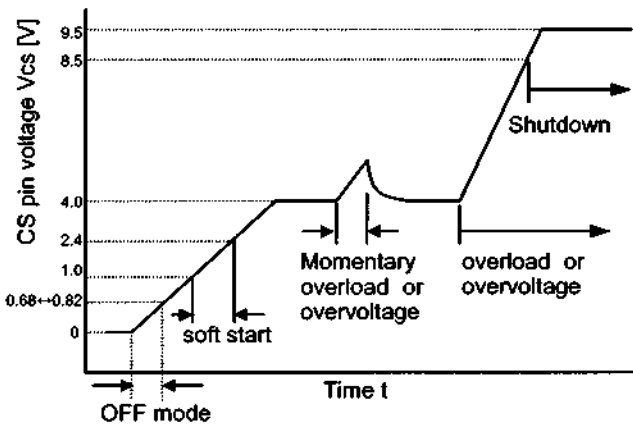

Fig.7 CS pin waveform

If the output voltage drops due to an overload and the FB voltage rises to 3V or more, the clamp voltage 4.0V is canceled and the CS pin voltage rises to 9.5V. The CS pin is also connected to latch comparator C2. If the CS pin voltage rises to 8.5V or more, comparator C2 toggles to turn off the 5V REF circuit, thereby shutting the output down. Since the CS pin is also connected to comparator C1, the 5V REF circuit can be turned off to shut the output down by dropping the CS pin voltage below 0.68V. In this way, comparator C1 can be used for output on-off control.

As explained above, the CS pin can be used for soft-start, overload output shutdown and output on-off control by varying the voltage. Further details on the above three major functions of the CS pin are given below.

(i) Soft start function

Figure 8 shows the soft start circuit. Figure 9 is a soft-start operation timing chart. The CS pin is connected to capacitor C_s . When the power is turned on, the constant current source ($6.5\mu\text{A}$) begins to charge the capacitor. As shown in the timing chart, the CS pin voltage rises slowly in accordance with the capacitor C_s charging current. The CS pin is also connected to the IC internal PWM comparator, which has such characteristics that the voltage is determined to output on the basis of the lowest of input voltages. The comparator output pulse slowly widens to cause a soft start as shown in the timing chart.

The soft start period can be approximately estimated by the period t_s , from the time the IC is activated to the time the output pulse width widens to 30%. The period is given by the following equation:

$$t_s [\text{ms}] \approx 250 \times C_s \dots (3)$$

Where C_s is the soft start capacitor [μF]

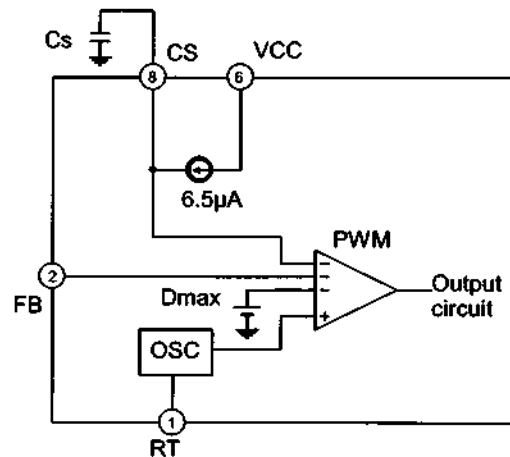

Fig.8 Soft-start circuit

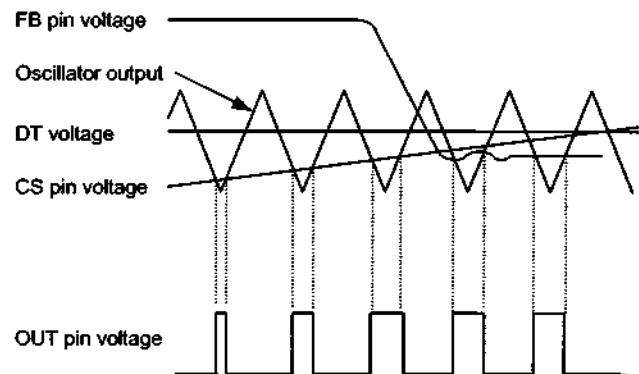

Fig.9 Soft-start timing chart

(ii) Overload shutdown function

Figure 10 shows the overload shutdown circuit, and Figure 11 is a timing chart that illustrates overload shutdown operation.

If the output voltage drops due to an overload or short circuit, the FB pin output voltage rises. If the FB pin voltage exceeds the reference voltage (3.0) of comparator C3, the output of comparator C3 goes low to turn off the switch. With the switch off, the CS pin voltage clamped at 4.0V by zener diode in normal operation is unclamped, and the constant current source ($6.5\mu\text{A}$) begins to charge capacitor C_s again and the CS pin voltage rises. When

the CS pin voltage exceeds the reference voltage (8.5V) of comparator C2, the output of comparator C2 toggles to turn off the 5V REF circuit. The IC then enters the latched mode and shuts down the output. IC current consumption for shutdown is 45 μ A (typ) ($V_{CC} = 10V$). This current must be supplied through the startup resistor. The IC enters output off (low voltage) state. The overload shutdown operation can be reset by lowering the supply voltage V_{CC} to below the OFF threshold voltage (9.0V) or forcing the CS pin voltage below 7.9V.

The period t_{CS} from the time the output is short-circuited to the time the output circuit goes off is given by the following equation:

$$t_s [\text{ms}] = 690 \times C_s \dots\dots (4)$$

Where C_s is the soft start capacitor [μ F]

When you want to disable the overload shutdown function, see item (10) in Section 9, "Design advice."

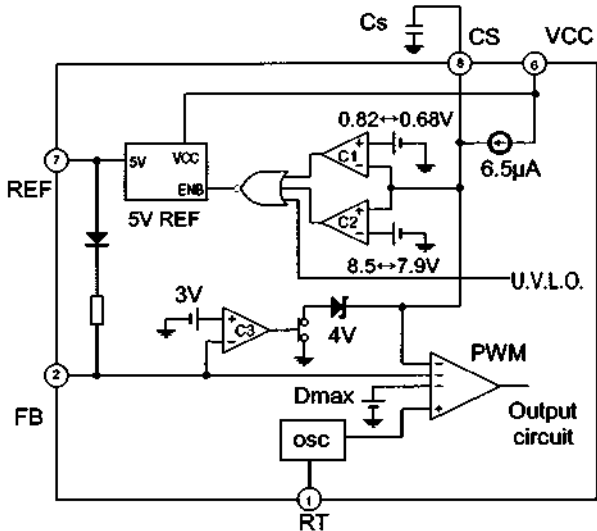

Fig.10 Overload shutdown circuit

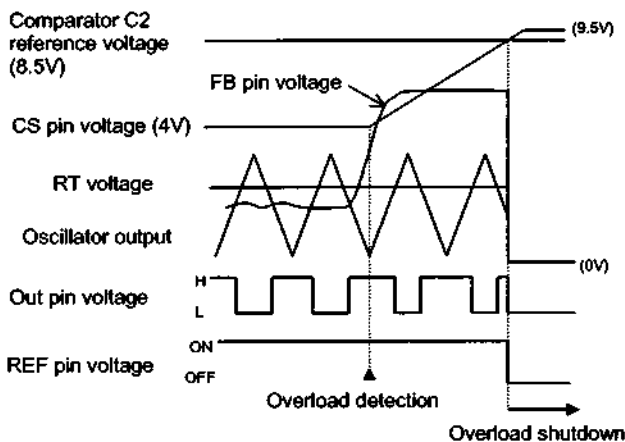

Fig.11 Overload shutdown timing chart

(iii) Output on-off control function

The IC can be turned on or off via an external signal applied to the CS pin. Figure 12 shows the output on-off control circuit, and Figure 13 is a timing chart.

The IC is turned off when the CS pin voltage is externally made to drop below 0.68V (typ). The output of comparator C1 goes high

to turn the 5V REF circuit. This shuts the output down. The IC enters output off (low voltage) state. Required IC current consumption during shutdown is 100 μ A (typ) ($V_{CC} = 17V$). This current must be supplied through the startup resistor. The IC goes on when the CS pin is opened and the CS pin voltage exceeds 0.82V (typ). This turns on the 5V REF circuit and results in automatic soft start. The power supply then restarts operation.

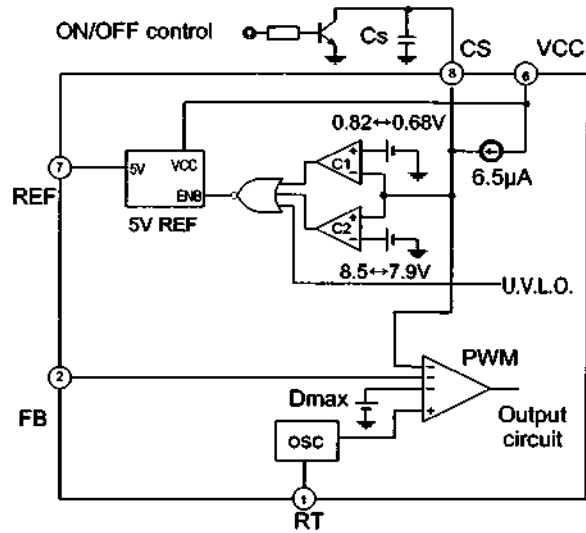

Fig.12 External output ON/OFF control circuit

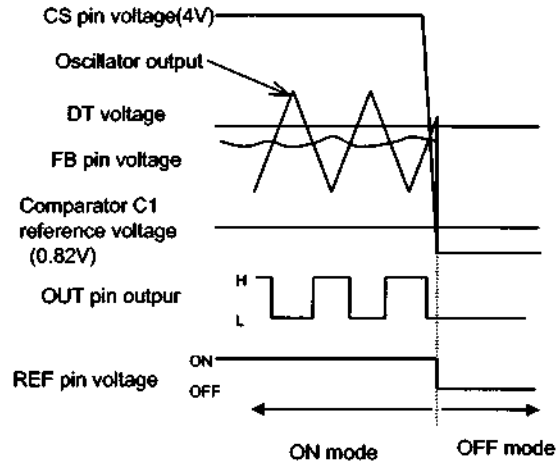

Fig.13 Output ON/OFF control circuit timing chart

(5) Overcurrent limiting circuit

The overcurrent limiting circuit detects the peak value of every drain current pulse (pulse by pulse method) of the main switching MOSFET to limit the overcurrent. The detection threshold voltage is +0.235V for FA3641 or -0.17V for FA3647 with respect to the ground as shown in Figure 14.

The drain current of the MOSFET is converted to voltage by resistor R_s and fed to the IS pin of the IC. If the voltage exceeds the reference voltage +0.235V (FA3641) or -0.17V (FA3647) of comparator C4, comparator C4 works to set flip-flop output Q to high. The output is immediately turned off to shut off the current. Flip-flop output Q is reset on the next cycle to turn on the output again. This operation is repeated to limit the overcurrent.

If the overcurrent limiting circuit malfunctions due to noise, place an RC filter between the IS pin and MOSFET as shown in Figure 14. (See (14) in Section 9, "Design Advice.")

Figure 15 is a timing chart that illustrates current-limiting operations.

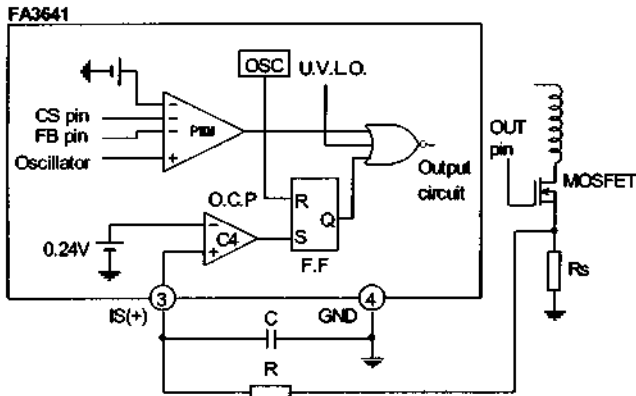

Fig.14 Overcurrent limiting circuit

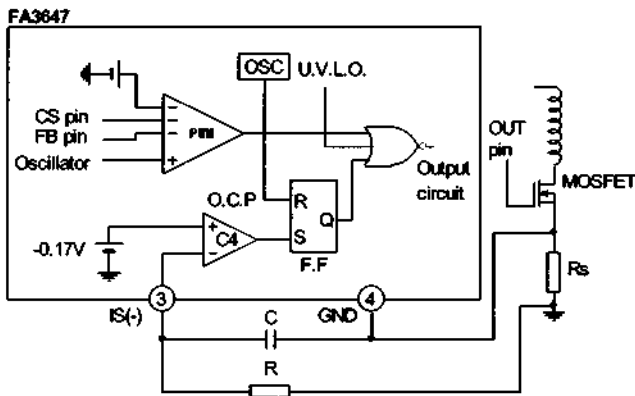
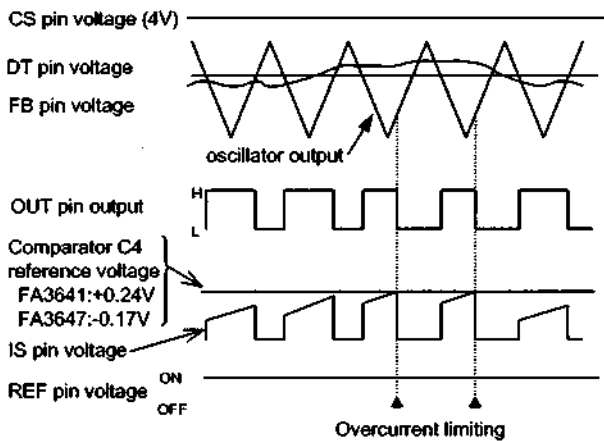

Fig.15 Overcurrent timing chart



(6) Vcc overvoltage protection circuit

The IC contains a Vcc overvoltage protection circuit to protect the damage by overvoltage. Figure 16 shows the overvoltage protection circuit. Figure 17 is a timing chart that illustrates overvoltage protection operations.

Overvoltage is detected if the supply voltage Vcc rises to 32V (Ioc = 13mA) or more and current flows in the built-in zener diode. The output of comparator C5 then goes high and the constant current source (0.9mA) raises the CS pin voltage. When the CS pin voltage exceeds 8.5V, the output of comparator C2 goes high to turn off the 5V REF circuit. The IC then enters the latched mode and the IC output is put in the off (low voltage) state. When latched mode, the IC current consumption is 45µA (typ) (Vcc =

10V). This current must be supplied through the startup resistor. The overvoltage shutdown operation can be reset by lowering the supply voltage to below 9.0V or forcing the CS pin voltage below 7.9V.

(When you want to enable Vcc overvoltage shutdown at a desired voltage, see item (6) in Section 9, "Design advice.")

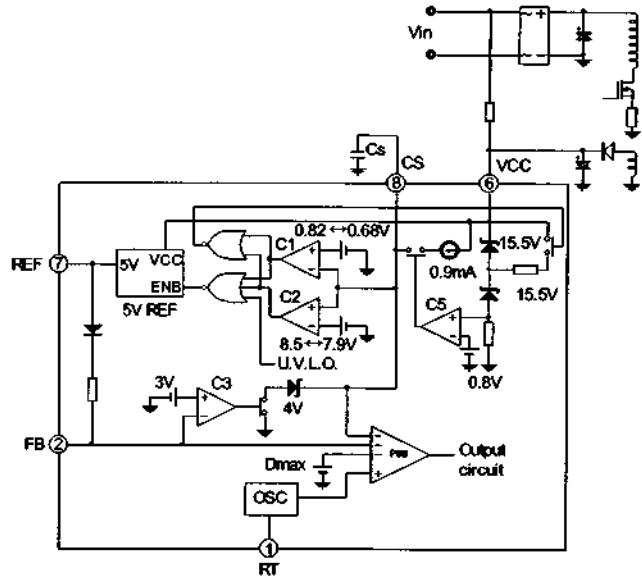

Fig.16 Overvoltage shutdown circuit

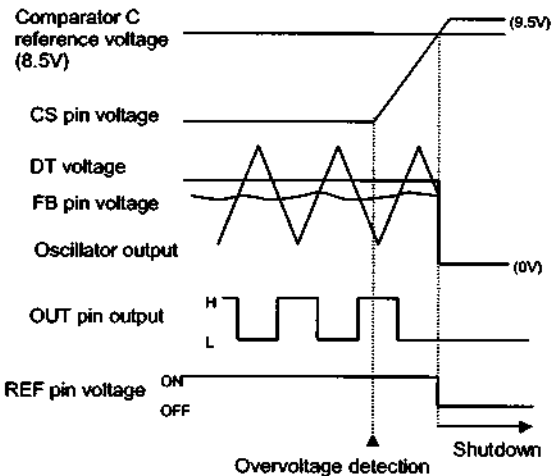

Fig.17 Overvoltage shutdown timing chart

(7) Undervoltage lockout circuit (U.V.L.O.)

The IC incorporates a circuit that prevents the IC from malfunctioning when the supply voltage drops. When the supply voltage is raised from 0V, the IC starts operation with Vcc = 16.5V (typ). If the supply voltage drops, the output is shut down when Vcc = 9.0V (typ). When the undervoltage lockout circuit operates, the outputs of the OUT and CS pins go low to reset the IC.

(8) Output circuit

The IC contains a push-pull output stage and can directly drive the MOSFET. The maximum peak current of the output stage is a sink current of 1A and a source current of 0.5A. If the circuit operation stops when the undervoltage lockout circuit operate, the OUT pin voltage goes low to shut down the MOSFET.

9. Design advice

(1) Externally setting the oscillation frequency in the light-load mode

As explained in (2) in Section 8, "Description of Each Circuit," the IC has a function that automatically lowers the oscillation frequency when the load is light to reduce the loss of the power supply in standby mode. The oscillation frequency goes down to about 46% without adjustment by external circuit.

To further lower the frequency below 46%, connect adjustment resistor R_r between the RT and the REF pins as shown in Figure 18. Then the fixed frequency determined by R_t also falls.

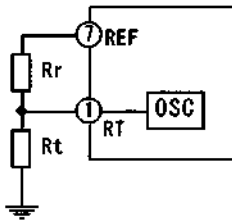

Fig.18 Oscillator circuit

The relationship between the external resistance and oscillation frequency is outlined below:

$$R_t [\text{k}\Omega] \approx \frac{2.35}{3.35A - B} \quad R_r [\text{k}\Omega] \approx \frac{2.35}{A - B} \quad \dots (5)$$

$$f_0 [\text{kHz}] \approx \frac{4880}{\frac{R_t R_r}{R_r - R_t} + 1.4} \quad f_r [\text{kHz}] \approx \frac{2500}{\frac{R_t R_r}{R_r - 3.35 R_t} + 6} \quad \dots (6)$$

Where:

f_0 : Fixed frequency [kHz]

f_r : Minimum frequency in variable mode [kHz]

R_t : Timing resistor [k Ω]

R_r : Adjustment resistor [k Ω]

$$A = \frac{f_0}{4880 - 1.4 f_0} \quad B = \frac{f_r}{2500 - 6 f_r}$$

Select R_t and R_r so that the relationship between the two satisfies the following:

- $R_t < 0.3 R_r \dots (7)$
- Set the minimum frequency in light-load mode to 10 kHz or more.

Failure to keep the above relationship may disturb the operation.

Note that the above expressions determine approximate values. Note also that the minimum frequency in light-load mode depends on such conditions as the power supply efficiency. Therefore, check the operation using a practical circuit to make a final decision.

(Calculation example)

To set the fixed frequency $f_0 = 100\text{kHz}$ and the minimum frequency in light-load mode to $f_r = 20\text{kHz}$, the following can be obtained from expressions (5).

$$R_t \approx 37.7 [\text{k}\Omega] \quad R_r \approx 185.1 [\text{k}\Omega]$$

Decrease R_r to permit the frequency to vary in a wider range.

(2) Deciding the startup circuit

These ICs, which uses CMOS process, consume less current, and therefore can use larger startup resistance than the conventional bipolar type of IC.

To decide the startup resistance, the following conditions must be satisfied:

- (a) The IC is started when the power is turned on.
- (b) The IC consumption current is supplied during latch mode operation to maintain the latch state.
- (c) The IC consumption current is supplied during the off state under the on-off function to maintain the off state.

However, these are the minimum conditions for using the IC. The startup time required for a power supply must also be decided on.

(i) Connecting a startup resistor before rectification (AC line)

When the startup resistor is connected before rectification (AC line) as shown in Figure 19, the voltage applied to the startup resistor forms a half-wave rectified waveform of the AC input voltage.

Startup resistor R_1 must satisfy the three equations shown below. Select a smaller-side value for R_1 in consideration of the temperature characteristics.

- (a) To supply startup current $30\mu\text{A}$ at ON threshold voltage 17.5V (max.) of UVLO:

$$R_1 [\text{k}\Omega] = \frac{\frac{\sqrt{2}}{\pi} \times V_{ac} - 17.5}{0.03} \quad \dots (8)$$

- (b) To supply IC consumption current $100\mu\text{A}$ (max.) ($V_{cc} = 10\text{V}$) in latch mode:

$$R_1 [\text{k}\Omega] = \frac{\frac{\sqrt{2}}{\pi} \times V_{ac} - 10}{0.1} \quad \dots (9)$$

- (c) To supply IC consumption current $200\mu\text{A}$ (max.) ($V_{cc} = 17\text{V}$) in the off state under the on-off function:

$$R_1 [\text{k}\Omega] = \frac{\frac{\sqrt{2}}{\pi} \times V_{ac} - 17}{0.2} \quad \dots (10)$$

Where;

R_1 : Startup resistance [k Ω]

V_{ac} : Effective value of AC input voltage [V]

If neither the latch mode operation nor the on-off functions are used, only the expression in (8) needs to be satisfied.

In this method, the supply current to the IC via the start-up resistor is stopped when AC input is shut down. Therefore, after latch mode operation, shutting the AC input down resets the latch mode in a very short period of time.

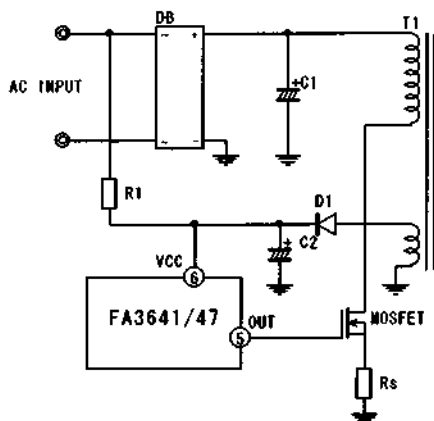

Fig.19 Startup circuit (1)

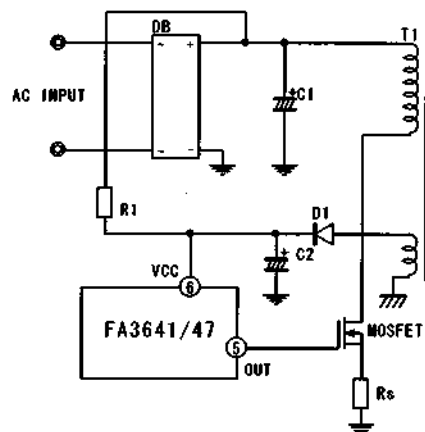

Fig.20 Startup circuit (2)

(ii) Connecting the startup resistor after rectification (DC line)

When the startup resistor is connected after rectification (DC line) as shown in Figure 20, the voltage applied to the startup resistor becomes the peak value of the AC input voltage. Startup resistor R1 must satisfy the three equations shown below. Select a smaller-side value for R1 in consideration of temperature characteristics.

- (a) To supply startup current 30μA at ON threshold voltage 17.5V (max.) of UVLO:

$$R1[k\Omega] = \frac{\sqrt{2} \times V_{ac} - 17.5}{0.03} \dots\dots\dots (11)$$

- (b) To supply IC consumption current 100μA (max.) (Vcc = 10V) in shutdown or OFF mode:

$$R1[k\Omega] = \frac{\sqrt{2} \times V_{ac} - 10}{0.1} \dots\dots\dots (12)$$

- (c) To supply IC consumption current 200μA (max.) (Vcc = 17V) in the off state under the on-off function:

$$R1[k\Omega] = \frac{\sqrt{2} \times V_{ac} - 17}{0.2} \dots\dots\dots (13)$$

Where:

R1: Startup resistance [kΩ]

Vac: Effective value of AC input voltage [V]

If neither the latch nor the on-off functions are used, only the expression in (11) needs to be satisfied.

In this method, after latch mode operation, smoothing capacitor C1 in the main circuit supplies current to the IC via the startup resistor even if the AC input is shut down. Therefore, some time must elapse before the latch mode is reset.

(3) Determining the Vcc capacitor value

To properly start the power supply, a certain value is required for the capacitor connected to the VCC pin. Figure 21 shows the Vcc voltage at start-up when a proper value is given to the capacitor.

When the input power is turned on, the capacitor connected to the VCC pin is charged via the startup resistor and the voltage increases. The IC is then in standby state and almost no current is consumed. (Icc < 2μA)

Thereafter, Vcc reaches the ON threshold voltage of UVLO and the IC begins operation.

When the IC begins operation to make output, the IC operates based on the voltage from the auxiliary winding. When the IC is just starting up, however, it takes time for the voltage from the auxiliary winding to rise enough, and Vcc drops during this period.

Determine the Vcc capacitor value so that Vcc will not drop down to the OFF threshold voltage of UVLO during this period.

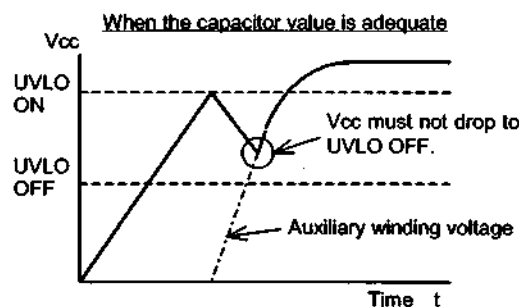

Fig.21 Vcc voltage at startup with a adequate capacitor

If the Vcc capacitor value is too small, Vcc will drop to the OFF threshold voltage of UVLO before the auxiliary winding voltage rises enough. If so, Vcc repeatedly goes up and down between the UVLO threshold voltages, and the power supply cannot start up. (Figure 22)

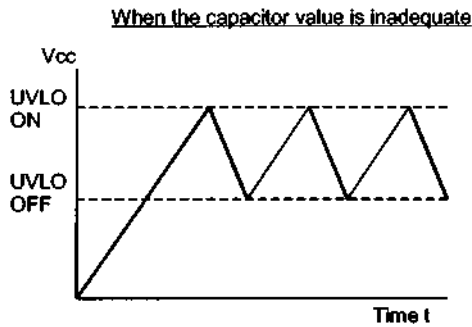

Fig.22 Vcc voltage at startup with a inadequate capacitor

(4) Shortening the startup period

Increasing the resistance of the startup resistor to reduce loss prolongs the startup period. Figure 23 shows a circuit for shortening the startup period. The C2 capacitance is decreased to shorten the startup period and, after the IC starts up, power is supplied from C3.

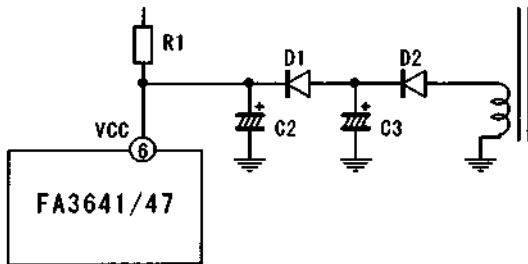

Fig.23 startup circuit (3)

(5) Setting soft start period and OFF latch delay independently

Figure 24 shows a circuit for setting the soft start period and OFF latch delay independently. In this circuit, capacitance CS determines the soft start period, and capacitance CL determines the OFF latch delay.

If the overload shutdown or overvoltage shutdown functions raise the CS pin voltage to around 5V, zener diode Zn becomes conductive to charge capacitor CL. The OFF latch delay can be thus prolonged by capacitance CL.

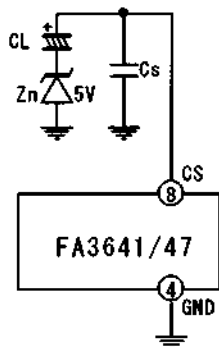

Fig.24 Independent setting of soft start period and OFF latch delay

(6) Overvoltage protection using the VCC pin

This IC contains an overvoltage protection function detecting the Vcc voltage using internal ZD (see item (7) in Section 8, "Description of each circuit"). If Vcc voltage exceeded about 32V, the current of 13mA flows through the internal ZD and the overvoltage protection function operates.

After this protection function operates, the IC continues to consume the large current if high voltage continues to be applied to the Vcc pin. Mind that total IC loss does not exceed the rating.

If the voltage source applied to Vcc pin has relatively high impedance and cannot source the current of 13mA, overvoltage protection function does not operate. But the internal ZD maintains the Vcc voltage 32V or less and protects the IC.

(7) Overvoltage protection using CS pin

These ICs contains the overvoltage protection function detecting Vcc voltage. However, the threshold voltage of the function is fixed. Adding some circuit to CS pin enables the overvoltage protection detecting desired voltage.

(i) Detecting on secondary side

Figure 25 shows the overvoltage shut down circuit based on the signal from the secondary side. The optocoupler output transistor is connected between the CS and Vcc pins. When the output voltage is put in the overvoltage state, The optocoupler output transistor goes on to rise the CS pin voltage via resistor R2. When the CS pin voltage exceeds the reference voltage (8.5V) of comparator C2, the output of the comparator C2 goes high to turn off the 5V REF circuit. Accordingly, the IC enters the OFF latch mode and shuts the output down. The IC consumes current 45µA (typ) (Vcc = 10V) in latch mode. This current must be supplied via startup resistor R1.

The overvoltage protection circuit can be reset by lowering the supply voltage Vcc to below 9.0V or forcing the CS pin voltage below 7.9V.

In normal operation, the CS pin voltage is clamped by the 4V zener diode with maximum sink current 50µA. Therefore, to raise the CS pin voltage to 8.5V or more, 50µA or a higher current needs to be supplied from the optocoupler. Set the current input to the CS pin to 1mA or less.

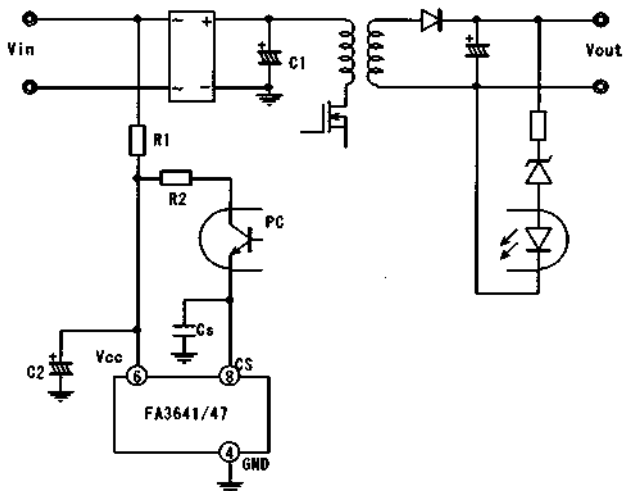

Fig.25 Overvoltage shutdown circuit (1)

(ii) Detecting on primary side (detecting Vcc voltage)

To attain overvoltage protection, the CS pin voltage is forcibly raised from outside the IC until it exceeds the reference voltage (8.5V) of the internal comparator C2. When the reference voltage is exceeded, the IC enters latch mode and shuts the output down. Connect a zener diode (ZD) and resistor between the Vcc and CS pins as shown in Figure 26. When the Vcc voltage exceeds about ZD voltage + 8.5V, the IC enters the OFF latch mode and shuts the output down. If Vcc remains high even after shutdown and current is input to the CS pin, set the current to 1mA or lower.

Set the zener voltage of the ZD connected to the CS pin higher than the UVLO ON threshold voltage. Startup is disabled below this voltage.

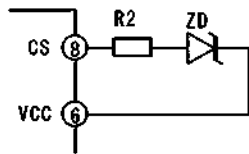

Fig.26 Overvoltage shutdown circuit (2)

Figure 27 shows another circuit for enabling latch mode shutdown by detecting a desired Vcc voltage using the CS pin. In this circuit, overvoltage shutdown works when the Vcc voltage is about the same as the ZD voltage.

For this circuit also, use a ZD voltage higher than the UVLO ON threshold voltage. Set the current flowing into the CS pin to 1mA or lower.

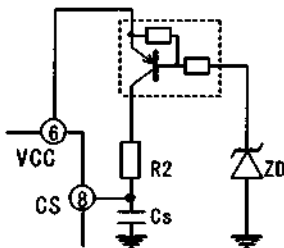

Fig.27 Overvoltage shutdown circuit (3)

(8) Feedback pin circuit

Figure 28 gives an example of connection in which a feedback signal is input to the FB pin.

If this circuit causes power supply instability, connect R3 and C4 as shown in Figure 28 to decrease the frequency gain. Set R3 between several tens of ohms to several kilohms and C4 between several thousand picofarads to one microfarad. Be especially careful in light load mode, in which the frequency drops, thereby increasing the probability of power supply instability being triggered.

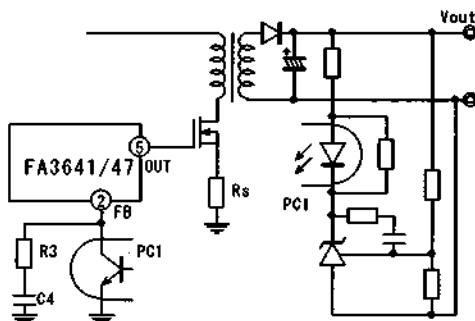

Fig.28 FB pin circuit

(9) REF characteristics

If noise is applied to the VCC pin from the outside, it may appear at the REF pin without attenuation depending on the noise frequency. The noise causes no problems in normal IC operation, but must be taken into consideration when the REF voltage is used for an external circuit. If the noise appearing at the REF pin causes any problems, use the REF pin as shown in Figure 29.

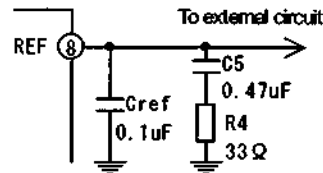

Fig.29 REF pin circuit

(10) Simple voltage control on the primary side

In a flyback type power supply, the output voltages of the power supply and auxiliary winding voltage are almost proportional to the number of winding turns of the transformer. This characteristic can be used in the circuit shown in Figure 30, where the output voltage can easily be made constant by detecting the voltage of the auxiliary winding.

However, this is an easy output voltage control method, and the output voltage precision and regulation are therefore not as good. To reduce output pulse width completely to 0%, the FB pin voltage must fall below 0.95V and R5 must be set below about 960 Ohms from the characteristics of the FB pin source current. When using this method, also keep in mind the characteristics of REF in (8).

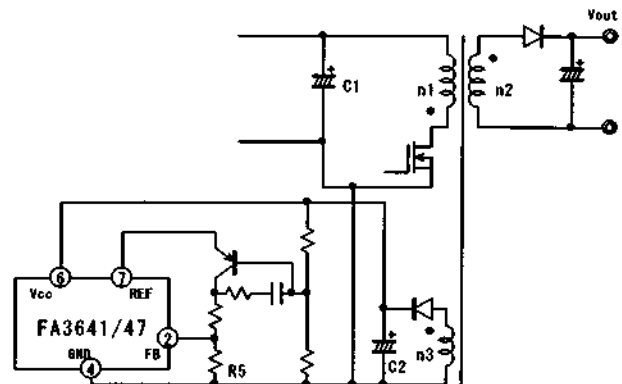

Fig.30 Simple voltage control circuit

(11) Disabling the overload shutdown function

As shown in Figure 31, connect an 8.2k Ohm resistor R6 between the FB pin and the ground. The FB pin voltage then does not rise sufficiently high to reach the shutdown threshold voltage when an overload occurs so that IC does not enter OFF latch mode. Even with this connection, the overvoltage shutdown function is available.

Since resistor R6 limits the upper voltage of the FB pin, the maximum duty cycle may be limited to about 65%, if a 5% precision resistor is used. To not limit the maximum duty cycle, use a 2% or better-precision resistor for R6.

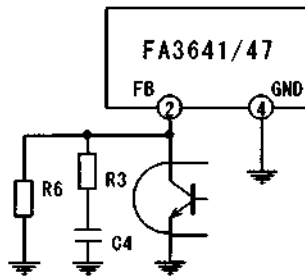

Fig.31 Disabling overload shutdown function

(12) Polarities for overcurrent detecting and their characteristics

The FA3641 uses positive polarity detection for overcurrent limiting (number 3 pin of IS terminal) and the FA3647 uses negative polarity detection. The characteristics of positive and negative polarity detection are summarized below. Select one in accordance with the circuit used. (See item (5) in Section 8, "Description of each circuit.")

Positive detection (FA3641)	<ul style="list-style-type: none"> - Wiring is easy because the ground can be shared by the main circuit and IC peripherals. - It is easy to correct the overload detecting current, which is used to detect overload, against the input voltage.
Negative detection (FA3647)	<ul style="list-style-type: none"> - The MOSFET drive current does not flow to the current detection resistor and therefore it hardly affects overcurrent detection.

(13) Correcting overload detection current (FA3641 only)

If the power supply output is overload, the IC overcurrent limiting function restricts the output power and the overload shutdown function stops the IC. The output current when an overload occurs varies depending on the input voltage; the higher the input voltage, the more the overload detection current may increase.

If any problems occur as a result of the appearance of this symptom, connect resistor R8 between current detection resistor R_s and the IS (+) terminal and add resistor R7 for correction as shown in Figure 32. The standard resistance of R8 is several hundred ohms and that of R7 is from several hundred kilohms to several megohms.

Note that the above correction slightly lowers the output current when overload even where the input voltage is low. This correction is available only for the FA3641 IC that uses positive polarity for overcurrent detection.

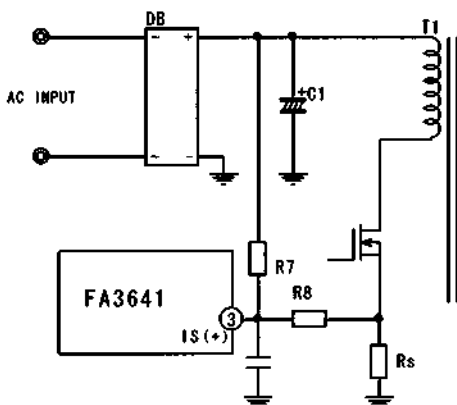

Fig.32 Correcting overload detecting current circuit

(14) Preventing malfunction caused by noise

The IS pin for overcurrent limiting function detects the MOSFET current converted to the voltage. The parasitic capacitor and inductor of the MOSFET, transformer, wiring, etc. cause a noise in switching operation. If this switching noise causes a malfunction of overcurrent limiting function, insert the RC filter into IS pin as shown in Figure 14. Also, connect a noise prevention capacitor (0.1 μ F or more) to the REF pin that outputs the reference voltage for each component.

(15) Preventing malfunction caused by negative voltage applied to a pin

When large negative voltage is applied to each IC pin, a parasitic element in the IC may operate and cause malfunction. Be careful not to allow the voltage applied to each pin to drop below -0.3V.

Especially for the OUT pin, voltage oscillation caused after the MOSFET turns off may be applied to the OUT pin via the parasitic capacitance of the MOSFET, causing the negative voltage to be applied to the OUT pin. If the voltage falls below -0.3V, add a Schottky diode between the OUT pin and the ground. The forward voltage of the Schottky diode can suppress the voltage applied to the OUT pin.

Use the low forward voltage of the Schottky diode. Similarly, be careful not to allow the voltages at other pin drop below -0.3V.

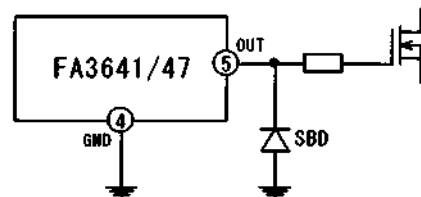

Fig.33 Protection of OUT pin against the negative voltage

(16) Gate circuit configuration

To adjust switching speeds or prevent oscillation at gate terminals, resistors are normally inserted between the power MOSFET gate terminal to be driven and the OUT pin of the IC. You may prefer to decide on the drive current independently, to turn the MOSFET on and off. If so, connect the MOSFET gate terminal to the OUT pin of the IC as shown in Figure 34.

In the circuit shown in Figure 34, Rg1 and Rg2 restrict the current when the MOSFET is turned on, and only Rg1 restricts the current when it is turned off.

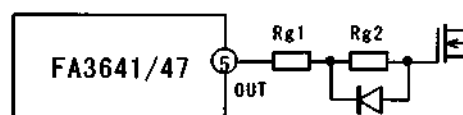

Fig.34 Gate circuit

(18) Loss calculation

IC loss must be confirmed to use the IC within the ratings. Since it is hard to directly measure IC loss, some examples of calculating approximate IC loss are given below.

(i) Calculation example 1

Suppose the supply voltage is V_{cc} , IC current consumption is I_{ccop} , the total gate charge of the power MOSFET is Q_g , and the switching frequency is f_{sw} . Total IC loss P_d can be calculated by:

$$P_d = V_{cc} \times (I_{ccop} + Q_g \times f_{sw}) \dots\dots (14)$$

This expression calculates an approximate value of P_d , which is normally a little larger than the actual loss. Since various conditions such as temperature characteristics apply, thoroughly verify the appropriateness of the calculation under all applicable conditions.

Example:

When $V_{cc} = 18V$, $I_{ccop} = 2.5mA$ (max.) is obtained from the specifications. Suppose $Q_g = 80nC$ and $f_{sw} = 100kHz$.

$$P_d = 18V \times (2.5mA + 80nC \times 100kHz) \\ = 189mW$$

(ii) Calculation example 2

The IC loss consists of the loss caused by operation of the control circuit and the loss caused at the output circuit to drive the power MOSFET.

1) Loss at the control circuit

The loss caused by operation of the IC control circuit is calculated by the supply voltage and IC current consumption. When the supply voltage is V_{cc} and IC current consumption is I_{ccop} , loss P_{op} at the control circuit is:

$$P_{op} = V_{cc} \times I_{ccop} \dots\dots\dots (15)$$

Example:

When $V_{cc} = 18V$, $I_{ccop} = 1.9mA$ (typ.) is obtained from the specifications. The typical IC loss is given by:

$$P_{op} = 18V \times 1.9mA = 34.2mW$$

2) Loss at the output circuit

The output circuit of the IC is a MOSFET push-pull circuit. When the ON resistances of MOSFETs making up the output circuit are R_{on} and R_{off} , the resistances can be determined as shown below based on $V_{cc} = 18V$ and $T_j = 25^\circ C$ obtained from the output characteristics included in the specifications:

$$R_{on} = 15\Omega \text{ (typ)}$$

$$R_{off} = 7\Omega \text{ (typ)}$$

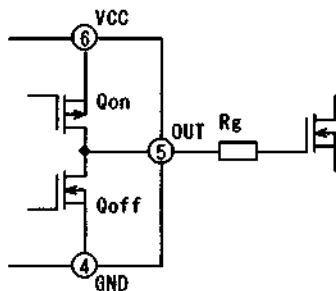

Fig.35 Output stage

When the total gate charge of the power MOSFET is Q_g , the switching frequency is f_{sw} , the supply voltage is V_{cc} , and gate resistance is R_g , the loss caused at the IC output circuit is given by:

$$P_{dr} = \frac{1}{2} \times V_{cc} \times Q_g \times f_{sw} \times \left(\frac{R_{on}}{R_g + R_{on}} + \frac{R_{off}}{R_g + R_{off}} \right) \dots\dots (16)$$

When gate resistance differs between ON and OFF as shown in Figure 36, the loss is given by:

$$P_{dr} = \frac{1}{2} \times V_{cc} \times Q_g \times f_{sw} \times \left(\frac{R_{on}}{R_{g1} + R_{g2} + R_{on}} + \frac{R_{off}}{R_{g1} + R_{off}} \right) \dots (17)$$

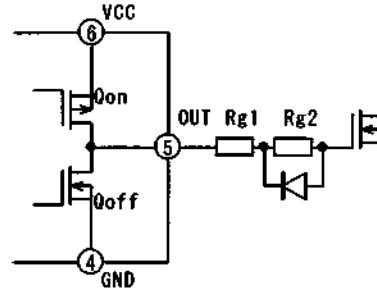

Fig.36 Gate circuit

Example:

When $V_{cc} = 18V$, $Q_g = 80 nC$, $f_{sw} = 100 kHz$, and $R_g = 10 \Omega$, the typical IC loss is given by:

$$P_{dr} = \frac{1}{2} \times 18V \times 80nC \times 100kHz \times \left(\frac{15\Omega}{10\Omega + 15\Omega} + \frac{7\Omega}{10\Omega + 7\Omega} \right) \\ = 72.8mW$$

3) Total loss

The total loss (P_d) of the IC is the sum of the control circuit loss (P_{op}) and the output circuit loss (P_{dr}) calculated previously:

$$P_d = P_{op} + P_{dr} \dots\dots\dots (18)$$

Example:

The standard IC loss under the conditions used in 1) and 2) above are:

$$P_d = P_{op} + P_{dr} = 34.2mW + 72.8mW = 107mW$$

10. Application circuit

FA3641

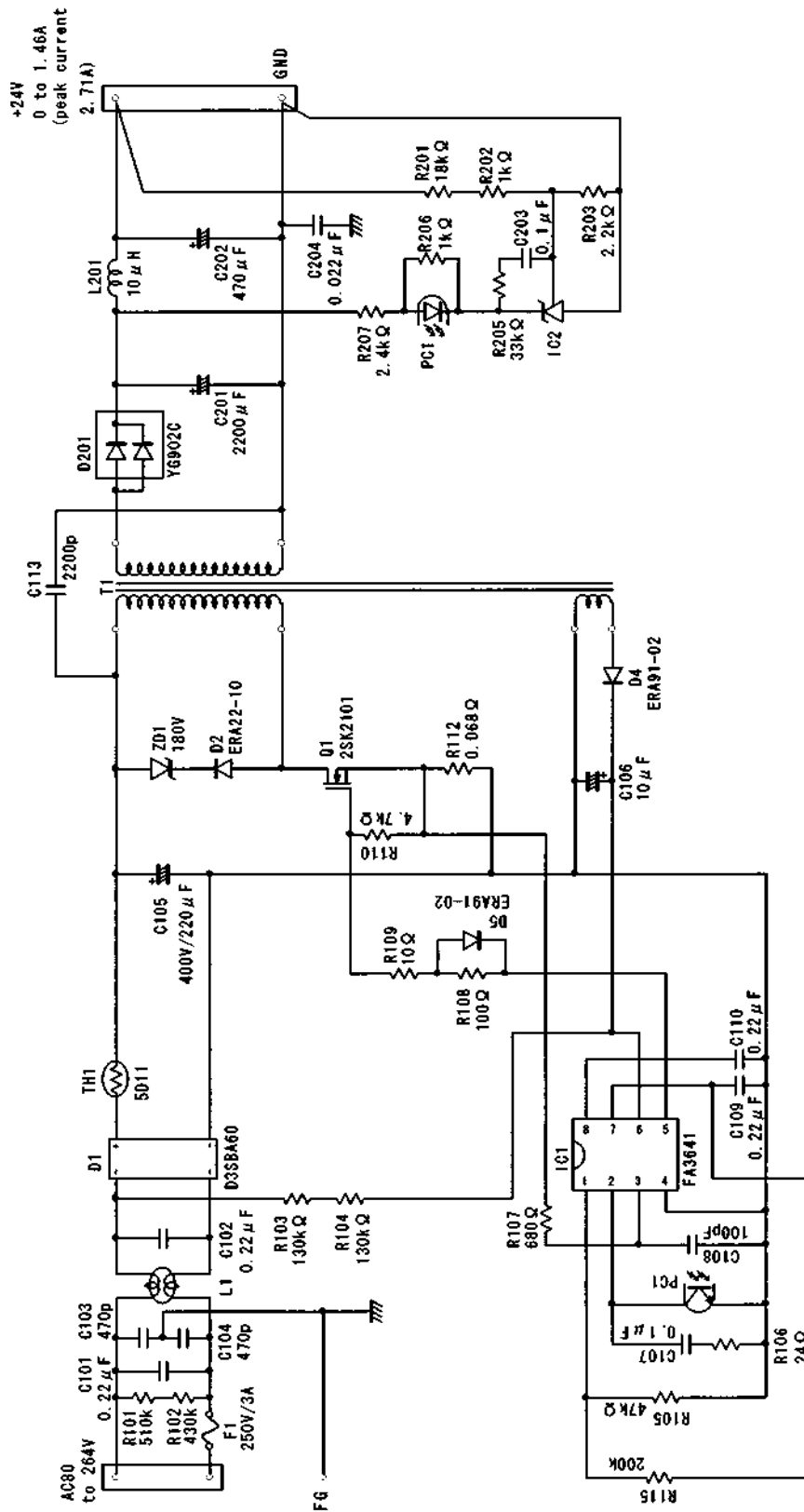

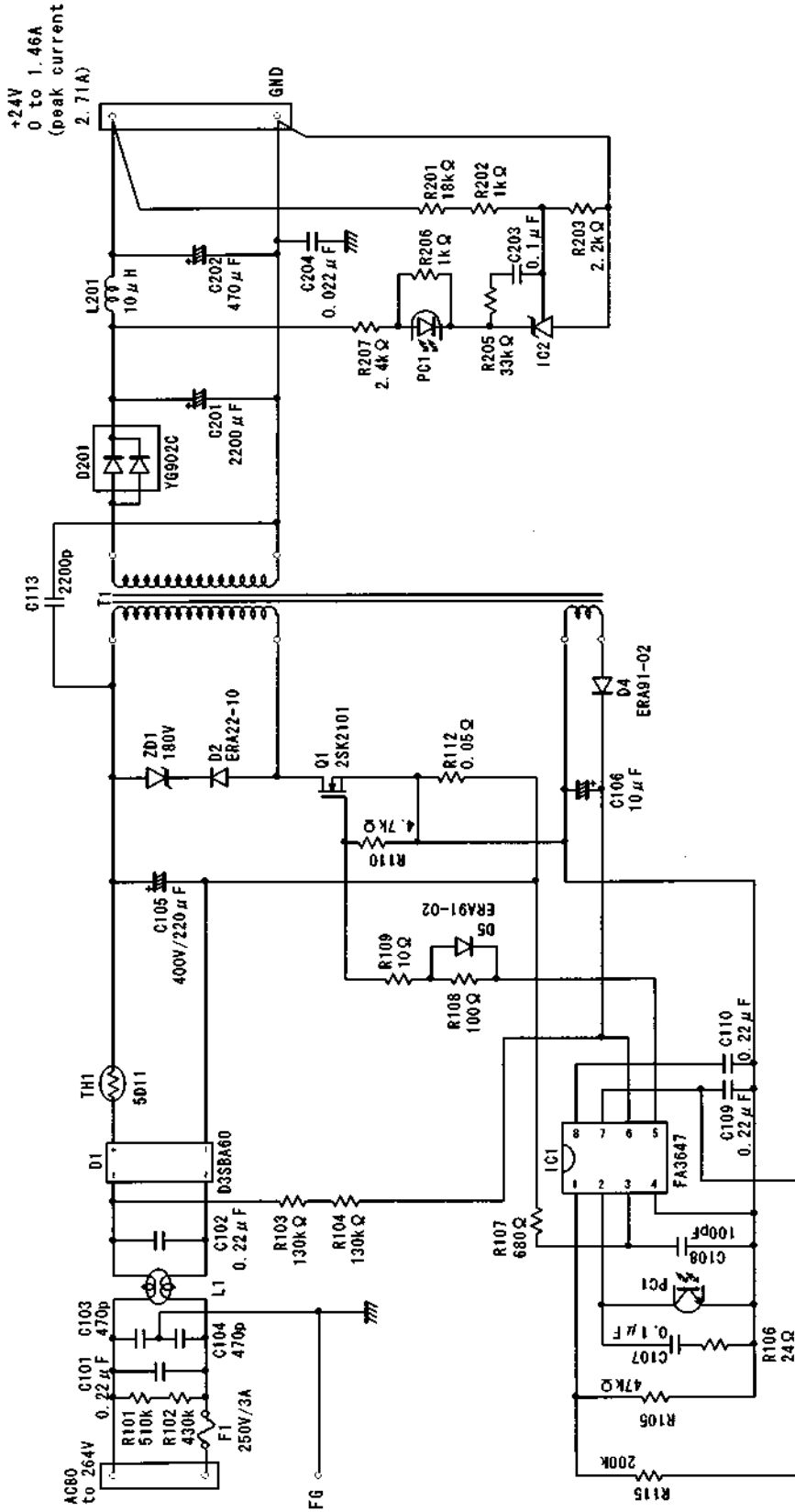

Electrical characteristics of Application circuit (on page 22 and 23)

