

SMD Crystal Resonators / MHz Band Crystal Resonators

DSX211A/DSX211AL

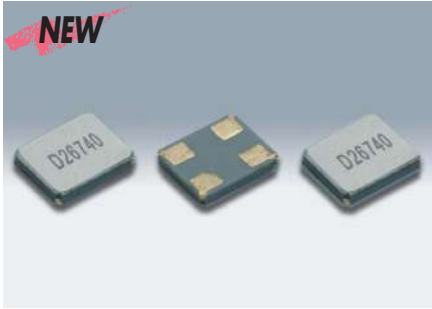

Actual size

■ Features

- 2016 size miniature and lightweight SMD crystal resonator (high DSX211A 0.45mm/DSX211AL 0.35mm)
- High precision and high reliability
- Offers a wide frequency range from a comparatively low 24MHz up to 50MHz.

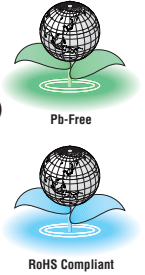

■ Applications

- Telecommunications products like short-range wireless modules and other small devices such as DVC, DSC, PDA, PC.

■ Standard Specification

Item	Type	DSX211A	
		DSX211AL	
Frequency Range		24~26MHz	26~36MHz
Overtone Order		Fundamental	
Load Capacitance		Series, 8pF, 10pF, 12pF	
Drive Level		10μW (100μW max.)	
Frequency Tolerance		±10×10 ⁻⁶ , ±20×10 ⁻⁶ , ±30×10 ⁻⁶ , ±50×10 ⁻⁶ (at 25°C)	
Series Resistance		100Ω max.	60Ω max.
Frequency Characteristics over Temperature		±8×10 ⁻⁶ / -10~+60°C (Ref. to 25°C)	
		±12×10 ⁻⁶ / -20~+70°C (Ref. to 25°C)	
		±15×10 ⁻⁶ / -30~+85°C (Ref. to 25°C)	
Storage Temperature Range		-40~+85°C	
Packing Unit		3000pcs./reel (φ180)	

Consult our sales representative for other specifications.

■ Dimensions [mm]

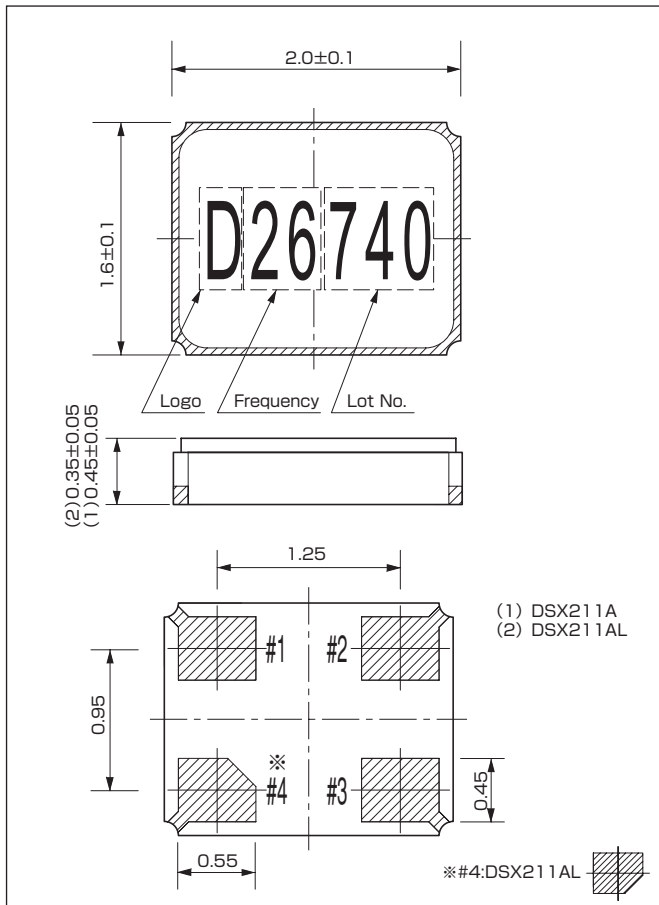

■ Internal Connections

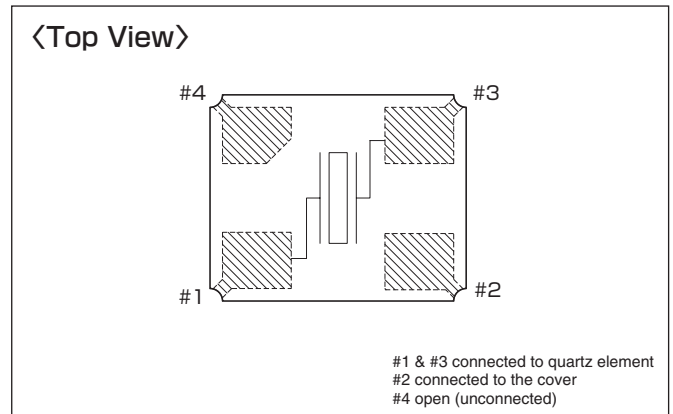

■ Recommended Land Pattern

[mm]

