

SPECIFICATION

FOR APPRONAL

Customer : _____

Product Name : Piezo Buzzer(Self-drive) _____

Model Name : VSI292412F35 _____

Drawing No. : VS20200909015 _____

Signature of Voise

Approved by	Checkde by	Issued by	Date

Voise 福爱斯电子有限公司
ELECTRONIC VOISE ELECTRONICS CO.,LTD.

Office Add:Haoyangguang B-302# No.968 Baizhang Road,Ningbo China
Factory add: Shishan Industrial Park Moushan Town Yuyao City China
Tel:86-0574-87471601 Fax:86-0574-87471603 P.C.315000
Http://www.nbvoise.com E-mail:sales@nbvoise.com

Specification for Piezo Buzzer		Page	2/6
		Revision No.	1.0
Model No.:	VSI292412F35	Drawing No.	VS20200909015

Table of contents

- 1. Revision
- 2. Scope
- 3. General Characteristics
- 4. Electrical and Acoustic Characteristics.
- 5. Reliability Test
- 6. Dimensions
- 7. Packing

1. Revision

Rev.No.	Date	Page	Description of Revision
1.0	2020/9/9		Preliminary

Specification for Piezo Buzzer		Page	3/6	
		Revision No.	1.0	
Model No.:	VSI292412F35		Drawing No.	VS20200909015

2. Scope

This product specification is applied to the Piezo Buzzer in alarm systems. Please contact us when using this product for any other applications than described in the above.

3. General Characteristics

- 3.1 Out-Diameter : 29.5 mm
- 3.2 Height : 24.5 mm
- 3.3 Weight : 17 g
- 3.4 Operating Temperature : -20~+60°C without loss of function
- 3.5 Store Temperature : -30~+70°C without loss of function

4. Electrical and Acoustic Characteristics.

Test condition : 15 ~ 35 °C Temp., 25% ~ 75% RH, 86~106 kPa Refer to IEC60268-1

No	Items	Specification
1	Rated Voltage	12V DC
2	Working Voltage	3-24V DC
3	Max Rated Current	15mA/12VDC
4	Min Sound Pressure Level	90dB/12VDC/30cm;
5	Resonant Frequency	3.5±0.5KHz
6	Tone Nature	1 Tone +Fast Pulse
7	Housing Material	ABS
8	Color	Black

Specification for Piezo Buzzer		Page	4/6
		Revision No.	1.0
Model No.:	VSI292412F35	Drawing No.	VS20200909015

5. Reliability Test

After test(1~7item), the buzzer S.P.L . difference shall be within $\pm 8\text{dB}$, and the appearance not exist any change to be harmful to normal operation

No	Items	Specification
1	High Temp.Test	After being woked in a chamber with $+70\pm 2\text{ }^\circ\text{C}$ for 2h and then being placed in natural condition for 2h, and then check.
2	Low Temp.Test	First being worked in a chamber with $-20\pm 2\text{ }^\circ\text{C}$ for 2h and then being placed in natural condtion for 2h, and then check.
3	Humidity Test	After being placed in a chamber with 90 to 95%R.H. at $+40\pm 2\text{ }^\circ\text{C}$ for 2 h and then being placed in natural condition for 2h ,and then check.
4	Thermal Shock Test	After being worked in a chamber at $+70\pm 2\text{ }^\circ\text{C}$ for 1 hour, then sounder shall be placed in a chamber at $-20\pm 2\text{ }^\circ\text{C}$ for 1 hour(1 cycle is the below diagram). The test duration is for 10 cycle.after being placed in natural condition for 1 hour.and then check.
5	Vibration Test	Being applied vibration of amplitude of 1.5mm with 10-30Hz band of vibration frequency,X.Y.Z.3 direction.2 hours each, total 6 hours.
6	Drop Test	Free drop fram 1.0 meter height to a board 20mm thick hard wood board. and be nothing mechanical damage. tatol 6 times.
7	Solderability	Lead terminals are immersed in rosin for 5 seconds and then immersed in solder bath of $+260\pm 5\text{ }^\circ\text{C}$ for 3 ± 0.5 seconds.
8	Terminal Strength Pulling	The force 10 seconds of 9.8N is applied go each terminal in axial direction.

Specification for Piezo Buzzer		Page	5/6
		Revision No.	1.0
Model No.:	VSI292412F35	Drawing No.	VS20200909015

6. Dimensions

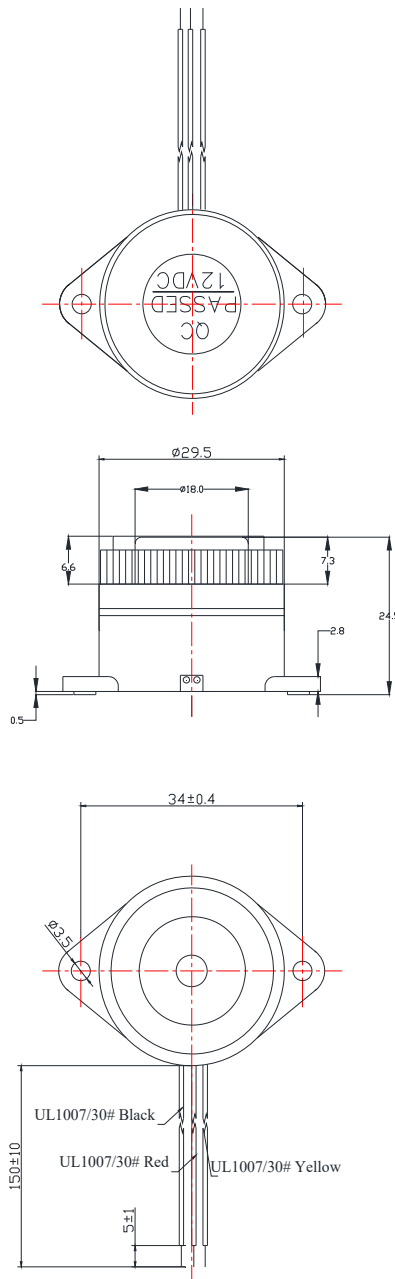

FIRST ANGLE PROJECTION

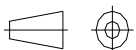

UNIT : mm

Tolerance : ± 0.2

Specification for Piezo Buzzer		Page	6/6
		Revision No.	1.0
Model No.:	VSI292412F35	Drawing No.	VS20200909015

7. Packing

100 pcs per tray
5 trays for unit, 12 units per carton
Total:6000 pcs per carton
Size:520x420x280mm